

# CHALMERS

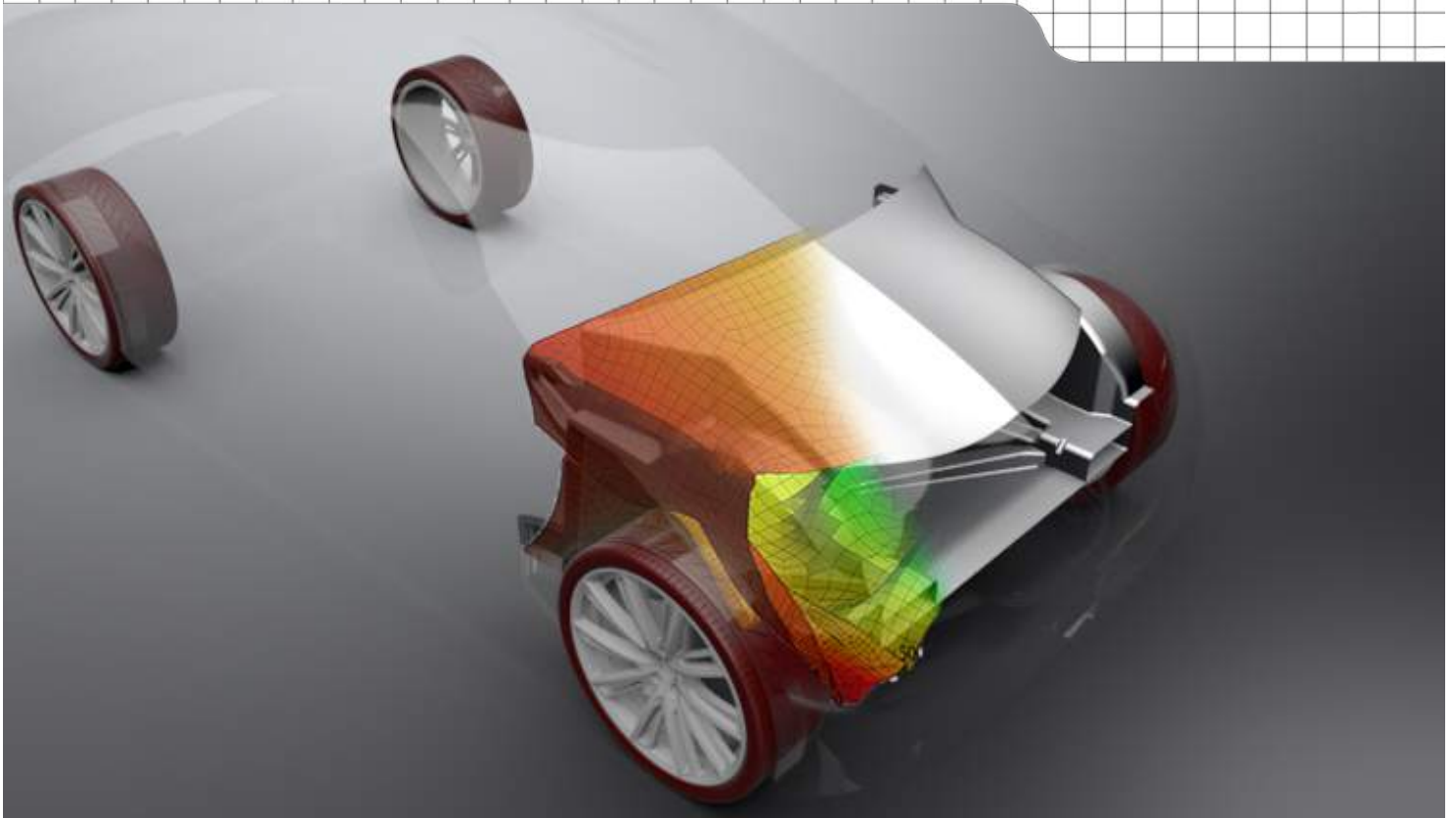

## Body in white architecture for an electric vehicle concept

Master of Science Thesis in the Master Degree Program, Industrial Design Engineering

JOSUE ENRIQUEZ





Master of Science Thesis PPUX05

**Body in white architecture for an electric vehicle concept**

Master of Science Thesis in the Master Degree Program, Industrial Design Engineering

© Josue Enriquez

Chalmers University of Technology  
SE-412 96 Goteborg, Sweden  
Telefon +46(0) 31-772 1000

Cover photo: Josue Enriquez  
Print: Repro Service Chalmers





# ABSTRACT

Electric vehicles have developed largely in recent years, exhibiting continuous improvements on battery power and propulsion system. It is expected that other components of the EV system develop parallel. However it has not been the case for body-in-white which have not yet taken the leap from the classical combustion architecture to a more suitable EV structure.

The thesis addresses the design of the structure architecture from the Crashworthiness point of view, as this is a driving force for car manufacturing in Sweden. Different high speed crash tests were analysed in order to adapt the load paths for better efficiency, the general aspects of those cases were modelled using finite element analysis for a better understanding of the structure behaviour. Based on the results, different geometry changes in the architecture were evaluated.

The result is a design proposal for the body-in-white that meets EV specific requirements. This sets an structural base that allows the designer to explore new possibilities of packaging and functionality. The proposed architecture permits the arrangement of some elements that interact directly with the structure, such as cabin room, battery size and cooling package.

The outcome of the thesis is an electric vehicle concept that shows the changes and advantages that can be achieved when designing an EV based on crashworthiness criteria.

Keywords: Body in white, crashworthiness, electric vehicle concept.

# AKNOWLEDGMENTS

This thesis has been developed with the great help of Erik Westerlund and Pontus Wallgren. Who have put their time and effort in guiding and correcting the design process.



# INDEX

ABSTRACT	1
AKNOWLEDGMENTS	2
INDEX	3
GLOSSARY	5
1. INTRODUCTION	7
1.1 FRONTAL STRUCTURE ARCHITECTURE FOR AN ELECTRIC VEHICLE CONCEPT	8
1.1.1 Aim	8
1.1.2 Goal	8
1.1.3 Scope	8
1.1.4 Objectives	9
1.1.5 Limitations	9
1.1.6 Expected results	9
1.1.7 Research questions	9
1.2 RESEARCH AND IDEA GENERATION METHODS	10
1.2.1 Literature study	10
1.2.2 Car base study	10
1.2.3 Body-in-white requirements	10
1.2.4 Structural criteria	10
1.2.5 Crashworthiness criteria	11
1.2.6 Observation of current electric car body	11
1.2.7 Visit at the Volvo Body-in-white department	11
1.2.8 Benchmarking	11
1.2.9 Interviews	11
1.2.10 KJ Diagrams method	11
1.2.11 Gate decision matrix	12
1.2.12 Macey's car design process	12
1.2.13 Survey user study for perception requirements	12
1.2.14 Segment selection	12
1.2.14 Ergonomic criteria	13
1.2.15 Design format analysis	13
1.2.16 User study of car features	13
1.2.17 Target group	13
1.2.18 Positioning the concept in context	13
2. BACKGROUND CONCEPT	14
2.1 BACKGROUND RESEARCH AND ANALYSIS	15
2.1.1 Car identity	15
2.1.2 Electric car evolution	15
2.1.3 Car base	16
2.1.4 Dimensions	17
2.1.5 Wheelbase and A-Pillar	17
2.1.6 Enter CG position and height	17
2.1.7 Body-in-white	19
2.1.8 Benchmark	19
2.1.9 Moderate overlap crash test	19
2.1.10 Full Width Rigid Barrier	20

2.1.11 Small overlap frontal test	20
2.1.12 Fork case	21
2.1.13 Front pole crash	21
2.1.14 Vehicle incompatibility	22
<b>2.2 ANALYSIS</b>	<b>23</b>
2.2.1 Small overlap analysis	23
2.2.2 Moderate overlap analysis	25
2.2.3 Openings and access to components	27
2.2.4 Frontal storage space	28
2.2.6 Functional model	29
2.2.7 Solution model	30
2.2.8 Interview analysis	31
<b>3. CONCEPT DEVELOPMENT</b>	<b>32</b>
<b>CONCEPT DEVELOPMENT AND DESIGN THINKING</b>	<b>33</b>
3.1 Unity of the concept	33
3.1 Solutions for small overlap	33
3.2 Solutions for moderate overlap and fork case	36
3.3 Firewall	38
3.4 Batteries	39
3.5 Hood	42
3.6 Closed structure	42
3.7 Tire envelope and suspension	43
3.8 Cooling	43
3.9 Ergonomics	45
3.10 Segment	47
3.11 Brand identity	49
3.12 Expression board	50
3.13 Synergy process and filtering	51
<b>4. CONCEPT</b>	<b>52</b>
<b>FINAL CONCEPT</b>	<b>53</b>
4.1 Body in White	54
4.3 Connecting sidemembers	54
4.4 Angled crossmember	55
4.5 Air cooling for battery	56
4.6 Battery brackets with pyro nuts	57
4.7 Accesibility	58
4.8 Body work and design	58
4.9 A note on aerodynamics	59
<b>5. CONCLUSIONS</b>	<b>60</b>
5.1 Sustainability	61
5.2 Discussion	62
5.3 Conclusion	63
5.4 RECOMENDATIONS	63
REFERENCES	64
Figures references	66
APPENDIX	67

# GLOSSARY

The terms used in this report correspond to abbreviations of mentioned organizations, car industry common terms and specific parts of the body in white architecture.

## Abbreviations of organisations

**EuroNCAP** – European New Car Assessment Programme

**IIHS** – Insurance Institute for Highway safety

**NHTSA** – National Highway Traffic Safety Administration

## Car industry common terms

**Axis** – Lines about a mechanism, assembly or wheel rotates

**Body-in-White (BIW)** – Unpainted car body assembly, metal parts welded and rivets fastened, but not trim or components assembled.

**Cross members** – Beams running in the transverse direction that stiffen the structure

**Curb Weight** – The total mass of the vehicle adding all the components and fluids, but no passengers or cargo.

**Crumple zone** – Portion of the vehicle designated to absorb the energy generated in an impact controlled by deformation.

**Firewall** – The element separating the passenger cabin and the engine compartment heat and fluids.

**Gross Vehicle Weight (GVW)** – The weight of the vehicle loaded at maximum capacity.

**H-Point** – The hip point that reference to the seating position on the vehicle.

**Monocoque** – Refers to an integral structure made from metal panels, joined by spot welding or riveting, stiff enough to not need a separate chassis.

**Origin point** – Theoretical point which is the absolute zero of every axis in a three dimensional space.

**Overhang** – Longitudinal portion of the body-in-white starting from the axis point to the foremost surface of the front of the car.

**Packaging** – Used space, organization and localization in reference to the origin point of every component driven by function inside and outside of the vehicle.

**Powertrain** – The drive system that generates power and initiates movement in the vehicle.

**Scalable Product Architecture (SPA)** – It's the platform that Volvo cars use for their vehicles since 2014.

**Side rail** – Beams running in the longitudinal direction and support the engine.

**Sill** – Side members running in the longitudinal direction starting in the lower A-Pillar alongside the vehicle to the C-Pillar. Constitute the structure under the car stiffening the floor.

**Tire envelope** – The volume required from the tire for steering, rotating and travel by the steering and the suspension system.

**Wheel axle** – Imaginary line that points the centre of the front wheels in relation to the origin point.

**Wheelbase** – Distance between the centre of the front wheel axle and the rear wheel axle.

## Crashworthiness terms

**Frontal crash test** – Full frontal impact into a rigid barrier at 35Mph

**Small overlap test** – Test released by the IIHS in 2012, where a vehicle is impacted at 25% of the front end at 40Mph.

**Bumper test** – Impacts at 3Mph in the longitudinal direction.

## Body in white parts

Most frequent terms are regarding the frontal components of the body in white.

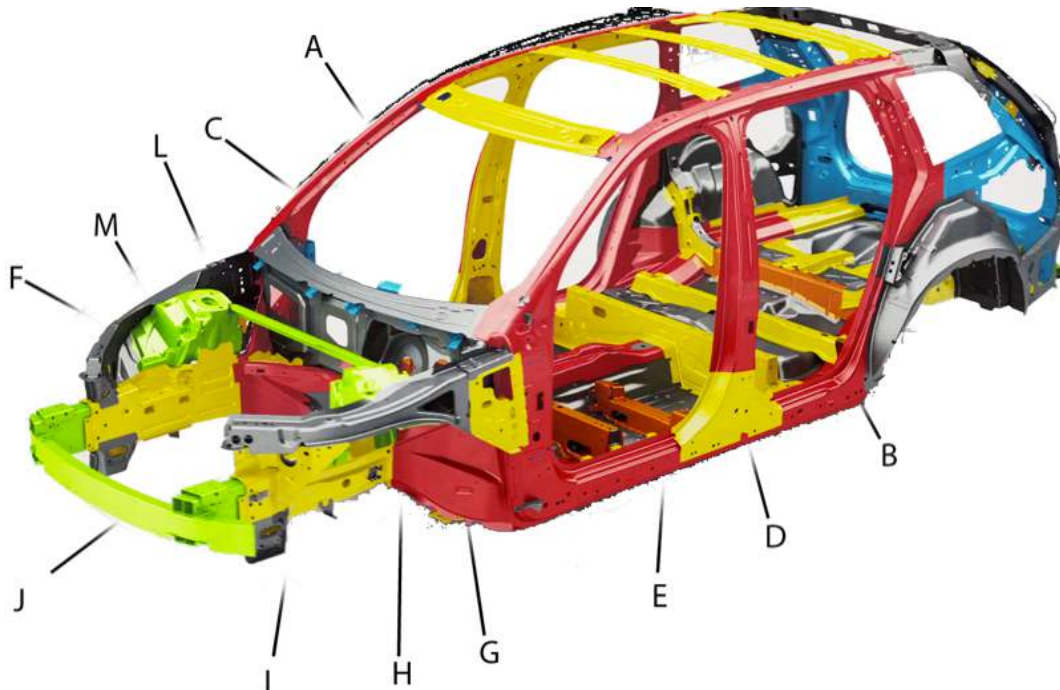

*Figure 1. Body-in-white components*

- A. Upper A-Pillar
- B. B-Pillar
- C. Cowl
- D. Sill
- E. Floor
- F. Longitudinal side rail or Side member
- G. Wheel house
- H. Upper wing member, Motor compartment upper rail or shotgun
- I. Crash box
- J. Bumper
- K. Firewall
- L. Suspension tower
- M. Inner wing panel or motor compartment side panel
- N. Centre longitudinal tunnel or Tunnel

# 1. INTRODUCTION

This chapter defines the background of the research and set the framework for the thesis development.

# 1.1 FRONTAL STRUCTURE ARCHITECTURE FOR AN ELECTRIC VEHICLE CONCEPT

---

## BACKGROUND

Electric cars are developing fast and the market is growing at the same speed. With new competitors on the mobility scenario as Tesla Cars, other rather traditional car manufacturers start to walk in the electric development direction in a more serious manner. The development of the new generation of transportation faces several challenges, from technological to logistical. Substantial advances have been reached on the powertrain technology for electric cars and this has led to better efficiency on the energy use and better mileage. However, other parts of the vehicle have not received the same attention. The practicality of using a standard monocoque body is evident. However, the packaging requirements of an electric car are different because under the hoop, where there was the combustion engine, now there is an empty space used as baggage storage. Then the classic architecture for the front structure might be over dimensioned for such use. This situation could be analysed to improve the outcome of the electric car design process.

### 1.1.1 Aim

Outline a design proposal for the body in white front structure and the surface bodywork for an electric concept car.

### 1.1.2 Goal

Design a proposal for the frontal structure in white body for an electric concept car based on the requirements of crashworthiness for frontal and small overlap crash tests. The structural architecture would set the boundaries for to design a proposal of bodywork following design cues that reflect the identity of a selected brand.

### 1.1.3 Scope

The present project concentrates on the idea generation around the possibilities that are presented in a frontal structure body in white of an electrical car.

The concept will be based on a real platform used in the current market in order to bring the project close to the reality in structure dimensions and boundaries.

Focus will be on the crashworthiness of the car limited by the requirements for two crash scenarios, using as input load cases of the frontal impact and small overlap impact.

Some internal components will be addressed if those are directly related or have some major influence on the structure design.

Packaging of most mechanical and electronic components will not be addressed, even when it is one of the most important aspects for an electrical car. Assuming that the space provided in the structure would allow the flexibility to accommodate different elements and that those

elements have small dimensions and can be moved around the car structure with ease.

The final result is a well developed concept product, with a solid base on crashworthiness and packaging. No real test would be performed, but computer simulations on the structure and energy absorption will be presented to validate the proposal.

### 1.1.4 Objectives

- Study the current concept of body in white structure of a standard combustion car model out in the market. Then benchmark the general dimensions and structure with a comparable electric car out in the market.
- Benchmark the structure stiffness of a combustion car and an electrical car in order to gather information for the proposal.
- Survey the needs for electric cars front packaging and the most common use of storage spaces. Survey the common perception of electric cars and the most important characteristics that define a car segment.
- Use design methods to generate and evaluate ideas that could be implemented in the structure of an electric car in real life situations.
- The work will include the analysis of the body in white frontal structure, the packaging of components and the concept for aerodynamic exterior.

### 1.1.5 Limitations

The car monocoque is a very complex structure developed by a team of many engineers in big manufacturing companies and is carried by a long time process. The task of redesigning an entire proposal for a front structure would be very extensive by considering all the aspects that

will interact with each other, manufacturing planning and safety considerations. As this project does not only focus on the structure of the body in white, but also on the external body work and moreover on the idea generation for a concept for electric car frontal packaging, such approach of project is not considered.

### 1.1.6 Expected results

The thesis should provide a 3D design modelled in Catia with detailed drawings of the components, as well as an assembly with all the elements of the structure and body work.

Computer analysis of the stiffness of the front structure of the body in white using finite element method to approach a converged solution.

Design of the bodywork that flows with the design of the car creating unity in the proposal and aspect.

### 1.1.7 Research questions

The evolution of the cars is a slow process. Long time ago, since car appeared, not many changes in the design were made from the horse carriage when the combustion engine was adopted. Now days the electric powertrain is gaining a share in the market but cars remain on the design of the combustion engine even when they use a different technology.

- What would happen to the future of electric car design if the development of the structural architecture is planned from start?
- What are the requirements of an electric car body work?
- How the impacts affect the structure when there is no engine?
- Are there any packaging advantages by designing the frontal structure with the electrical vehicle perspective in mind?

# 1.2 RESEARCH AND IDEA GENERATION METHODS

---

The project is divided in the development of two big concepts. On one hand is the body-in-white frontal structure architecture, which is the focus of the research and the base for the bodywork of the car design. The second refers to the exterior body design of the vehicle, where the style and brand identity play an important role. Those concepts have very different requirements to be addressed, one is entirely structural and the second is perceptive and user directional. At the same time both interact and shape each other setting boundaries and creating design limitations.

This chapter presents the description of the methods used in order to gather information and set the requirements for the concept development.

## BODY-IN-WHITE ARCHITECTURE

### 1.2.1 Literature study

The pre-study of the subject is intended to provide the basic concepts in order to understand how the system works and what the basic requirements of the vehicle are. This understanding is acquired by reading different printed material in order to understand the extension of the project. The related literature will be the base to set important variables that have to be considered for synthesising the technical needs. The materials include books, previous thesis reports, videos, technical reading, published papers, journals, specialised magazines and articles.

### 1.2.2 Car base study

One of the first steps of the process is to set a car base to work on; the car base will provide the overall dimensions, wheelbase, track, initial structure and monocoque to evaluate the current market vehicle on which the design

proposal will be built. Furthermore, setting the car base will also permit to find a suitable benchmarking vehicle from the market pool. Once the two vehicles are set, a comparison in different areas will help to analyse the solutions that the market offers nowadays in relation of electric vehicles.

### 1.2.3 Body-in-white requirements

There are several structural requirements, as well as legal requirements that are to be followed in order to produce a commercial vehicle. By analysing the literature found in the pre-study, this task focuses on the specific stiffness and torsion requirements for the design of the frontal structure, also setting the dimension boundaries of the body-in-white.

### 1.2.4 Structural criteria

The vehicle is subject to three main different cases that determine the requirements for the correct performance of the structure over the road. As the vehicle passes through an uneven path, different loads are generated from the



ground and transmitted to the body to be absorbed and distributed. The structure should be able to withstand those forces at its biggest dimensions, in order to ensure the capabilities of the vehicle at most demanding roads and safety scenarios. The basic load cases that concern the body structure are bending case, torsion case and lateral case.

### **1.2.5 Crashworthiness criteria**

In recent years the crashworthiness attention has increased by governments to make the roads safer, leading to laws and investment into investigation. Those changes have encouraged manufacturers to consider crashworthiness as one of the main points for design and engineering of a new vehicle. In several regions the road vehicles have to fulfil basic safety requirements in order to be legal. Among the many tests conducted, the most relevant for the project are moderate overlap test and small overlap at high speed. It is also considered the bumper test at low speed.

### **1.2.6 Observation of current electric car body**

A visit to the closest dealer in town was done in order to identify the design features of the selected benchmarking electric alternative. At that place it was easy to have a first-hand glimpse to the architecture used in the vehicle, as well as the materials and the packaging distribution.

### **1.2.7 Visit at the Volvo Body-in-white department**

After deciding the car base, it was necessary to draw a closer look to the real product in order to gain a better understanding and knowledge about the construction of the vehicle and process of manufacturing. The visit

permitted a real observation of current and past BIW models, as well as a detailed inspection of design, and construction. Moreover, going through the BIW department brought a first-hand examination of the SPA and the details of the current architecture.

### **1.2.8 Benchmarking**

Macey describes benchmarking as the most empowering packaging tool a designer can use (for car design), because it provides the key to set up proportions and packaging elements with confidence (Macey, 2014). A comparison between two or more vehicles takes the important points that have been previously developed by many companies and engineers, and this sets the project into a real context. This comparison can display fast changes, areas, distribution, space perception, occupant area, packaging location, innovative features and crashworthiness zones. For a packaging benchmarking study the model should portrait the vehicle outline, the tires, wheelbase, front axle point, H-point and curb line, as well as the components that are to be compared.

### **1.2.9 Interviews**

The interview method is one of the best ways to obtain important information about ideas and opinions from experts or users. The obtained data is usually non quantitative as the interviewees usually talk wide spread on concepts. The key factor is the relevance of the answer and not the number. In order to gather as much information as possible the questions setup are open ended, using a semi-structured format in order to obtain some specific information.

### **1.2.10 KJ Diagrams method**

Also known as association method, it was developed by Kawakita Jiro as a system to map and organize disperse information in

relation to a unique common topic. This method is generally used to find solutions to group problems by addressing the issue from different perspectives. The result of the analysis is finding few causal factors that constitute the base of the problem by collecting and arrange facts by affinity or similarity. The method can be used to organize disperse and vast amount of data obtained from an interview (Ulrich, 20013).

### 1.2.11 Gate decision matrix

Once gathered the information the ideas pass through different gates, which will start by assigning a weight to each criteria in the asses to the general objectives of the project. The decision gates matrix is a multi-dimensional option set which can help to make an ordered

decision using scoring for grading criteria alternatives.

### 1.2.12 Macey's car design process

According to Macey, car design is a process (figure 2), that begins and ends focused on the customer. Needs, likes and aspirations are the guidelines that drive the design from start to finalization. Nevertheless, it is the responsibility of the designer to understand the different forces that shape the market, the technology advances and the style for the vehicle. At the same time the needs and likes should be interpreted with logic and intention, reading between the lines, as the customers not always want what they declare.



Figure 2. The car design process. Macey and Wardle, 2014

## BODYWORK

### 1.2.13 Survey user study for perception requirements

The perception of vehicles varies depending on the design, the style, the segment, the drive power and other variables. A car can have strong characteristics of fuel efficiency or strong customization on the trim level. To bear an example, a truck will peak on the size, the cargo capacity, the power and towing capabilities. On the other hand a luxury sedan would peak in handling, NVH, security, style and brand identity. These characteristics constitute the identity of the car and together are the image that the product project to the public.

### 1.2.14 Segment selection

The market is divided in different segments, each with defined characteristics and limitations. By understanding the position that electric vehicles can have in the market it can be inferred many of their features and the general architecture. Moreover the segment allows the designer to focus on certain characteristics that constitute the personality of the car, as well as the price range, target group and more specific requirements like usable space and powertrain. The segments are manly divided in: micro cars, economy cars, luxury cars, sport cars, minivans, SUV, pickup or small trucks, and commercial vans. It is possible to locate almost every car in the

market in one of those categories. (Macey, 2014)

### **1.2.14 Ergonomic criteria**

The car starts and ends with the user in mind, in that sense, the vehicle should be designed around the driver. The occupants dictate directly the volume, shape and aspect of the design. There are several cues to consider about the packaging and the ergonomics of the occupants. Starting with the driver, the most important to be decided is the H-Point which is the hip point that will be used for the Seating Reference Point, the location of this point influences the entire car dimensions. The second consideration is the allocation of manikins that cover the range from the 5th percentile to the 95th percentile of the population. The use of manikins and standard positions on the industry permits a comfortable and healthy scenario for the driver and passengers.

### **1.2.15 Design format analysis**

The method uses the visual and semantic characteristics of a product to identify the core identity that can be perceived and associated among products of the same line or brand. The design format can be used in several dimensions of a product, assessing different physical characteristics of the shape that constitute unique for that object. By analysing more objects on the same product line it can

be set a bundle of characteristic to create a red thread that defines the identity of a brand. (Warrel, 2001)

### **1.2.16 User study of car features**

Cars are developed to attend the needs of the customers; those needs fit in a certain niche that will constitute the user requirements for design. The objectives will be prioritized by understanding what attributes are more important to the car and this will lead to fit the vehicle into a market segment category.

### **1.2.17 Target group**

Dissecting the market in the pieces that are more relevant for the project is essential to create a design that meets the expectations of the user. In order to extract these requirements two different methods will be approached. First read and investigate in forums of electric cars users what is the average buyer. Second, by the results of an anonymous survey analyse the design perception of electric cars and the average use of certain components.

### **1.2.18 Positioning the concept in context**

All vehicles belong to categories and feature certain characteristics. It is important to find a white space in the product portfolio. (Macey, 2014)

## 2. BACKGROUND CONCEPT

This chapter is an approach to the basic concepts behind the BIW in order to get insights on how the structure works

# 2.1 BACKGROUND RESEARCH AND ANALYSIS

## ELECTRIC VEHICLE BASIC CONCEPTS

### 2.1.1 Car identity

The automobile is unarguably the invention that fashioned the previous century and still does to nowadays. No other machine has been able to shape the society in such a deep manner. The influence the cars have is big and can be traced from self-awareness, freedom, social position and even life-realization. Even though all cars are in some way, propelled machines that serve to the common goal of transportation, the many different styles and technologies assign every single model a unique personality, which can match the customer's identity and attract the interest of the society. In this context the societies as well as the markets respond to big streams like technology advances, demographic changes, economic stability and more recently sustainability and environmental awareness. Those variables are studied and matched by car manufacturers, who develop products that can fulfil the needs and aspirations of the people. In recent years the environmental awareness is raising and many manufacturers are taking steps to more sustainable methods of transportation, in collaboration with universities and investigation centres. Every year more electric options are available in the market, leading to a blended segment of cars where the main feature is the propulsion system. This segment includes the people who are concerned about the environment, but also with new options like electric luxury cars, the technology encompasses those who demand style and performance.

### 2.1.2 Electric car evolution

Needs and likes have changed along the history, creating new designs in response to style and fashion. It is appropriate to say that the biggest driving force behind the main changes in history have been men's desire to achieve higher goals and the creativity to find new solutions. In the automotive history, the great leap has always been the technology innovation, either power-driving or manufacturing. A major breakthrough in technology can impulse or hinder the development of cars (Macey, 2014). It is quite difficult to trace the technology through the time, many inventions that are considered new have been in the world for many years before, but used in other application field. For example the differential mechanism was used by watchmakers before the car adaptation (Happian, 2001). In the early stages of the automobile the main technologies were the steam motor, the electric motor and the incipient combustion engine. For many years electric vehicles dominated the markets, being perceived as reliable, safe and good. These vehicles were a little more expensive than their competitors, but were well constructed, offered a good range and people even competed in races. However, electric and hybrid vehicles have a colorful past, filled with ingenious inventions, patent wars and idealistic goals (Anderson and Anderson, 2010). It is ironic that the great development of the electrical engines meant it's own death by coupling the electrical starter to internal combustion engines. After that golden era of electric cars the internal combustion engine took the place as the main technology and the electric cars stopped production in 1930. Since then there has been a lot of research

and development on the body work for combustion vehicles, changing the architecture and style of cars, but the combustion engine has changed very little in shape and principle since 100 years.

However it is important to understand that the evolution of cars is a large process and takes many years for new technologies to be accepted and used at its maximum. As an example there is a comparison between a horse chariot from beginning of XX century and the 1903 Krieger Brougham, which was one of the first hybrid electric vehicles (see figure 3 and figure 4). The similarities in the architecture are remarkable and it would not be exaggerated to suppose that the electrical technology was coupled to the existing animal powered chariot just to make it move.

This early disappearing of the electric vehicles has done that now days the electric cars are considered new technology, and even a novelty. Nowadays mostly all the development on electrical cars is done towards the powertrain, to make the batteries more efficient, charge them faster and make those more accessible in order to compete even with ICE cars. However, there is little development about the bodywork, and the current solutions can be compared to the horse chariot example, where the new technology uses the old architecture of the previous one.



Figure 3, Horse chariot

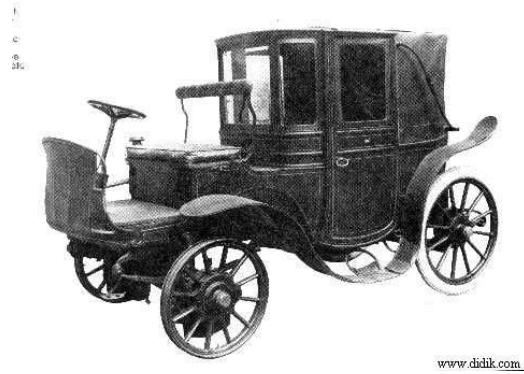

Figure 4, 1903 Krieger Brougham hybrid electric vehicle. Front wheel-drive electric motor, 60Km range.

### 2.1.3 Car base

The car base set important factors for the development of this project. It is the vehicle which is going to be analysed in terms of structure and architecture; it will be the reference for benchmark and also is the base to develop an electric concept.

The important factors to decide on the car base were dimensions, CAD models and drawings availability, the size of the car to be analysed, the relation to a comparable benchmarking alternative, and also the technology compatibility, meaning the adaptability for electrical technology coupling. A Pugh decision matrix was used among the possibilities presented by the company. The scale was -3 to +3. No reference was used.

	S90	XC90	V40
Availability	+3	+3	+3
Size	+2	-1	+3
Benchmarking	+3	-2	0
Technology compatibility	+2	+3	0
Total	10	3	6

Table1. Decision for the car base to be analyzed

From this evaluation it was decided to take the Volvo S90 as the base car, because the company can provide the CAD models for

analysis. Another important point is that it is comparable in many ways to the main electric competitor that will become the benchmark vehicle. It is also positive in technology compatibility as the size of the car is big enough to allocate a battery package with relative freedom. Another strong point for the S90 is that it is built over the SPA platform, which is the new architecture Volvo use for their new models. It is highly adaptable and customizable which allows the development of many different car models. At the same time the SPA presents some restrictions, the distance from the center of the front wheel axis to the dashboard is set (figure 5), but all other distances can be changed. This point is relevant because Volvo considers the dash to axle distance as the entry to the premium segment because it symbolizes premiumness, as historically large engines had to be allocated in long bonnets (Missoni, 2016). This creates a boundary and becomes one of the design requirements.

Finally the SPA permits the construction of different car concepts, which can be considered when a new electric concept is presented.



Figure 5. Volvo SPA Platform

## 2.1.4 Dimensions

The car base determines the dimensions and proportions to be analyzed. In general the car has been designed to look longer, wider and lower than the competition; those proportions constitute one of the main identity points of the S90. However in this stage, the dimensions are to be interpreted in a questioning way, asking why the components are arranged in certain positions and how the packaging works. The vehicle dimensions set also some of the most

important design requirements like the position of the front axle and the position of the A-Pillar, which is the basic set of the SPA (Figure 6).

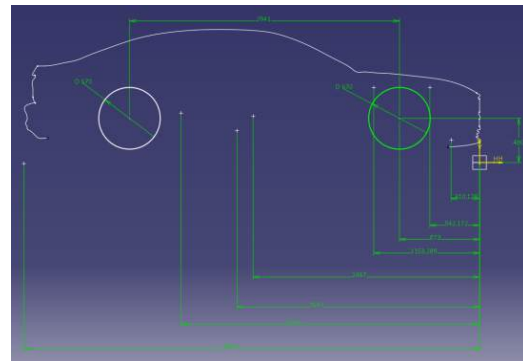

Figure 6. General dimensions of the car

## 2.1.5 Wheelbase and A-Pillar

The wheelbase is one of the most important dimensions of the vehicle; it is the distance between the front rear axle centers. The S90 has 2941mm of wheelbase which will be used as one of the requirements for the development of the concept.

## 2.1.6 Enter CG position and height

The center of gravity is one of the critical factors in car design. It has direct influence on the weight of the car, the balance, the equilibrium and the load paths and that is the reason for the positioning to be important. In general the lower the GoG is, there is a better distribution of the loading forces to the front during braking, to the rear during acceleration, and to the outside wheels during cornering. As the CoG is a three dimensional point in space its reference datum is located by a coordinate system. The sprung mass is considered as a rigid body, in this sense it has six degrees of freedom (DOF), three translations and three rotations, roll along the X-Axis, pitch along the Y-Axis and yaw along the Z-Axis (figure 7). As empirically experienced in a regular car, a person can feel that the car dives down at the front when braking (pitch) rolling at cornering

(roll) and sitting down at accelerating (pitch) (Happian, 2001). Even when those phenomena are controlled by the suspension system, the center of gravity has big influence on the momentum magnitude of those forces. All those forces that not pass through the point will make the car rotate (yaw), in that sense is important that is centered in the horizontal direction. The position of the CoG in the longitudinal direction is basic to determine the braking and accelerating forces. The optimum location would be as low as possible and in a position in the center of the wheelbase, as this put more weight on the rear axle where the traction system is located.

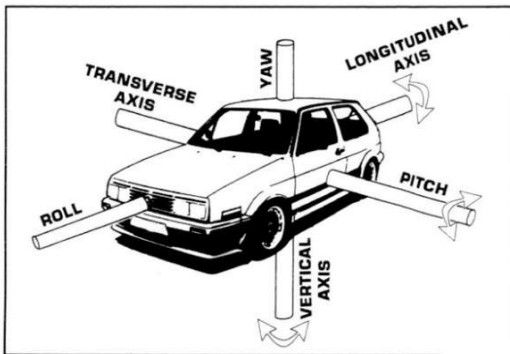

Figure 7. Roll, pitch and yaw motions.

The center of gravity is the balance point of the vehicle, the point which the gravity moments are balanced and where the force cause pure translation. The CoG is affected by the weight distribution of the components, including body in white, upholstery, passengers, electric system and other components. In this scenario the weight distribution of the traction system have a big impact on the location of the CoG, especially considering the total mass of the components. The usual combustion engine plus the transmission vary from size, capacity, cylinders and other variables, however, a common engine of 4cyl can weight up to 364 lbs.

Weight comparison	
Component	Weight lbs.
Chrysler 2.8 liter 4cyl plus transmission	524
Tesla battery pack	1200

Table2. Tractive system weight comparison

In contrast the battery of a Tesla car weight 1200 lb. creating a totally different set for the packaging and weight distribution. Presumably this is the main reason for that manufacturer to design a flat battery package on the floor, in this way the CoG can be located in a lower position in the Z-Axis (figure 8). The following plots are approximations of the CoG location on two different vehicles, the base car, Volvo S90 and the electric car Tesla model S. The intention is to show that the geometry and location of the tractive system have direct influence on the location of the center of gravity in the vehicle (figure 9).

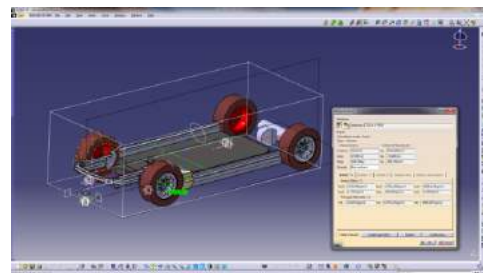

Figure 8. Tesla flat battery positioning below floor

Center of gravity Tesla	
Gx	2101,4 mm
Gy	-0,4 mm
Gz	288,7 mm

Table 3. Tesla CoG coordinates

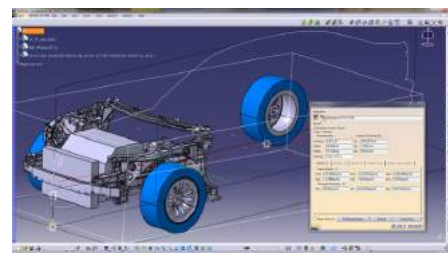

Figure 9. Volvo S90 tractive system positioning



Center of gravity Volvo S90	
<b>Gx</b>	2581,8 mm
<b>Gy</b>	-0,56 mm
<b>Gz</b>	559,5 mm

Table 4. Volvo S90 CoG coordinates

### 2.1.7 Body-in-white

Body in white (BIW) is the structure of the vehicle architecture. It holds the components together and is the base of the car. It is usually divided in three main parts, the front engine bay, the passenger cabin and the rear trunk. Each section has its own purpose and characteristics. The project focuses on the frontal engine bay where the IC engine can be found (Figure 10). The BIW is manufactured using stamped sheet metal to get the designed form and then weld together using spot weld. The resultant structure is very stiff and because it works as a unit it is called monocoque. The monocoque distributes the dynamic loads of the normal car operation among all the surfaces, becoming a very complex structure. (EAA, 2013). In the event of a crash the monocoque derives the forces along the side rails or side members to the floor structure and to the roof structure (Figure 11) (Azizan, 2014). Modern vehicles use the engine bay as a crumpling zone for absorbing the energy of an impact and decelerate the car in the event of a crash (Brown, 2002).



Figure 10. Chevrolet Camaro 2007 BIW

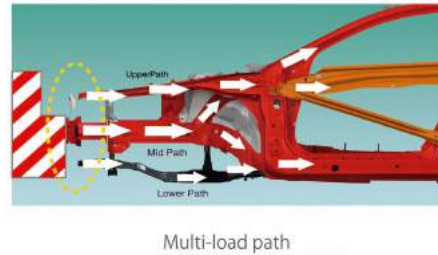

Figure 11. Load path along the BIW

### 2.1.8 Benchmark

There are many electric options in the market, and most of them are adaptations of their combustion engine counterparts. Hence those cars use the same platform and same architecture. The benchmark vehicle has to be developed as an electric vehicle from the beginning in order to compare the latest real-world solutions. For this purpose the Tesla model S was selected, because it is a comparable car for the S90, in dimensions, power, segment and features.

## CRASHWORTHINESS

### 2.1.9 Moderate overlap crash test

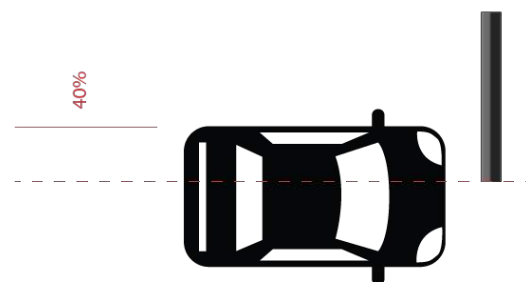

Figure 12. Moderate overlap test

There are several types of accidents that may occur while driving, whereas the frontal crash results in the high rates of deaths and serious injuries. In most cases, a frontal crash occurs when two oncoming vehicles collide at similar

speeds. Hence, there is an frontal impact on both vehicles which consequently puts them offset. In the moderate overlap test one vehicle moves at a speed of 64 km/h into a deformable barrier representing a second vehicle (NCAP, 2016) (Figure 12). The car is impacted by the 40% of the vehicle width which means that just one of the two side rails absorb energy. What is useful in this test is the insight that crash forces need to be directed to certain parts of the car in an efficient way so that the energy can be safely absorbed. It is essential that the frontal vehicle structure controllably collapses to avoid deformation in the passenger compartment and serious injuries among the passengers (Figure 13).



Figure 13. Example of a vehicle impacted on a moderate overlap real situation

### 2.1.10 Full Width Rigid Barrier

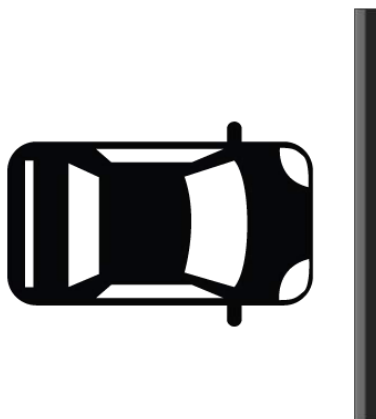

Figure 14. Full rigid barrier test

Recently, the structures of vehicles has developed and become stiffer which has contributed to both positive effects and new challenges. Since the risk of the passenger compartment to collapse and deform is lower, leg and head injuries have been reduced. Although, stiffer structures contribute to higher compartment decelerations which can result in serious injuries in the chest area of especially smaller or elderly passengers. One way of approaching this challenge is to test the vehicle driving at a speed of 50 km/h and crashing into a barrier with full width (Figure 14). The structure design of vehicles is still being discussed and optimized, as well as the restraint systems. According to strong recommendations from agents in the industry, geometry and level of stiffness are considered necessary for be able to reduce incompatible real field situations. (NCAP, 2016).

### 2.1.11 Small overlap frontal test

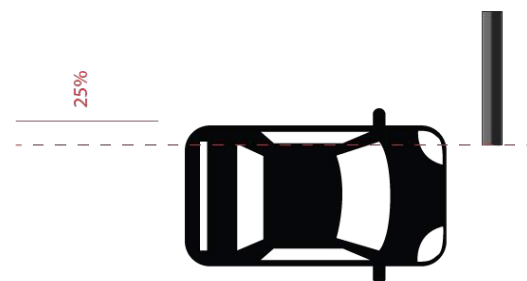

Figure 15. Small overlap test. 25% offset.

Small overlap represents the collision of a vehicle with a post or another vehicle when the driver has not been able to avoid the impact completely. The test is developed with a vehicle traveling at 40mph into a rigid barrier. The vehicle is impacted on 25% of the total width (Figure 15) (IIHS).



Figure 16. Example of a vehicle impacted by a small overlap real situation

The test evaluates the stiffness of the cabin compartment and the dissipation of energy from the outer edges of the car. This is considered the most difficult test for manufacturers due to the minimal energy-absorbing structure that is exposed. It is quite common for the vehicles to crush the frontal side of the car and receive the impact with the A-Pillar column (Figure 16).

### 2.1.12 Fork case

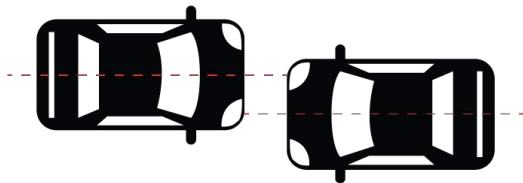

Figure 17. Horizontal vehicle misalignment

Vehicle incompatibility is driven by different variables like materials, vehicle velocity, geometry and others. Reza and Simkus, studied on their thesis at Chalmers (2011) how the configuration of the vehicle subframe can influence the crash behaviour in two different scenarios, a Progressive Deformable Barrier (PDB) and a Car-to-Car case. The structural compatibility is accomplished when the structural elements reach their pairs of horizontal and longitudinal parts on a collision, balancing the forces along the load paths and creating a dynamic equilibrium (Figure 17). According to the investigation of FIMCAR, (Johannsen, 2013), in frontal car-to-car collisions as well as small overlap there is a risk of impacts with a fork effect (Figure 18) which

is the misalignment of the elements and load paths in the event of a collision. Some of the conclusions included in the investigation are follow up critical concepts as structural alignment and structural interaction.

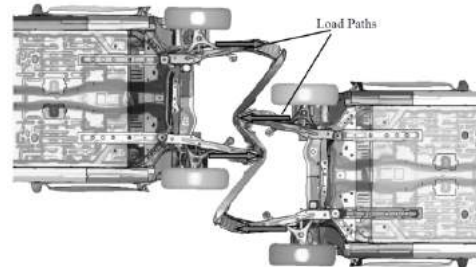

Figure 18. Fork effect on two collapsing vehicles car-to-car misalignment. Reza and Simkus, 2011, Chalmers

### 2.1.13 Front pole crash

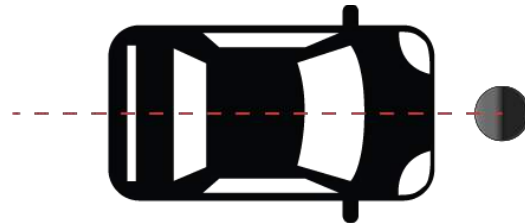

Figure 19. Front pole in the middle of the car width

Front pole is a kind of crash that currently isn't evaluated, neither from NCAP nor from IIHS. The vehicle impacts a stiff pole in the center of the width, missing both sidemembers for energy absorption (Figure 19). This poses a very difficult case for manufacturers and designers. As the vehicle has no structure elements to stop the vehicle and absorb the kinetic energy, the intrusion rate is increased in this kind of impact (Morgan, 2012) (Figure 20).



*Figure 20. Real examples of a front pole impact*

### **2.1.14 Vehicle incompatibility**

Crash incompatibility is a large and complex problem. It encompasses several variables which are impossible to control in the real world, like the velocity of a vehicle, geometry of the crashing vehicles, structural materials of

both vehicles and many others. There are many types of car incompatibility like, front to end, front to side and even front to front. In the study performed by (Bae, 2000) for Hyundai Motor Company, the risk of intrusions is even higher when vehicle incompatibility is added to the scenario, where not just the longitudinal and horizontal structural members are misaligned by an overlap, but a vertical misalignment cause that stiffer parts of the vehicle are pressed in the other vehicle, displacing softer elements that can intrude the cabin, creating a dangerous situation (Figure 21).



*Figure 21. Front to end vehicle incompatibility*

## 2.2 ANALYSIS

According to (Wishc, 2014), the crash analysis for the design of electric vehicles needs to be based on conventional vehicles, by the fact that the vehicle structure is constructed according the standards that have been set from many years of investigation and testing. This statement is the base for the solutions derived in this chapter, where the electric vehicle structure architecture is conceptualized by analysing different crash situations.

### 2.2.1 Small overlap analysis

The evident problem presented by the small overlap is the sidemembers neglecting the impact wall, causing an inoperative system where no structural element absorbs energy. Many videos of the small overlap were analyzed trying to find patterns and common behaviour. Also an interview with Andreas Lundviqst, head of the body in white department at Volvo was performed in order to understand the effect of the small overlap in the SPA platform and how Volvo manages to get a high score on the test.

In Figure 22 and Figure 23 it is possible to appreciate the crash of two different vehicles impacting the front axis. Around the same distance of crashing, it is noticed that Volvo leans to the side while Audi keeps the straight forward way. The difference in the Y-Axis displacement of the car represents a big difference for test outcome. The preferable behaviour is the car to jump to the side instead of absorbing the energy of this kind of impact. This small shifting of direction is the effect of the compression of the structure in the Y-Axis. The effect is triggered by the bending of the bumper beam which hits the wheelhouse in the point where the transmission stacks up between the monorails, in order to stiffen the structure in the horizontal direction.



Figure 22. Volvo XC90 2016 small overlap test

As the impacted area is not big enough to absorb the kinetic energy, the preferred solution is shifting the car to avoid any direct compression of the cabin in order to enhance occupant protection. However a complete shift is not entirely achieved as can be seen on the shattered windshield corner, so the cabin structure has to be stiffened for this purpose (Figure 22).



Figure 23. Audi Q7 2017 small overlap test

In the case of the Q7, by the time the wheel axis is aligned with the impact wall the wheelhouse is completely crashed and no longer deforms, then the lateral compression starts to buckle the left sidemember and move the car in Y direction as the right side member continue the acceleration in the X-Axis going forward, creating a

momentum in the firewall cross members. The torque boxes have to withstand those forces and maintain the stiffness of the structure, however this increase the stress on the structure before impacting the A-Pillar (Figure 24). Once the A pillar is impacted it can be seen a small buckle on the roof as effect of the distributed loads along the monocoque. However the stiffness of the structure creates a bouncing effect almost immediately after impact.



Figure 24. 2017 Audi Q7 small overlap test load path

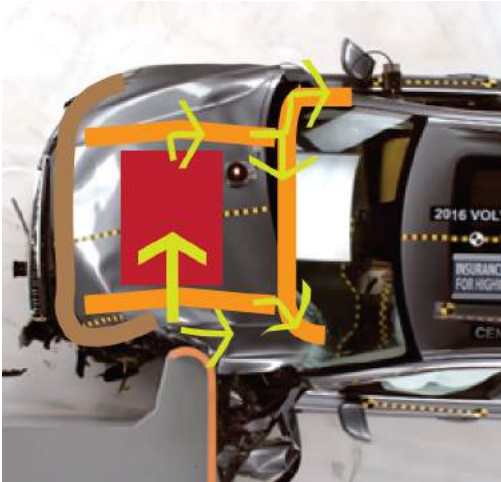

Figure 25. 2016 Volvo XC90 small overlap test load path

The Figure 25 shows the load paths on the XC90. The components in the engine bay create a horizontal stack between the sidemembers where the entire front structure is stiffened enough to move the car to the side. The first impact bends the edge of the bumper beam which impact longwise on the left sidemember. The stack of the engine components creates a ladder connecting the bumper beam, stack and firewall. Both sidemembers are compressed and

buckle along the Z-Axis due to the minor inertia moment of the geometry. A moment is created in the firewall because of lateral compression. The roof buckles on the rear part of the vehicle.

The goal of the structure is to lower the impact for the cabin. The vehicle shifts in an angled way after the wall contact the sidemembers stack. When the A-Pillar reaches the wall the entire vehicle has been displaced in the Y-Axis enough to minimise the impact.

## Current EV situation

In the modern electric vehicles the frontal structure consists of two sidemembers joined by a sub frame, leaving a generous space to accommodate components and luggage. Figure 26 shows two different electric vehicles, after simple inspection it can be inferred that the small overlap case would have a similar behaviour as seen on the Q7. With no structural features to absorb energy it would be expected that the vehicle crash into the test wall will have almost no restrain for a consequent impact on the A-Pillar.



Figure 26. Frontal structure of EV. (a) 2014 BMW i3. (b) 2013 Tesla model S

As a conclusion of this analysis it can be said that Volvo has accomplished a good understanding of the small overlap test, and the solution is applicable to vehicles where the solid combustion engine can stack up in order to shift the car in the Y direction. However, for electric vehicles, the space between the sidemembers doesn't provide sufficient stiffness for the vehicle to displace laterally.

## 2.2.2 Moderate overlap analysis

The moderate overlap crashes the vehicle in the frontal direction by 40% of the car width into a deformable barrier, (Figure 27). It is possible to see how the front of the car deforms largely in the impacted area, but not in the free end of the car. The intention of the test is to maximise the safety by ensuring that the side elements are capable of stop the car individually.



Figure 27. 2016 Volvo XC90 moderate overlap

### CAD model

The sidemembers around the engine bay were CAD modelled to run an analysis of the crash. A simpler model was developed using surface design. The dimensions are loyal to the original car model, however some of the elements like the firewall crossmember and the torque boxes on the firewall were integrated into the sidemembers. The simplified model is a closed surface with no bonding or welding for analysis, following the work done by (Bastien et al, 2015) (Figure 28).



Figure 28. CAD model context of the frontal structure of a XC90

In order to understand the effect of the crash a finite element analysis was done. For the side rails it was used a surface to create plate elements, this surface was a representation of the sheet metal design (Ohsaki, 2011). The plate elements were assigned a thickness of 1,55mm and the wall was represented by a thick plate of 20mm. The material applied is aluminum to the structure and steel for the barrier. The load case applied is solved using ANSYS explicit dynamics module (Figure 29).

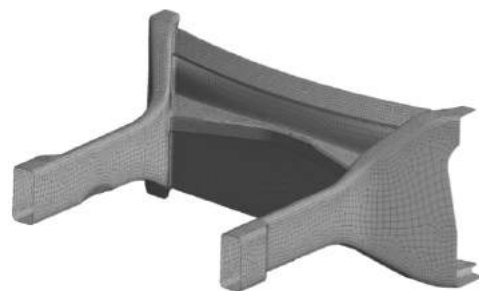
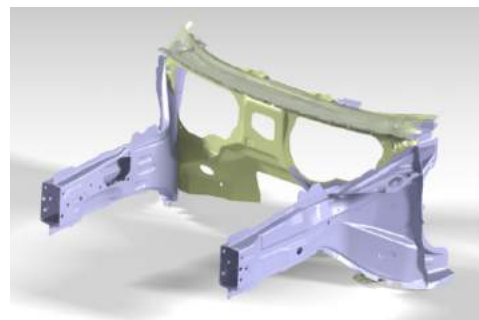

Figure 29. Finite element mesh

## Analysis

The side members act individually when crashed into the wall. On the Figure 30 it is possible to see the deformation of those two. It was applied a velocity of 13,3 m/s. The left sidemember deforms and absorb the energy of the impact; however the right member is not activated. The stress is distributed along the member. Then it goes to the floor structure and the A-Pillar. The firewall distributes the stress on the Y direction.

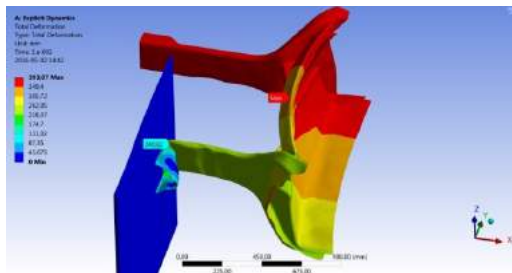

Figure 30. Total deformation of the sidemembers, plate elements model

Total Deformation	
Sidemember datum	240,82 mm
Max deformation	393,07 mm

Table 5. Total deformation

The displacement of a datum in the sidemember results in 240,82mm in the X-Axis. Comparing it with the maximum displacement it is

$$\Delta y = \Delta X - \Delta x_1$$

$$s = 152,25 \text{ mm}$$

The difference in displacement can be used to understand what force is being absorbed by the work one of the deformed member.

$$F = \frac{\left(\frac{1}{2}mv^2\right)}{s}$$

Assuming the mass  $m$  is a unit and  $v$  is 13,3 ms

$$F = 580,91N$$

This is the slowing down force that the member absorbs by itself with an imaginary mass of one unit. This force could be managed to get split in two by activating the other sidemember.

The maximum stress is concentrated in three points along the sidemember, after the coupling of the crash boxes (A), on the engine mounting points (B) and on the split for the Upper A-Pillar and the floor structure (C) (Figure 31).

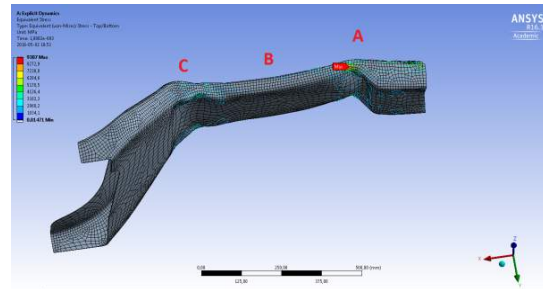

Figure 31. Bending points along the sidemember

According to the failure design the side members defect open in a Z shape (Figure 32). The opening points are the engine mounting points. This is designed to increase the space of the engine bay and make the engine fall after losing the supports. Drop the motor during the impact has two main effects. First it will avoid any intrusion into the cabin, because the motor is a solid structure than can pierce the firewall. Second effect is to decrease the mass during impact and reduce the dynamic energy.

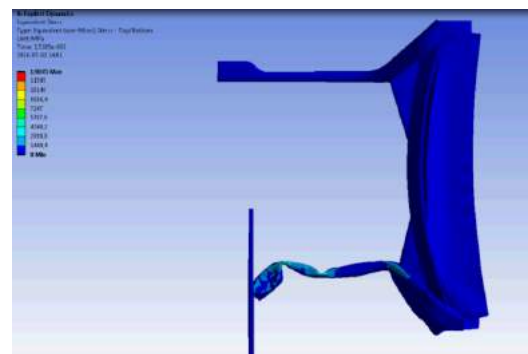

Figure 32. 'Z' shape failure design



### 2.2.3 Openings and access to components

The engine affects and modifies the bay, different requirements means different configuration. Smaller IC cars can accommodate the motor and fit all components in a much reduced space. For larger engines the nose of the car prolongs largely. Electric vehicles are slightly less space demanding in the front of the car. Nevertheless, the electric system components are much more complicated than the IC components and this difference creates a knowledge and technological barrier for regular people to handle or modify the internal components. In less than 10 years the engine compartment has loosen access to many of the components inside the engine bay, as they become more and more complex which requires specialized technicians to handle those. The Figure 33 and Figure 34 show a comparison between the accessibility for different components between two generations of XC90, it is noticeable how the new model have covered most of the engine bay opening with black plastics, leaving access just for the basic adjustments available to the user. More specialized work has to be done by qualified technicians.



Figure 33. XC90, 2007 Engine Bay and components



Figure 34. XC90, 2015 Engine bay and components

In the same tone as IC cars, the electrical vehicles prefer the minimal user interaction with the internal components. For electric cars the components enclosure is even bigger, leaving the minimal opening interaction available for the user as it can be seen on the examples on Figure 35, where the only available interaction point is the wipers fluid tank lid.



Figure 35. BMW i3 front storage

## 2.2.4 Frontal storage space

The BMW i3 is a compact, user-friendly electric car, simple to use and fun to drive. The compact size of the car restrains the baggage space in the front. This sets to the minimal the area, just leaving a space big enough for the charger. Bigger electric options like Tesla have a more spacious frontal baggage storage place, however according to a survey around a small group of Tesla owners, 25% of the population has no use of the frontal baggage compartment, followed by a 31% of occasional use (Figure 36).

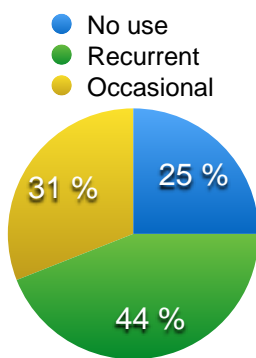

Figure 36. Frontal storage use of the Tesla Model s

Furthermore, within the group that declared recurrent use of the frontal storage space, 71% corresponds to permanent use for common car accessories like tools, cables, chargers, adapters, cleaning clothes and even a spare tire (Figure 37). This figure leads to a simple conclusion, the frontal trunk is largely misused, even more, the main use of the frontal space is to storage car-related articles for maintenance, most of them not vital in any way for the correct function of the vehicle, with the charger exception.

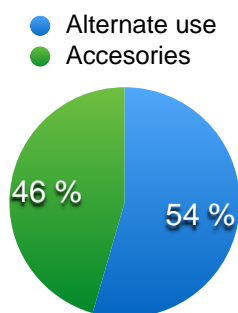

Figure 37. Recurrence of use

## 2.2.6 Functional model

The model divides in two main parts which correspond to the main parts of the thesis, those are the structure and the style design. From the structure part comes the main sectors to be addressed, which are the bumper, the crash boxes, the sidemembers and the firewall. From the style comes the requirements to be addressed which are the aerodynamics considerations, the user studies for the segment, the brand identity for design cues, the packaging for the different components and the ergonomic boundaries.

The functions are defined as the springs of the main spheres of design. The goal of the model is to grow from an open idea to details of the system, creating the functional connections between them. The outcome of the map is the interaction demands, which are the connections between the structure and the style. Which in this case meet in the front structure of the body in white.

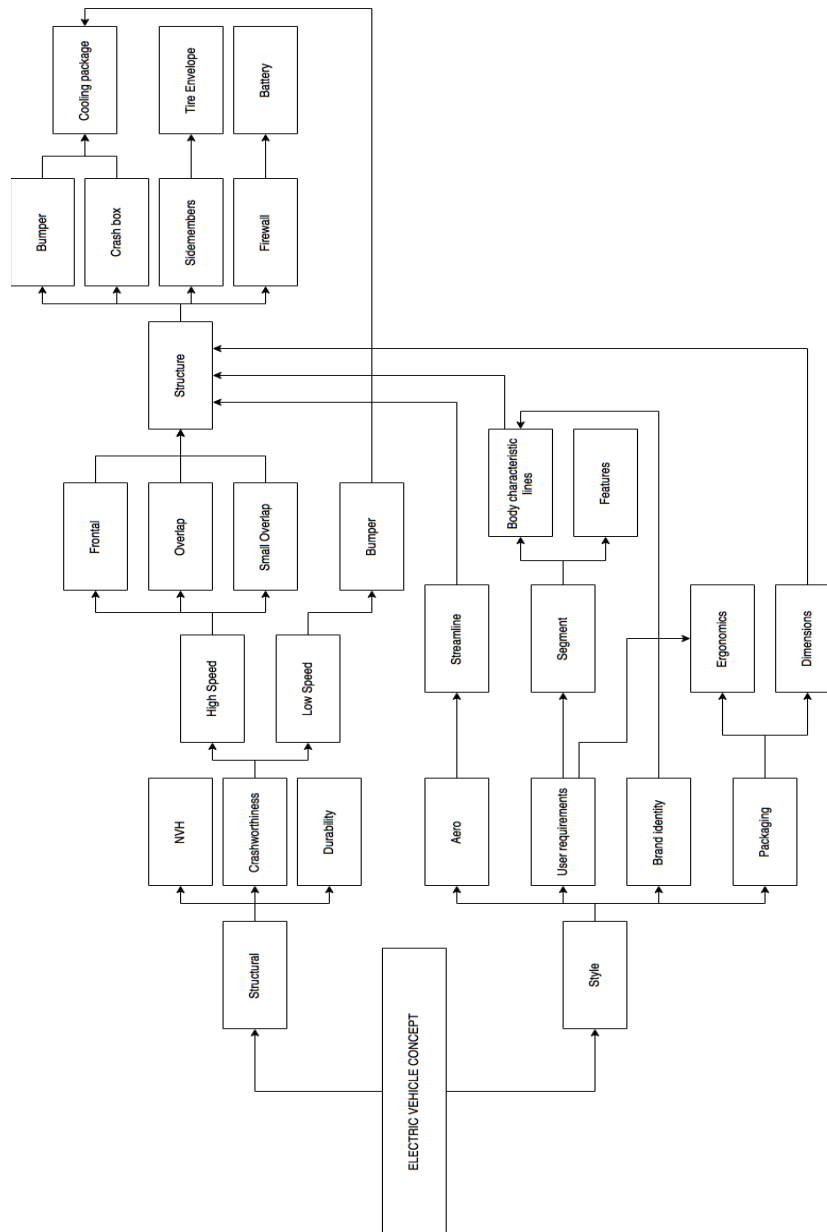

Figure 38. Funcional model

## 2.2.7 Solution model

The solution model takes all the interaction demands derived from the functional model and sets a correlation to a specific proposal that can represent a feasible solution. This map of solutions are individual but could be connected to one or more interaction demands.

As the interaction demands connect to more solutions the model becomes more complex and connections among solutions are evident. This map helps to understand what components are affected by a particular solution. On the other hand also reveals what aspects are important in order to develop and optimise a certain solution.

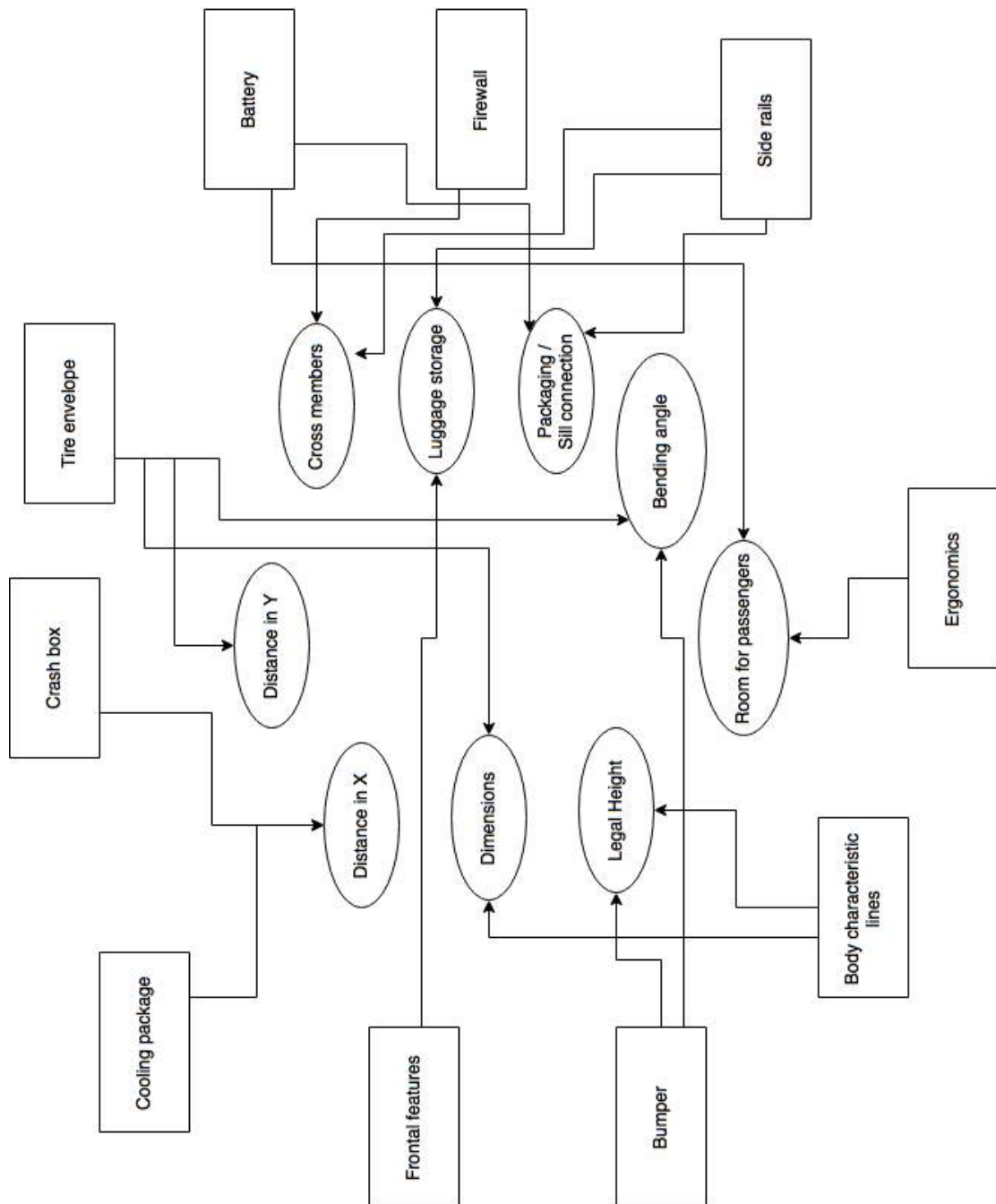

Figure 39. Solution mode

## 2.2.8 Interview analysis

### Chalmers

Three interviews were performed to elide information about the project approach. The interviews have been a fundamental method to obtain the ideas, opinions and positions of experts on the topic.

A big asset in the development of the thesis has been Erik Westerlund who has vast experience in crashworthiness and body-in-white development by the experience gained at Volvo trucks and Volvo cars. Also part of the development of the Volvo XC90 2014 frontal structure. The knowledge and guide have influenced this work in a big manner.

An interview was performed with Teedy Hobeika about the aerodynamics of the car and cooling packaging. At the moment Teddy Hobeika is writing his Phd thesis at Chalmers on aerodynamics.

### Volvo interview

The Body-in-white department at Volvo agreed on an interview to talk about the design and development of the BIW. The thesis topic was presented and the main points were discussed. The tone of the interview was performed as a semi-structured interview in order to obtain as much free thinking and information as possible. The Volvo Interview

with Andreas was analysed using the KJ method (Figure 40).

The discussions and ideas were arranged in eight groups.

- Boxes packaging
- Open box idea
- Floor and sill
- Structure
- Battery
- Firewall
- Plate
- Hood

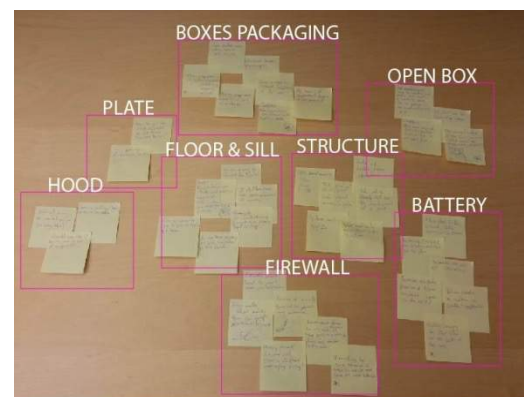

Figure 40. KJ method for interview

The topics were evaluated subjectively according to the experience of the BIW department. It was clear that the electric alternative for a vehicle posed many challenges for the designers and that the department haven't brought to the table many of the challenges that an EV represents.

## 3. CONCEPT DEVELOPMENT

This chapter describes the thinking process used to build solutions for the questions posted in the planning of the thesis, using the insights obtained on the analysis phase.

# CONCEPT DEVELOPMENT AND DESIGN THINKING

Design is an iterative process where an idea has to meet specific requirements, and then it is evaluated and refined according to the design goals. In this chapter the ideas were analyzed and discretized in base of the crashworthiness structural criteria for the BIW and the user studies for the body style design. The ideas are developed and compromised with each other to fit the functional and solution model.

## 3.1 Unity of the concept

The aim of the thesis at this stage is to analyse the BIW crashworthiness structure using design process to come with solutions that perform good on tests, and construct the style design around those solutions. This process goes in an opposite way of the traditional way of car development, where everything starts with the style. However, this project address the safety as the most important factor of development.

In order to achieve this, there are considered three main spheres that will be developed simultaneously. The BIW, the style design and the interaction demands that connect both. The combination of those three will come with the front structure requirements, which together will create the EV Concept (Figure 41).

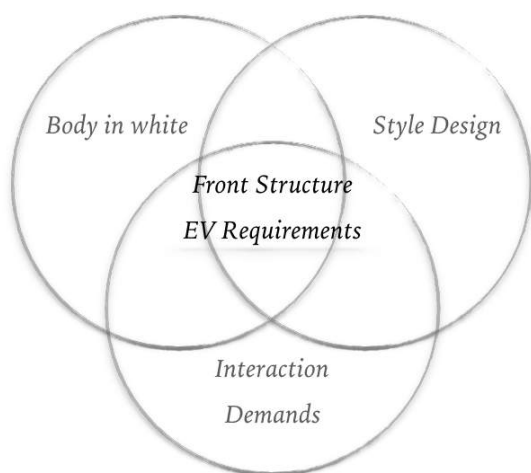

Figure 41. Concept design spheres

## 3.1 Solutions for small overlap

One of the first stages of the concept development addressed the small overlap as a frontal impact case and attempted to absorb the energy through the sidemember (Figure 42). Even when the small overlap is considered as frontal impact test, the modern way to address the case is deriving the frontal force to lateral force in order to the car to shift in the Y direction as it was demonstrated in the analysis phase. In order to consider alternatives for the test case some sketches of inclined the sidemembers were done. Two different inclinations (a) divergent and (b) convergent were analyzed. Both present big flaws for the overall structure. Divergent sidemembers would create big momentum in the firewall connection point along the Z-Axis. On the other hand convergent sidemembers present a packaging problem, by leaving no space for the tire envelope. After this it was obvious that a different approach should be taken on this specific case.

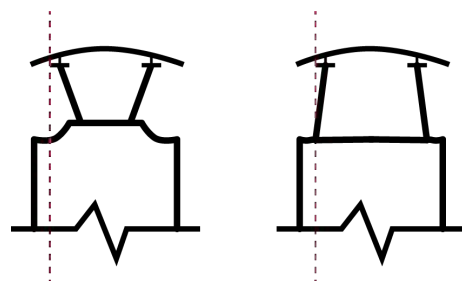

Figure 42. Inclined side members. (a) divergent, (b) convergent. Relative to origin point.

## Development and evaluation

After visiting the Volvo BIW department it became clear that the SPA current solution address the small overlap as lateral loads, it is optimized and bring good and constant results as shown on IHHS results.

The bending of the bumper hit the side members longwise, which derive the force to the gearbox and the engine to stack up and create a ladder to move the car sideways in the small overlap crash test, as it can be seen on the research chapter of this report. However, in current electric cars (Figure 43) the lack of solid components to stack up presents a situation that can be represented as a simple cantilever beam under lateral loads.

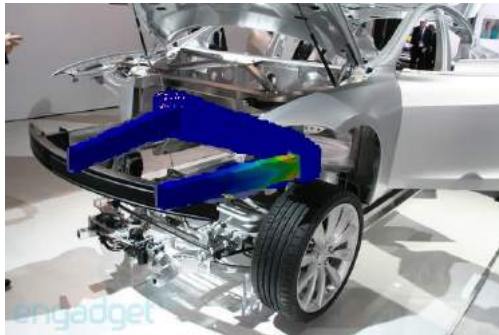

Figure 43. Current EV structure

### Cantilever beam case

The goal of the design is to shift the car in the Y direction. To succeed, a stiff structure which can withstand the forces of the impact and not deflect in excess is necessary. This case does not demand absorption of energy but displacement of the body. A simple model of the sidemembers was created to understand the load case. The material is aluminum, same as the Tesla Model S structure, plate elements mesh was used for the finite element model. The lateral load for this simulation is 5000N. In Figure 44 can be seen that a cantilever beam tends to deflect creating maximum stress near the anchored end and maximum displacement near the free end.

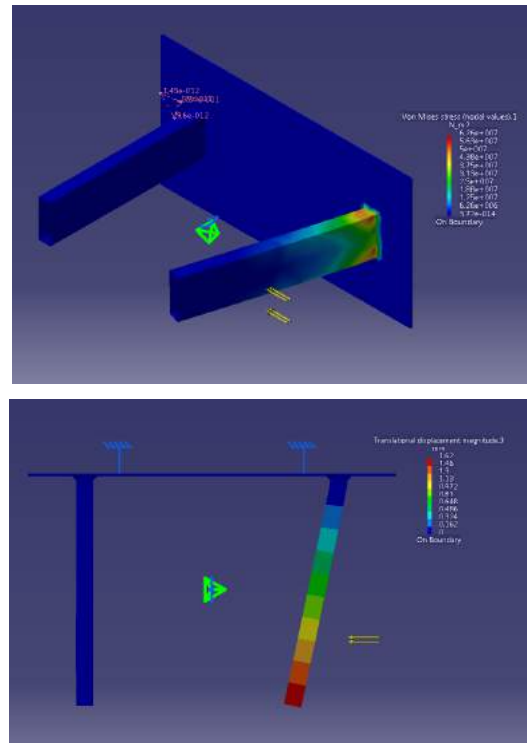

Figure 44. Representation of sidemembers as cantilever beam.

Cantilever beams	
Maximum stress	Displacement
62,6 MPa	1,62 mm

Table 6. Cantilever beam stresses and displacement

### Open frame

In order to recreate the scenario where the engine and transmission are stack up, the possible solution is to add a cross member connecting both sidemembers (Figure 45). The system would differentiate from a sub-frame because the cross member would be an integral part of the structure instead of an underneath add-on. The cross member is placed in the lateral force application point to carry as much force as it can. As it can be seen on the data generated, the solution adds stiffness to the structure by decreasing the total displacement 3,97 times.



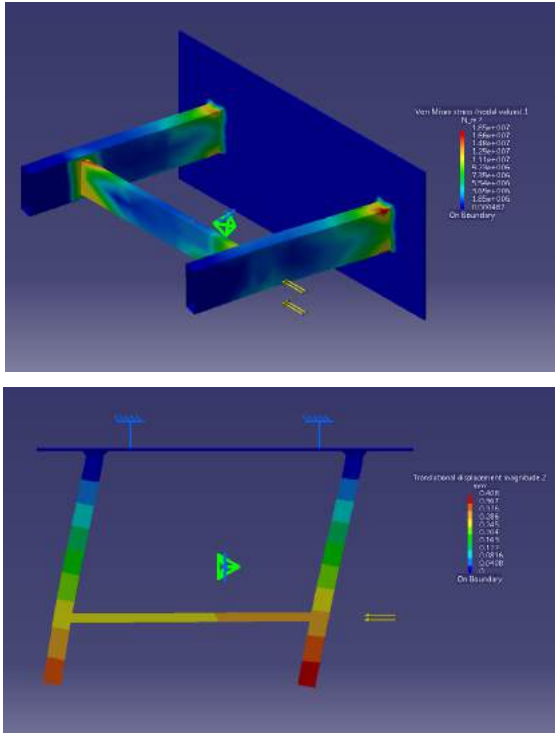

Figure 45. Representation of sidemembers as an open frame structure (a) stress (b) displacement

Frame design	
Maximum stress	Displacement
18,5 MPa	0,408 mm

Table 7. Open frame case, stresses and displacement

The open frame design presents deflection of the beams and generates momentum on the joints. As it can be seen in the Figure 46, from (Happian-Smith, 2001), the stiffness of the structure rely on the strength of the joints to withstand the forces and momentum, where the welding of those joints becomes crucial to keep the structure. This can be seen on the maximum stress points on Figure 45 (a) which are painted red.

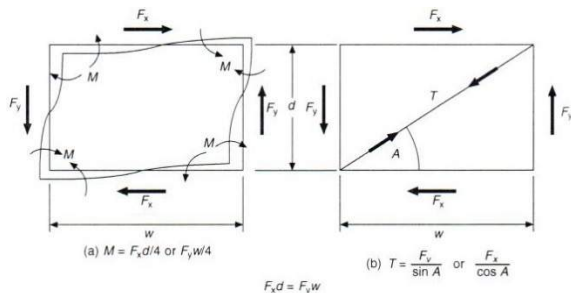

Figure 46. Ring frame and diagonal braced frame (source: Happian-Smith, 2001)

## Truss design

Considering the triangulation for the frame, a diagonal member would act carrying axial forces of compression. In the context of the sidemembers for the car structure it would be:

$$F_x = \cos \theta * T$$

and for lateral force impact

$$F_y = \sin \theta * T$$

To address the bending of the beam in the Y direction and the momentum in the Z-Axis, the structure was redesigned as a truss structure, and then an angled cross member was added.

The angled side members can take lateral loads to move the car in the same direction because the structure is stiffer in the Y direction, as it can be seen on the obtained data, the displacement in Y was decreased 2.07 times (Figure 47).

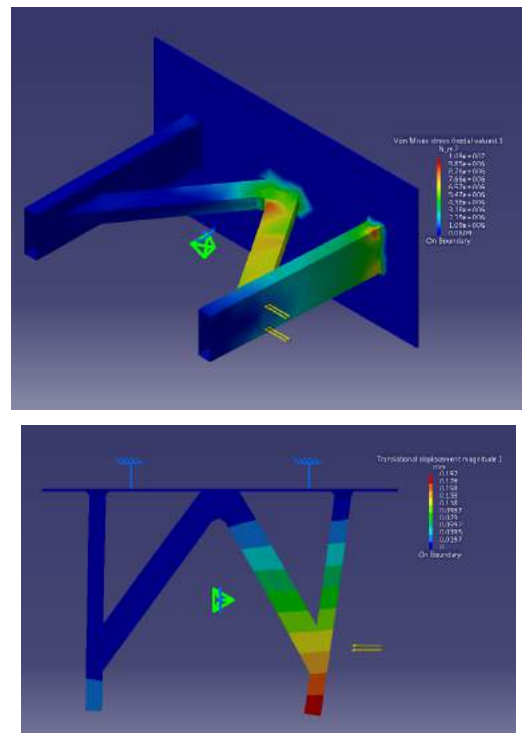

Figure 47. Representation of sidemembers as truss structure

Truss design	
Maximum stress	Displacement
10,9 MPa	0,197 mm

Table 8. Truss design, stresses and displacement

The triangulation transmits the loads through the angled cross member to the firewall. Therefore it needs a solid structure in the back to take the load and derive those loads.

### 3.2 Solutions for moderate overlap and fork case

Side rails are probably the biggest carry over of the combustion engine car. At the same time they are the main energy absorbers in a crash, protecting the passenger's cabin and minimising the pulse of the impact. In the moderate overlap load case, energy is absorbed only by one of the side rails, which collapse and stops the vehicle. However, sidemembers are designed to act together as its best, in order to decelerate the car and prevent intrusions. The proposed way to address this issue is connecting both sidemembers; in this way when a misalignment exists, both sidemembers are going to work together absorbing energy and decreasing the pulse for the driver.

The sidemembers need a solid stiff structure to hold and absorb the energy of the impact. On the combustion car the side rails hold the motor and are stiff enough to maintain structural integrity. Once the battery pack is added to the BIW, the CoG of the car shifts position, and the CoG of the battery is located under the floor. Because the battery pack is a heavy element, the deceleration in a crash will create energy displacement at the height of this component. Then the resultant forces from the absorbers have to be aligned with the battery pack for optimal restraint of the force (Figure 48).

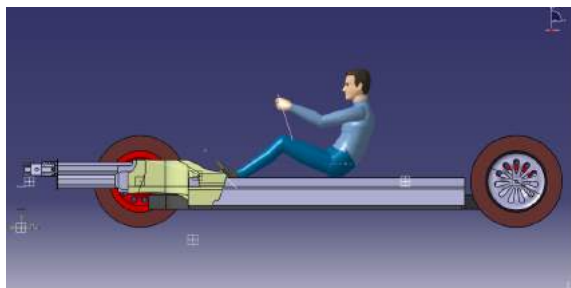

Figure 48. Height difference between the battery pack and the bumper

### Height considerations and load path

According to legal requirements the low speed bumper test meets a barrier that has a height of 408mm to maximum height of 506mm. This is the height of the bumper considered for this concept. The bumper receives the impact and then it is transmitted through the crash box to the free end of the motor rail.

To fulfil vehicle compatibility, the bumper has to receive the force in the legal height. In order to transmit the force to the battery, a structure an inclined connection is needed, where two components are generated,  $F_x$  and  $F_y$ , also the Vector  $F$  and a moment in the join of the floor (Figure 49).

The vector of the Force will be the initial force in  $F$  over the  $\cos$  of the inclination angle.

$$F \frac{F_x}{\cos \alpha}$$

The moment in the join is the initial force in  $X$  times the length of the element.

$$M = F_x \cdot L$$

In order to transmit as much force to the sill, the inclination will be:

$$\alpha = \cos^{-1} \frac{f_x}{F}$$

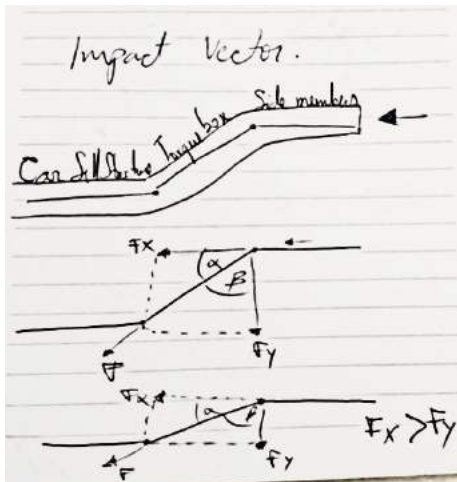

Figure 49. Impact vector and resultants

The angle  $\alpha$  will define the magnitude of  $F_x$  which is transmitted to the sill structure. However, the system is not static, but dynamic, and the sidemembers are intended to absorb energy and redistribute to the monocoque structure.

### Inclined plane

The fork case studied by (Reza, Simkus, 2011) at Chalmers, and also the frontal pole crash show a particular situation where the misalignments of the sidemembers cause intrusions into the peer vehicle. The problem is that the impacting geometry trespass exactly in the middle of both sidemembers, then no energy is absorbed. The proposed solution could be addressed by joining both sidemembers to act together in the crash, so when one is activated, then the other one will activate also, in that way both will deform and absorb energy, minimizing the pulse of the impact. Also the inclined plane will receive the correspondent sidemembers of the other car and absorb the energy of the impact.

As it can be seen on Figure 50 the displacement of the datum on the free edge of the sidemember have decreased, as well as deceleration have increased. This indicates the absorption of energy improved. The connecting sidemembers decrease the directional deformation of the system (Witterman, 1999).

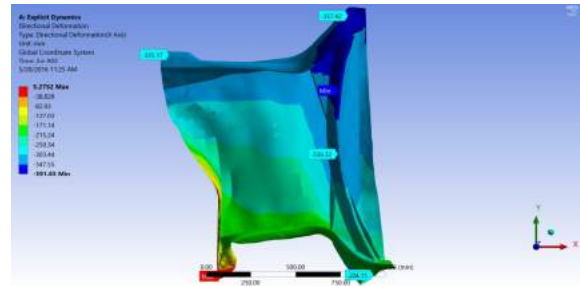
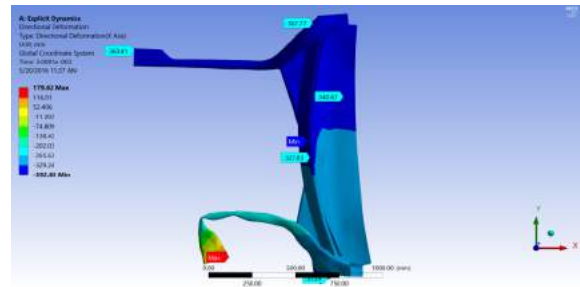

Figure 50. Datum on connecting side members

Directional deformation					
	Probe side rail end	Max	Min	Probe firewall	Probe firewall end
Current side rails	363,41	179,62	392,85	327,83	313,4
Joined side rails	334,94	5,27	391,65	336,32	204,11

Table 9. Probe directional deformation for free sidemembers and connected sidemembers

From the results we can get two conclusions, first the joined structure is stiffer, as the variation of displacement in the firewall probe is smaller for the joined side rails "x'", than the free ends "X"

$$\Delta\gamma = X > x'$$

Then the force absorbed by the displacement can be calculated as follow:

$$F = \frac{\frac{1}{2}mv^2}{s}$$

Where S is the displacement, m is the mass and v is velocity. For this case the probe on the disconnected firewall is used. Mass is assumed to be one unit.

$$F = \frac{\frac{1}{2}m13,3^2}{0,327}$$

$$F = 270,47N$$

When calculating the connecting sidemembers we have:

$$F = \frac{\frac{1}{2}m13,3^2}{0,336}$$

$$F = 263,22N$$

This indicates that the system absorbs less energy in the length displaced.

Second the joining of the two sidemembers makes them work together, as the displacement on the free edge of the sidemember is reduced.

$$\Delta x = X_1 - X_2$$

$$\Delta x = 392,85 - 363,41$$

$$\Delta x = 29,44mm$$

For the displacement in the connected sidemembers:

$$\Delta x = X_1 - X_2$$

$$\Delta x = 391,65 - 363,41$$

$$\Delta x = 56,71mm$$

The difference in displacement for the two designs shows that the connecting sidemembers are effectively constrained by the connecting plate and act together for the energy absorption.

### 3.3 Firewall

Firewall has two main purposes; it serves to protect the passenger's cabin, and is also an integral part of the monocoque structure. It is the barrier between the heat of the motor, the transmission and exhaust and the occupants. In the event of an impact, the thickness of the metal prevents any intrusion from frontal direction or under the car. The inclined plane in the bottom makes the cabin jump over if the motor is detached after a high-speed

crash. As a part of the structure the firewall connects the two motor rails by a mid-cross member connecting the lower A-Pillars. In the upper part is the cowl, which holds the windshield and connects the joining of the lower and upper A-Pillars. In the lower part of the firewall it's the connection with the floor which flows as one piece following the exhaust tunnel or the strengthens along the floor. The firewall has also six torque boxes, three each side, one for the floor, one for the mid cross member and one for the cowl. Those torque boxes balance the momentum generated by the beam properties of the side rails, up rails and the connection between side rails and the sill.

The current project considers the battery pack to be framed between the sills and the firewall. As the battery size determines the power it can store, it would be preferable to have a larger set of batteries for maximise the distance range of the vehicle, this demands more space on the packaging. After the interview at the Volvo BIW department, some of the brainstorm ideas were to move the firewall forward in order to create more room for batteries. However moving the firewall forward would represent a change in the frontal structure, the cross members and the torque boxes.

Firewall is designed to connect the A-Pillars and the floor. It is a barrier between the engine and movable parts and the passengers.

The batteries are constrained by the area under the car. The firewall can be shifted in order to accommodate more batteries in the X direction (Ott, et al. 2014) (Figure 51).



Figure 51. Batteries and firewall

Two design changes are affected by the firewall. First the transmission tunnel would be eliminated, creating a flat floor. This will add structural strength to the floor and to the firewall. The floor will be stiffer for lateral loads, as the tunnel concerns stress accumulation on the edges connecting the floor and the tunnel structure, which is why it demands horizontal cross strengthens (Figure 52).

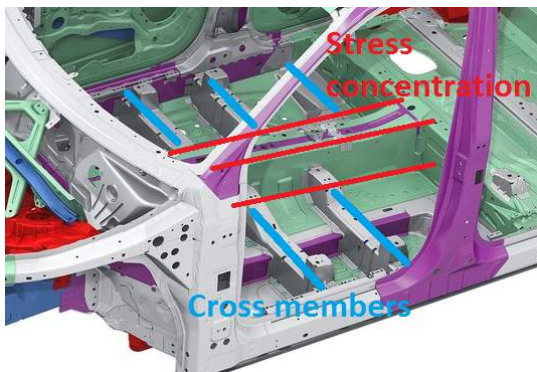

Figure 52. Tunnel in the floor structure and firewall

Second the firewall could be moved forward to create more cabin room. The driver can be moved forward and the rear passenger would have more leg room. As it is shown in the user survey, the internal space is rated as an important factor of the electric vehicle.

A cross member is designed to join both of the torque boxes in the join of the sidemembers. The momentum is generated by the sidemembers which is transmitted directly to the firewall, being the base of the cantilever.

### 3.4 Batteries

The battery is a heavy component of the electric vehicle, representing from 1/4 to 1/3 of the total vehicle mass, depending on the size of the car. If the mass of the battery could be released during the impact, the energy dispersion for the battery should be subtracted from the frontal structure.

The dynamic energy generated by the movement of the free mass of the battery can be compared with the energy generated by the acceleration of both benchmark cars.

In the case of a vehicle travelling at a speed of 48Km/h or 13,3m/s, the results of the dynamic energy are generated as follow.

Tesla

$$E = \frac{1}{2} m \cdot v^2$$

$$E = \frac{1}{2} \cdot 2188 \text{Kg} \cdot (13,3 \text{m} / \text{s})^2$$

$$E = 193,51 \text{KJ}$$

Volvo

$$E = \frac{1}{2} m \cdot v^2$$

$$E = \frac{1}{2} \cdot 2150 \text{Kg} \cdot (13,3 \text{m} / \text{s})^2$$

$$E = 190,15 \text{KJ}$$

Battery

$$E = \frac{1}{2} m \cdot v^2$$

$$E = \frac{1}{2} \cdot 601,36 \text{Kg} \cdot (13,3 \text{m} / \text{s})^2$$

$$E = 53,4 \text{KJ}$$

Energy on impact (wall)

<b>Tesla</b>	193,51KJ
<b>Volvo</b>	190,15KJ
<b>Battery</b>	<b>53,4KJ</b>

Table 10. Energy comparison between benchmark vehicles and battery weight

If the energy can be subtracted from the total energy of the impacting vehicle, then the impulse of the crashing would be minimized. This will represent smaller loads to absorb for the monocoque structure.

## Releasing the batteries

The work done on an object is equal to the change in energy. The car can be pictured as structure with a spring in the front, and then the work acting on the front will be zero, because there is no work done to the spring during collision. This is because the kinetic energy decrease to zero and the potential energy increment on the spring equal to the kinetic energy, balancing the system (Figure 53).

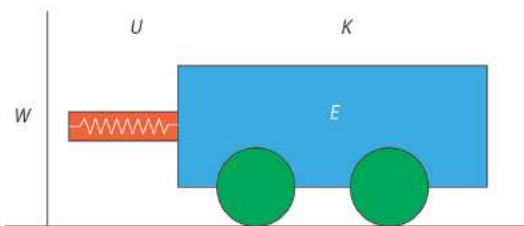

Figure 53. Car energy diagram

$$W = 0 = \Delta K + \Delta U_s$$

$$W = K_2 - K_1 = U_2 - U_1$$

Position 1 is before the impact and position 2 is when the car stops. Then  $K_2$  is zero because the car is stopped and  $U_1$  is zero because the spring is uncompressed before impact. Then the work would be:

$$W = K_1 = U_2$$

The dynamic energy of the impact is stated above, and the potential energy of the spring is

$$U = \frac{1}{2} \cdot k \cdot s^2$$

Being  $k$  a spring constant, and  $s$  the distance the spring is compressed.

$$W = \frac{1}{2} \cdot m \cdot v^2 - \frac{1}{2} \cdot k \cdot s^2$$

The total energy of the vehicle is the mass times the velocity square, then the mass of the vehicle would be.

$$E = \frac{1}{2} \cdot m \cdot v^2$$

$$m = \frac{2E}{v^2}$$

Assuming the battery is released as a free body and the spring of the battery would compress completely and absorb the kinetic energy during the impact then we have that the total energy of the car would be (Figure 54):

$$E_t = E_1 + E_2$$

$$E_2 = 140,11KJ$$

To compare the complete car and the car with no battery we have the car 1 and car 2. Assuming that the distance of the compressed spring is the same, it is possible to get a comparison of the stiffness of the  $k$ ; a higher value means a stiffer spring.

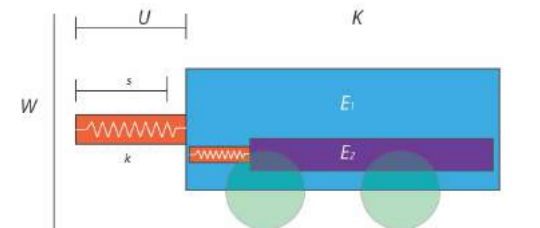

Figure 54. Car energy diagram with battery release

$$W_1 = 0 = E_t - \frac{1}{2} \cdot k \cdot s^2$$

$$E_t = -\frac{1}{2} \cdot k \cdot s^2$$

$$k_1 = \frac{2E_t}{s^2}$$

For the car with battery released

$$k_2 = \frac{2E_2}{s^2}$$

Assuming the displacement  $s$  is a unit (1). Then the difference would be

$$k_1 = \frac{2 \cdot (193,51)}{s^2}$$

$$k_1 = 387,02$$

For the second  $k$

$$k_2 = \frac{2 \cdot (140,11)}{s^2}$$

$$k_2 = 280,22$$

This indicates that a solution absorbing the energy of the battery would demand a less stiff spring, and decrease the kinetic energy absorbed in the impact. In a real case the crumpling zone of the car is way more complex than a spring, but it behaves in the same way absorbing energy.

However, releasing of the battery as a free body presents the problem of how to manage the kinetic energy of the accelerated battery. A second problem is how to restrain the battery body from free displacement after the impact.

## Impact absorber

Aluminum honeycomb crush pieces are located in the front of the battery, using the stiff frame of the floor as the support. The battery is released in an impact and it will travel forward crushing the honeycomb and decreasing the kinetic energy as the honeycomb is compressed (Figure 55).

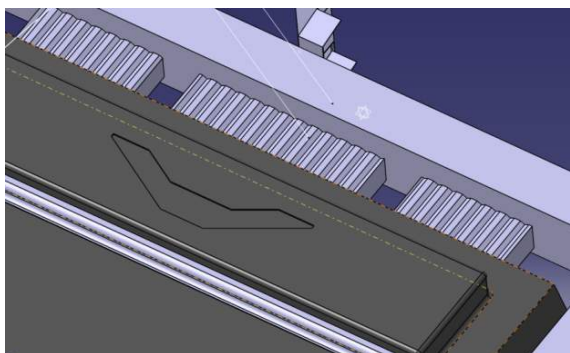

Figure 55. Aluminum honeycomb impact absorber

## Brackets

The battery package is intended to move forwards during an impact. The displacement is controlled by deformable brackets alongside the pack. The brackets can withstand the normal load of the road and vehicle dynamics, as well as forward, braking and lateral loads. However they are designed to collapse in the event of an impact. In this solution the battery is hold by the brackets all the time and the collapsing is triggered by the kinetic energy. It is initiated when the deceleration of the body reach a point for the stress on the bracket to exceed the design failure criteria (Figure 56).

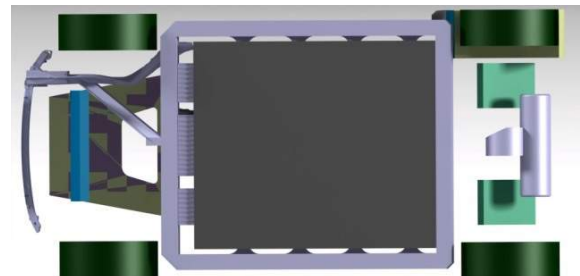

Figure 56. Deformable brackets

## Pyro nuts

The battery is attached to the sill structure by brackets fastened with pyro nuts which explode before the impact to release the battery and let the mass act as a free body when crashing. The advantage is that the firewall cross member will deform to absorb the energy, then the size of the battery pack can be increased because the movement does not need any extra room. The bottom of the firewall has a deformable cross member which receive the traveling battery and deforms to absorb the energy (Figure 57).

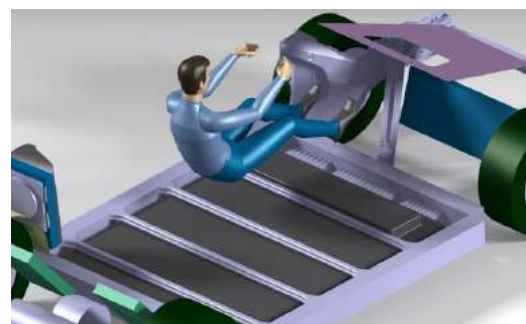

Figure 57. Pyro nuts battery release

### 3.5 Hood

#### Recurrent use

According to the user study, the frontal storage space is rather misused. Even more, the main use of the frontal space is to store car-related accessories for maintenance, most of them not vital in any way for the correct function of the vehicle, with the charger exception. According to the user study survey, just 12,76% of population frequently use the frontal luggage storage space as a main storage.

#### Hood structure

On the other hand, more and more the components under the hood are less accessible to the user. In modern electric vehicles the only interaction with the user is the windshield fluid tap. Currently the hood is detachable and even when it is designed in a structural way, it absorbs little or no loads during an impact. The design is intended mainly to make it stiff enough for vehicle dynamics, to balance the vertical and lateral loads that come from the suspension struts and upper rails. In the event of a crash the hood deforms as it is designed, mainly to avoid intrusion inside the cabin through the windshield (Witowski, 2014). However, if the hood is incorporated as integral part of the monocoque the load of the impact could be distributed in a bigger area before impacting the cabin, alleviating the load on the A-Pillar and absorbing energy combined with the sidemembers. This solution contemplates the advantages of joining the sidemembers with an included plane and then joining the hood as part of the monocoque. By bonding this structural elements a kind of “*Can structure*” starts to take form, which could be developed as a concept to carry on the project.

### 3.6 Closed structure

#### Everything working together

At this point many aspects of the design have been analyzed and evaluated. Using the investigation of (Christiansen and Bastien, 2015). The closed structure concept was defined. First, the sidemembers transmit the load to the floor and to the sill. Second there has been suggested to create an inclined plane connecting both members, which add stiffness to the structure and permit both of them to work together absorbing energy on the case of horizontal misalignment. Third, the hood is considered part of the integral structure connecting both sidemembers by the top, but also connecting the A-Pillar and the cowl with the firewall. The next iteration will join those three elements together, to make it work as one structure.

#### Features

A closed structure covers a bigger area of impact, interacting with every element of the frontal structure. It is not intrusive because there are not beams in cantilever and also alleviate the load to the A-Pillar by deriving the load paths to the floor (Figure 58). From a manufacturing point of view assembling the vehicle is possible without a hood opening, because in electric cars the hood is never used to assembly major components, because in the assembly line the monocoque meets the powertrain and welds it together from the top.

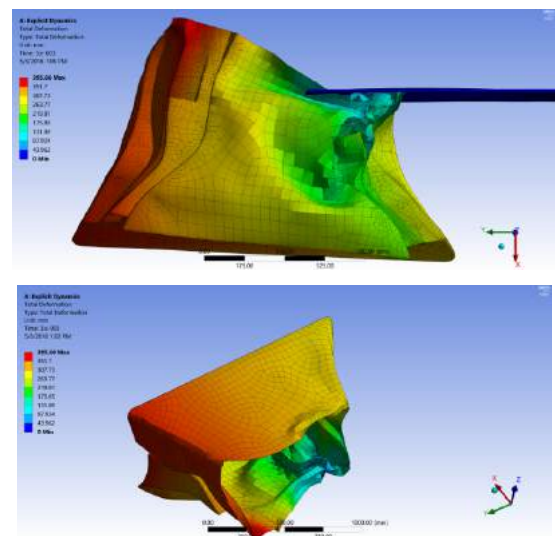

Figure 58. Frontal architecture working as an integral structure



### 3.7 Tire envelope and suspension

In order to change the frontal architecture it is necessary to look at the major parts and systems and fit the components in a reduced packaging. The concept of the closed structure pretends to bond the sidemembers, hood and front floor together, as well as reducing the height of the front structure as much as it is possible beneath the margins of the legal requirements like the bumper dimensions and height. By analyzing the car base Volvo S90, it is noticeable that the suspension system occupies a large space of the vertical area of the frontal structure (Figure 59). This height difference is a consequence of the suspension geometry as well as the suspension strut. The project aims to have an EV concept with a low aerodynamic drag coefficient. For this an aerodynamic body work should be considered with a low stagnation line. Therefore the frontal structure should be able to accommodate the suspension in a lower position.

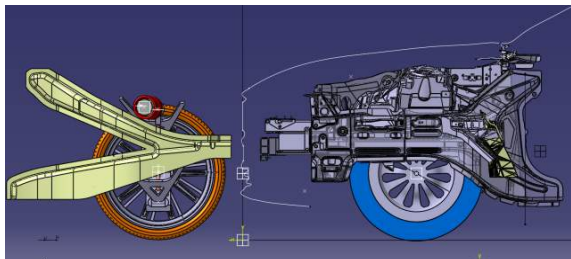

Figure 59. Frontal volume comparison

In order to achieve this goal, the suspension of the vehicle has been re-thought. The solution proposed is a horizontal double wishbone suspension. The independent suspension would be mounted on the closed frontal structure by parallel wishbone arms. The concept use horizontal dampers with rockers and pushrod for the suspension (Figure 60).

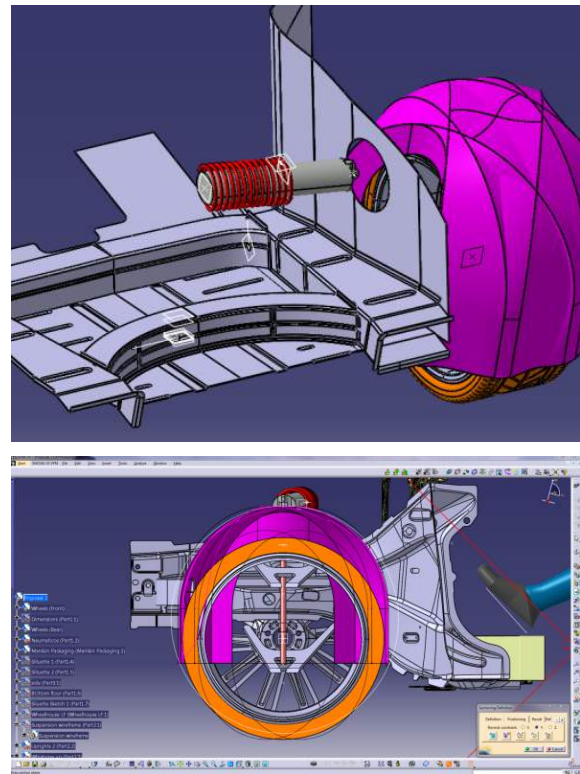

Figure 60. Tire envelope and horizontal suspension

All the elements next to the tires have to go around the tire envelope. In the case of the suspension, the proposal considered that the suspension do not interfere with the turning angles and translation of the envelope. On the other hand, the wheelhouse is modelled to be structural part of the sidemembers. The upper part of the wheelhouse is a barrier for the tire and also acts like an integral part of the closed can, completing the whole structure.

### 3.8 Cooling

Current electric vehicles needs cooling for the battery pack and for the electric motors. However the current solutions still use the IC layout for the cooling package, which is to place the radiator before the bumper between the cashbox (Figure 61).

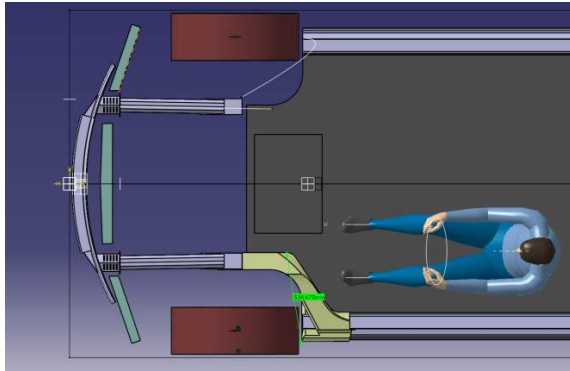

Figure 61. Cooling pack positioning on the Tesla model S

The low speed crash test evaluates the bumper and how well the crash box dissipates the energy with a minimal damage to front structure. The insurance companies have strict policies about the damage that a car suffer on impact, and the deductibles the owner has to pay. In general terms IIHS evaluate the ability of the car to receive a low speed impact with a minimal monetary damage. The thinking behind this test is: the cheaper it is to repair the car after crash, then the better rating in the evaluation. On the other hand, the cooling pack is arguably the most expensive part located in the foremost part of the vehicle. It is a rather complicate and fragile system which can be highly damaged after an impact, raising the costs of reparation and lowering the IIHS rating. It is comprensible that the cooling package is located close to the engine in IC vehicles to cool the engine efficiently with the shortest distance possible. However, for EV the packaging conditions are different. The two main components to be get cooling are the electric motor and the battery pack. For this project concept the electric motor is considered to be located in the rear part of the vehicle, then it would be needed large hoses and a pump in order to get the coolant from radiator to

the motor due to distance. The battery also needs cooling, and it is located in the middle section of the car, demanding the same need for hose and pump. Moreover, regarding the location, as the air pressure is higher in the front of the car it is logical to place the radiators in that area, however, as the engine bay structure is modified in this project, more options are available for the concept.

### Cooling pack after crash box

A big problem with low speed crash is the damage produced to the radiators and cooling package in general. This is because the crash boxes are designed to collapse, displacing the bumper and affecting the cooling pack. As the crumpling zone structure needs this kind of displacement, the solution is to move the cooling behind the crash boxes, where the pack is protected from small bumps by the sidemembers stiffer structure (Figure 62).

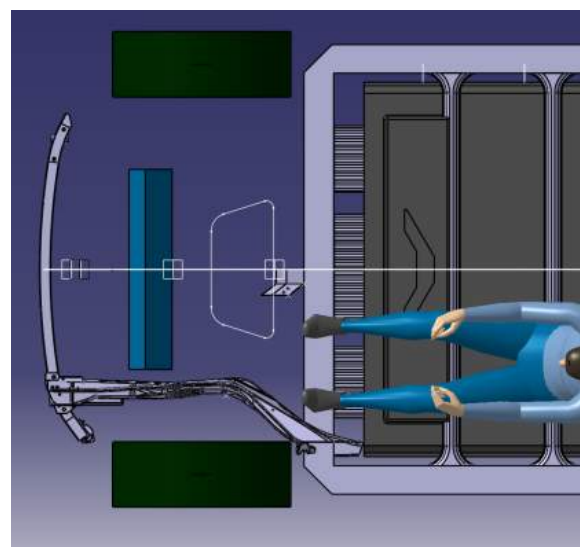
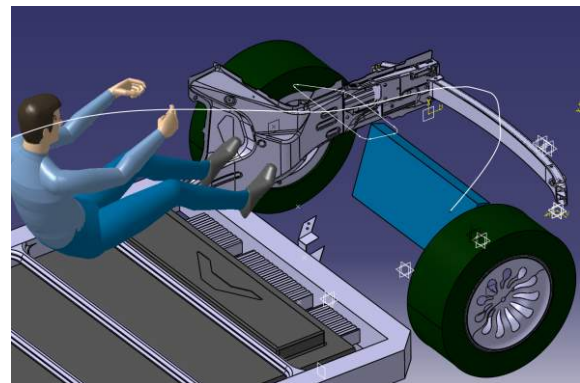

Figure 62. Cooling pack between the sidemembers

## Cooling pack on the rear

The rear motor needs cooling, however, the piping from the frontal radiator is large. A solution is to allocate cooling packs in front of the rear wheels. Using side ducts to drive the air from the side of the car to the radiator and use the wheelhouse as the outlet for the system. The advantage of this solution is the proximity of the motor and the cooling (Figure 63).

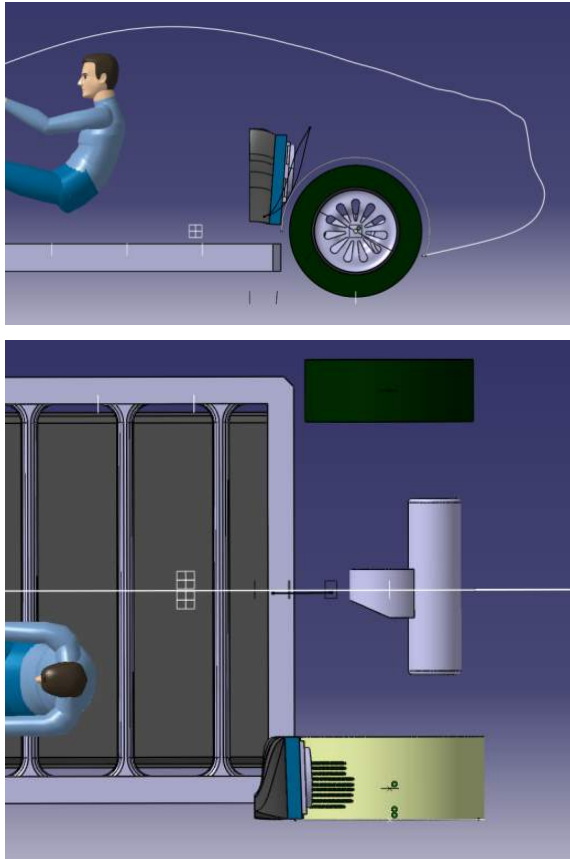

Figure 63. Rear cooling pack

## Air cooling for batteries

The BIW use hollow sections for the monocoque structure, formed after welding two pressed sheetmetal borders. The sidemembers travel across the car from front to rear, through the floor and the sills. Those hollow spaces are lost from a packaging perspective, because no component or element is located there. However, from a cooling perspective, these hollow spaces can be used as hollow pipes, carrying cool air from the front and be delivered to the battery pack for cooling.

## 3.9 Ergonomics

The packaging of the car is indisputably designed around the driver. The passengers are the most critical component of the vehicle and the entire architecture is created to protect them and provide the space they need. The position of the driver and passengers is extremely important because it sets the dimensions of the cabin. In an ideal situation the design of the car will be made from inside-out, meaning that the center of the design are the occupants. To create the driver positioning it was used the SAE 95th percentile male manikin, which is one of the most used packaging tools for ergonomics. The most important point to set the position is the Seating Reference Point (SgRP) or the Hip Point (H-Point) as known in US (Macey, 2014). The manikin is used to set the mobility, the proportions and the dimensions inside the cabin. It is used to determine the volume occupants need to control the vehicle or to sit as passengers. In order to encompass the majority of the population it has been set in the (SAE handbook, 1996), that the vehicles should allocate comfortably a manikin from 5th percentile female to 95th percentile male. This percentiles include 97,5% of the population as shown in (Figure 64).

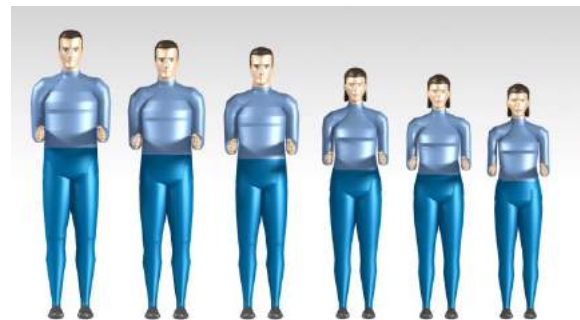

Figure 64. 95th percentile male to 5th percentile female

The most important part of the manikin is the H-Point, which set the lower limbs and upper body angles and dimensions. The lower limbs are measured from the H-Point to the feet, so it can set the seat height and the room for the legs. From the H-Point to the head it sets the cabin height. It is important to mark that if the H-Point is moved the entire vehicle is affected, because many parts interact directly with the position of the driver. In this project, the ergonomics rely on the Volvo S90 as

car base, because the vehicle has been designed and engineered with ergonomics vision. Then the manikins were located as they were in the car base, (Figure 65).

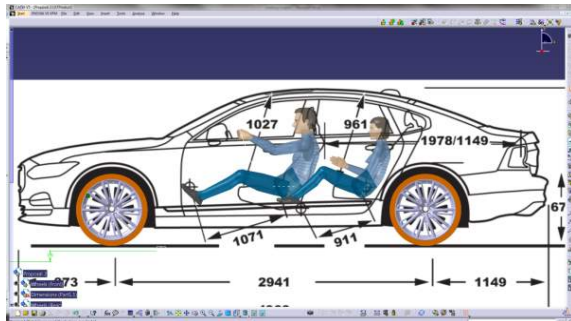

Figure 65. Ergonomic points in the Volvo S90

## Visibility

The visibility is set by the angles over and below of the horizontal axis from the eyes of the driver. Those angles are called A60 for over, and A61 for the angle below. The angles have to clear the windshield with no obstruction for the driver, and then the position is set. The recommended upper angle for traffic light visibility is 14 degrees, with a minimum up angle of 7 degrees. The lower angle is minimum 4 degrees. This will provide a clear visibility of the road, lights and traffic. As it can be seen on Figure 66, the visibility of the project is set to 15 degrees for upper angle and 5,5 degrees for the lower angle of visibility.

## Passenger

The passengers have a different posture than the driver, the knee angle is lower and the feet lay flat over the floor instead of with an angle. The space between the SgRP is called couple and varies from vehicles depending on the segment. In the S90 the couple is 820. Other characteristics of the rear seat are that the upper body dimension does not include a travel for the head, as the rear seat does not move forward.

## Room

Usually for large sedan cars the headroom would be 985mm, in the S90 is 961mm, this creates a cabin a little tight for the 95th percentile manikin. As the car increase dimensions the headroom goes higher, but just up to a certain point, because higher roof would increase drag and raise the CoG. In the previous segment it was suggested that the firewall could be moved forward in order to create more space for the batteries and create more interior room for passengers. In order to maintain good ergonomics on the concept some of the dimensions of the S90 were taken and others were kept as dictated on the literature. The list of the ergonomic values of the EV Concept is as follow.

Driver and front passenger						Rear occupants		
Heel to ground	H-Point to ground	Back angle	Head room	Upward vision angle	Downward vision angle	Couple	Chair height	Effective head room
275	520	24.0	975	15	5,5	920	275	975

Figure 66. Ergonomic dimensions for the concept

### 3.10 Segment

Every car is manufactured with the aim to fit a certain segment. This is a group of characteristics that define the function and utility of the car. The designed vehicle should be located in the concept of the market that it is going to be sold, among other competitors and alongside other vehicles of the same manufacturer. In this project the EV Concept is compared with current production Volvo cars which go with the line of the SPA. According to this project survey, the majority of people prefer the electric vehicles to be a rather compact or economy car. However some characteristics like sporty and luxury are also desired.

#### Compact segment

In order to understand where to set the electric vehicle among the segment, a user surgery was done. Among people from different ages, educational background and sex. The results show that the majority (93%) prefer a car that fit in the compact or economy segment, covering from the 50th percentile to the 99th percentile of the survey.

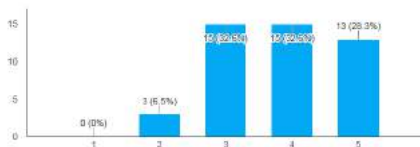

#### Sport segment

However, as the survey considered different segments, the users rated the conception of electric vehicles in different segments. The sport segment received votes among the medium important (35,6%) to some important (33,3%). This number sum up 68,9% of the interviews considering the EV to fit into the sports characteristics. It is noticeable that only (4,4%) considered the sport segment to be very important.

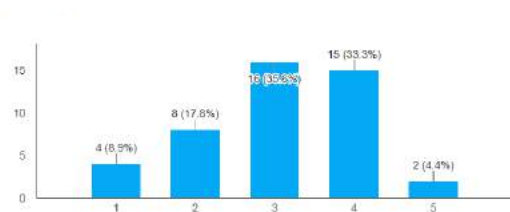

#### Luxury segment

The luxury segment obtained the most divided opinions. With (2,2%) voting for not important at all, and (6,7%) voting for very important, this segment has not favourites in the poles. It is noticeable that almost half of the interviewees (46,7%) voted for a medium important characteristics for the EV. As a conclusion the luxury details on the car are not extremely important, but the user demands some hints in that direction also.

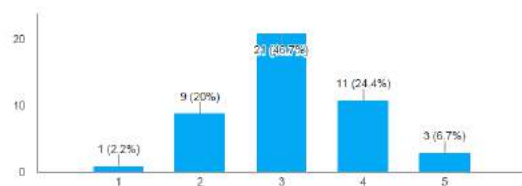

# Segment positioning

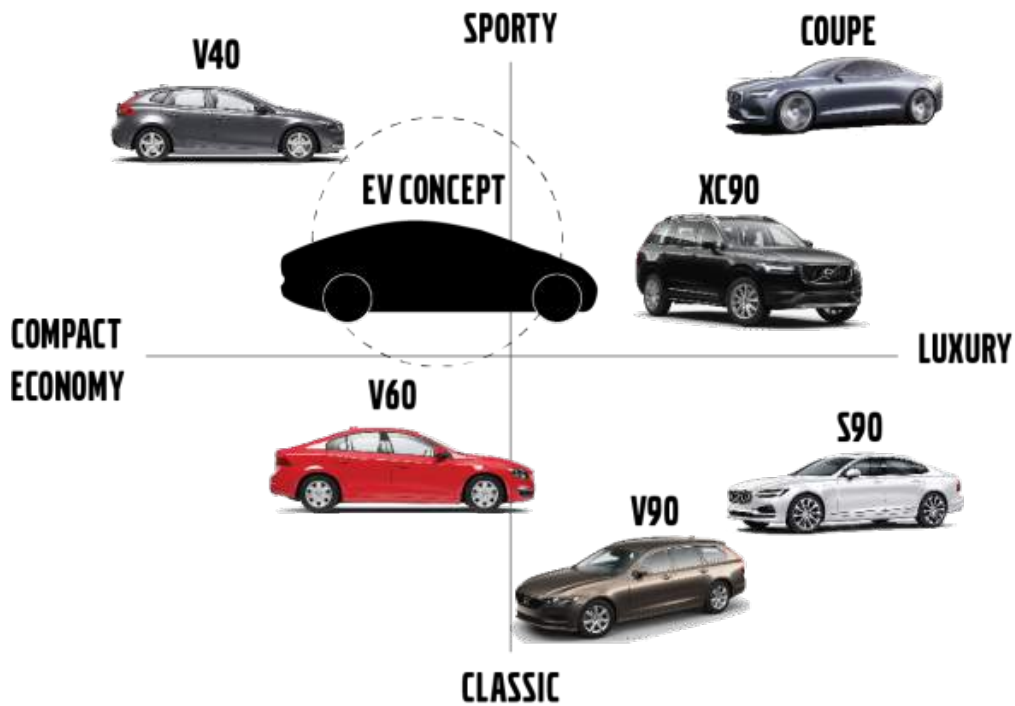

Figure 67. EV Concept in the Volvo segment context

The development of the vehicle positioning graph allows visualizing the market niche, where the EV Concept fit among other electrical options. It shows the opportunity to develop a vehicle in a segment

where no other car is placed. Presenting a good opportunity for investment and development (Figure 67).

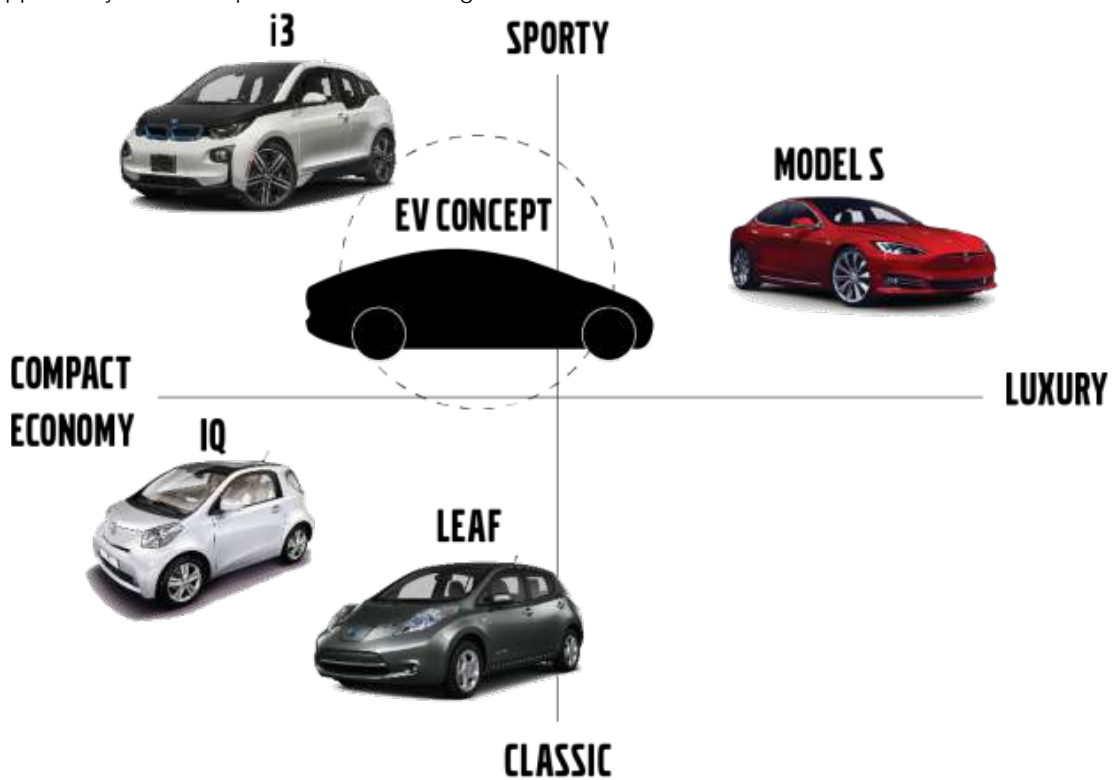

Figure 68. EV Concept in the competitor segment context

The analysis shows that the EV Concept can fill an empty space in the current market. Also shows that the empty space corresponds to the desires of the survey people regarding electric vehicles. The concept don't overlap other similar EV vehicles neither other vehicles of the same brand, then a concept with those characteristics is possible.

### 3.11 Brand identity

The selection for the design form analysis (DFA) was done based on two main aspects. First the cars should be a current model on the Volvo line, or the direction Volvo is taking for future models, in order to keep the concept updated in line with the current development. Second the cars belong to the segment analysis in order to take broad samples and create a concept that fit the entire Volvo line.

The analyzed features were the most significant for each product and were selected by the visual approach of the vehicles. The main characteristics and the repetition on elements were considered as more weighted in order to get broader values (Figure 69).









									
	S90	XC90	V90	Coupe Concept	State Concept	XC Concept	V40	V60	
Headlights T-Light	•	•	•	•	•	•			6
Tail lights C-Shape	•	•	•	•	•	•		•	7
Front grill stripes	•	•	•	•	•	•	○		6
Side mirrors			○	•	•	•	•		4
Emblem	•	•	•	•	•	•	•	•	8
Cat walk	•	•		•		•			4
Front air intake	•	•		•				○	3
Inclined shoulder		○	○				•	•	2
Straight hood	•	•		•	•		○		4
	14	15	10	16	12	12	8	7	

Figure 69. Design form analysis of Volvo brand

#### Explicit design cues

The most rated feature on the current Volvo line of cars was the emblem, then the front grill stripes and then the tail C-shape lights as well as the front headlights featuring the *Thor hammer* styled *T* light. Those are shared characteristics with a strong visual

value that can be easily recognized among the vehicles. The strong lines of the front grill give the car a distinctive look and elegant shape. The vertical bars contrast with the horizontal perimeter of the front structure. The metallic material differentiates

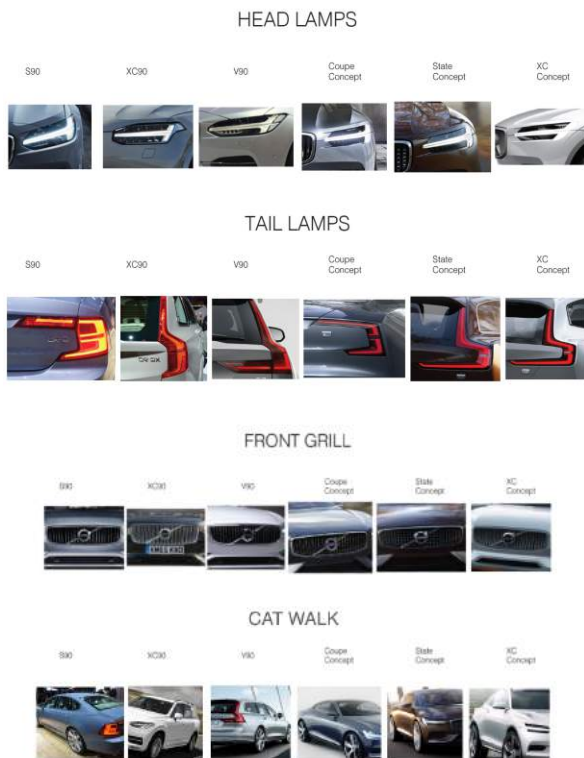

Figure 70. Explicit Volvo design cues

### 3.12 Expression board

In order to create a concept it was necessary to understand first what kind of vehicle the thesis was aiming for. So the expression board show the main characteristics the EV should have (Figure 71).

Safe as the crashworthiness characteristics of the vehicle, preserving human life and taking the right steps in order to maintain good standard of safety in the vehicles.

Reliable as the materials used in the construction of the car, the engineering features and the calculations. It is important to know that the vehicle will not fail at any point and that the structure can stand the regular and not so regular use of the vehicle.

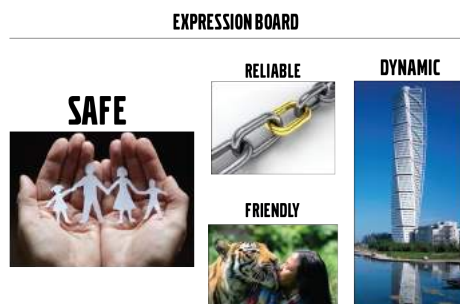

Figure 71. Expression board for EV

from the black background and appears as a subtraction of the volume. This effect dramatizes the circular emblem located in the center which pops up in the vision field (Figure 70).

These main characteristics are applied to the concept in order to look for the shape and forms that communicate the identity of a Volvo. The design cues are combined with the demands for electric vehicles to drive the ideas behind the EV concept.

Dynamic as the elegant and sporty segment that the user survey suggested. At the same time the dynamic of the exterior is directly related to the aerodynamics of the car.

Friendly, as the interaction with the user. Comfortable, with good space for legs and passenger, as well as good accessibility.

### The not desired board

As it is important to understand what the project wants to achieve, and it is equally important to understand what not to come with during the development of the concept (Figure 72).

The project is not pursuing an unrealistic concept, with futuristic forms and exotic looks. The thesis is based on a real car and pretends to come with solutions that can be optimised and considered to future application.

As the car base has been set from the beginning of the project, the idea of a micro car has been detached also. The car base, as well as the benchmark car are big sedans, setting the bar for an EV of similar characteristics.



Figure 72. The not desired board



### 3.13 Synergy process and filtering

The funnel model filter the solutions appreciated in this chapter by listing them and evaluating the solution through three different gates. The solution that cope with the requirements pass through the funnel and get to the next step. There are three main evaluation points that the weighted solutions have to cope. Those gates are, first the crashworthiness requirements, second the neighbouring demands that come from the interaction between one or more components affected by the solutions, and third the criteria of *concept unity*, which evaluate the compromises among the solutions and procurees to create a solid concept (Figure 73).

The listed solutions developed in this chapter are as follows.

- A. Beam support
- B. Frame structure
- C. Diagonal crossmember
- D. Torque boxes to floor
- E. Connecting side members
- F. Firewall movement
- G. Battery impact absorber
- H. Battery deformable brackets
- I. Battery pyro nuts
- J. Hood as a structural part of the BIW
- K. Closed structure
- L. Horizontal suspension
- M. Cooling package
- N. Ergonomics
- O. Segment

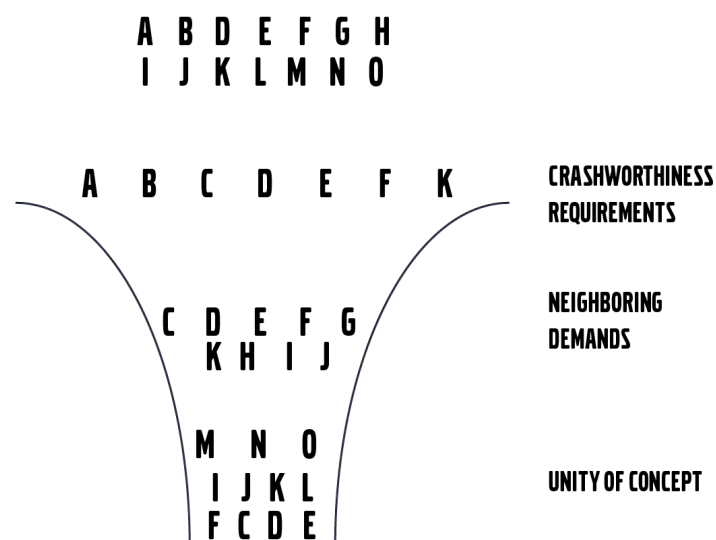

Figure 73. Solution filtering, gates method and process

From the evaluation the selected solutions that cope with all the gates were.

- C. Diagonal crossmember
- D. Torque boxes to floor
- E. Connecting side members
- F. Firewall movement
- I. Battery pyro nuts
- J. Hood as structural part of the BIW
- K. Closed structure
- L. Horizontal suspension

- M. Cooling package
- N. Ergonomics
- O. Segment

These individual solutions got a good rate of crashworthiness criteria and show positive interaction among them.

## 4. CONCEPT

This chapter describes the Electric Vehicle Concept as an integral solution, explaining the details of the proposed ideas and portraying the unity of the concept.

# FINAL CONCEPT

The body in white architecture with the electric vehicle in mind

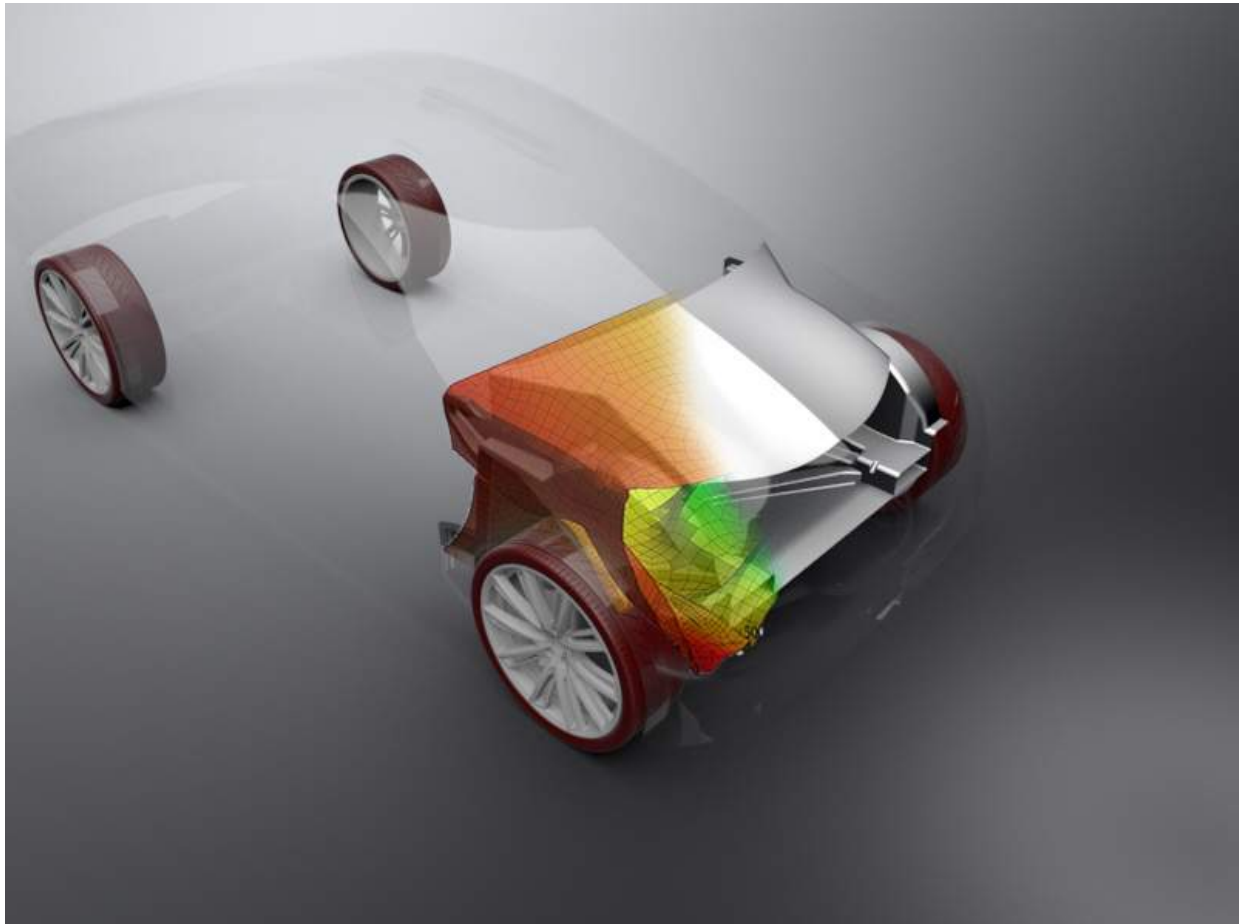

*Figure 74. EV Concept*

The final concept of this project is the synergy of the components of the functional model. Every element has particular requirements and the design of those requirements places additional demanding on the neighbouring components. The system is based on the elements working together as a unit to fulfil the crashworthiness criteria and the design style.

## Safety

Crashworthiness is the main priority for the project because the ultimate goal is to provide a product which is able to protect and preserve life. The main attention of the project has been the safety for the

passengers. Different crash cases were analyzed to get a broader understanding of the effects of the impacts on electric vehicles.

## Multi functional

SPA is the key for the present and nearly future at Volvo. It is adaptable for big and small cars, it is highly customizable and suits different segments of the market. The proposed concept is developed to fit the SPA as the core of the EV architecture, by using dimensions as part of the structure from the A-Pillar, roof and floor to the rear of the car.

## Proposal

### 4.1 Body in White

The electric vehicle is tested as a regular car and has to pass the crash tests in order to be a safe vehicle. As the EV has a different layout of components and packaging the needs for the load distribution change. Figure 75 show the BIW proposal of the EV Concept. It is based on the traditional architecture of cars, using same manufacturing techniques, joining the parts together using spot welding. It is important to notice that the design has been developed with production in mind, modelling the surfaces and parts according to sheet metal stamping. This created a modular architecture where all the pieces fit together like a puzzle.

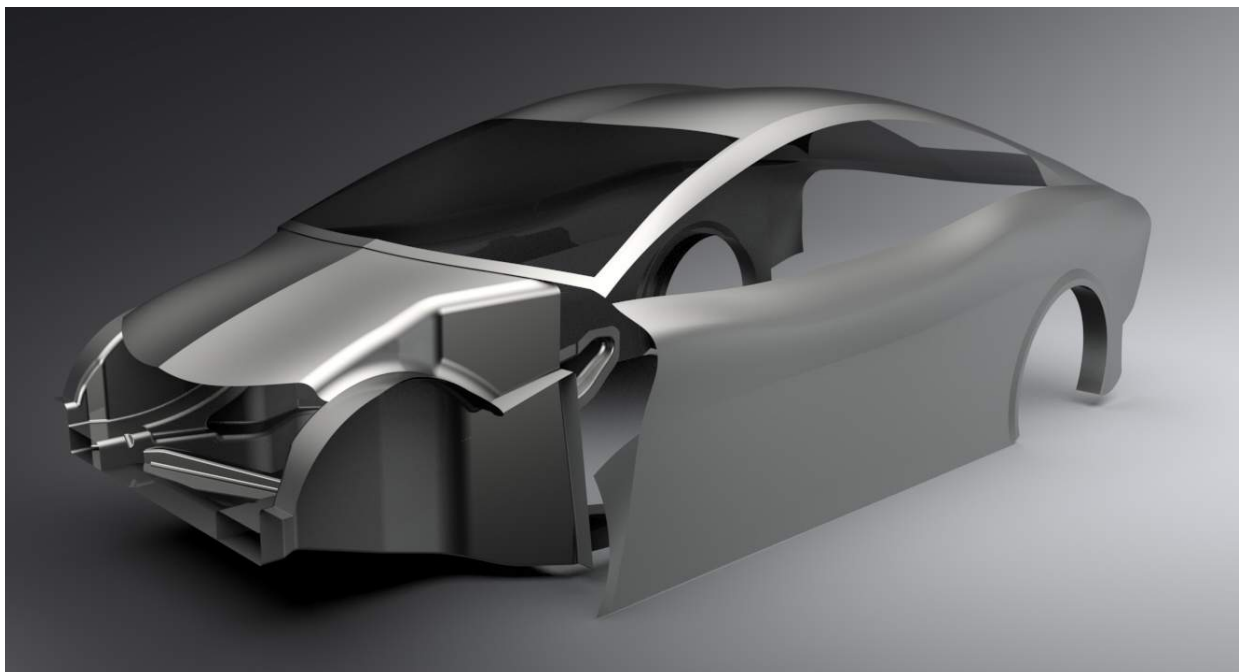

Figure 75. Body in white proposal for the EV Concept

### 4.3 Connecting sidemembers

Sidemembers are connected by an inclined plane made of sheet steel. The loads are distributed to increase the stiffness of the frontal structure and better handle complicated load cases, like the misalignment of two vehicles or a frontal pole crash. The connecting members can interact between each other and they activate at the same time in a collision (Figure 76).



Figure 76. Connecting sidemembers

The sidemembers are accommodated in a horizontal position, with the minimum moment of inertia in the Z-Axis, this will stiffen the structure in the Y direction and prioritize the load carrying to the sill structure. This arrangement has two major advantages. First, as the sidemembers are placed horizontally the bending direction for energy absorption will be along the Y-Axis, bending the sidemembers in a shape of “N” after the crash. The elements collapse vertically, maximizing the space reduction of the overhang (Figure 77).

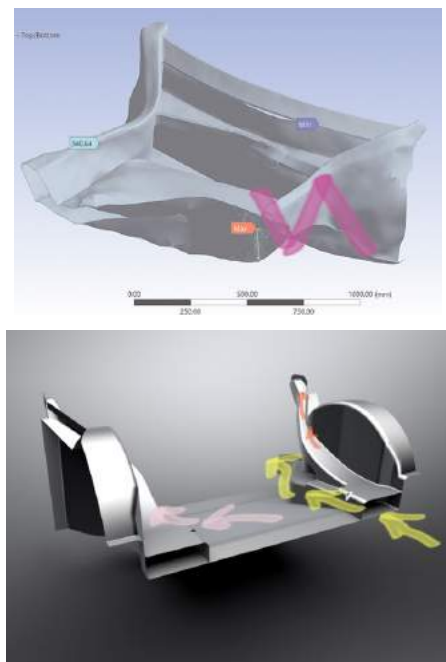

Figure 77. Deformation and load paths on the connecting members

Second, the loads that haven't been absorbed by the crumple zone are mostly managed by the floor, which has a reinforced structure to hold and protect the battery pack. The sidemembers split in two arms which connect to the A-Pillar in two different points. The lower arm directs the force to the sill, the second arm is thinner and carries less loads. The intention is to alleviate the point on the A-Pillar where the sidemembers, the cowl, the shotguns and the hood meets. All those loads are traditionally managed by the upper A-Pillar and the roof structure, which is a less stiff structure than the floor.

#### 4.4 Angled crossmember

Small overlap is a complex test that demands the boundaries of the car to bear large loads. The approach to this problem is to shift the vehicle in the Y direction before impacting the A-Pillar. When the vehicle impacts the barrier the bumper is bent to inside the car, hitting the horizontal sidemember which can better stand loads in Y direction because of the larger moment of inertia. As the car is traveling towards the X direction the impact is a diagonal resultant. The angled crossmember mounted on the inclined connecting plane is geometrically opposite to the resultant. The angled crossmember takes the loads in two directions and derives the loads to the A-Pillar and to the firewall crossmember, which is part of the stiffer floor structure (Figure 78).



Figure 78. Angled crossmember

#### 4.5 Air cooling for battery

Currently cooling fluid is used to keep the battery pack cool. On the other hand, the sidemembers occupy some volume that is inaccessible to any function and can be considered loosen space. The

sidemembers are metal sheets which can be sealed and act like cooling ducts. The sidemembers which goes directly to the floor structure carry the accelerated air through the structure and then it is spread through cooling plates to the battery pack (Figure 79).

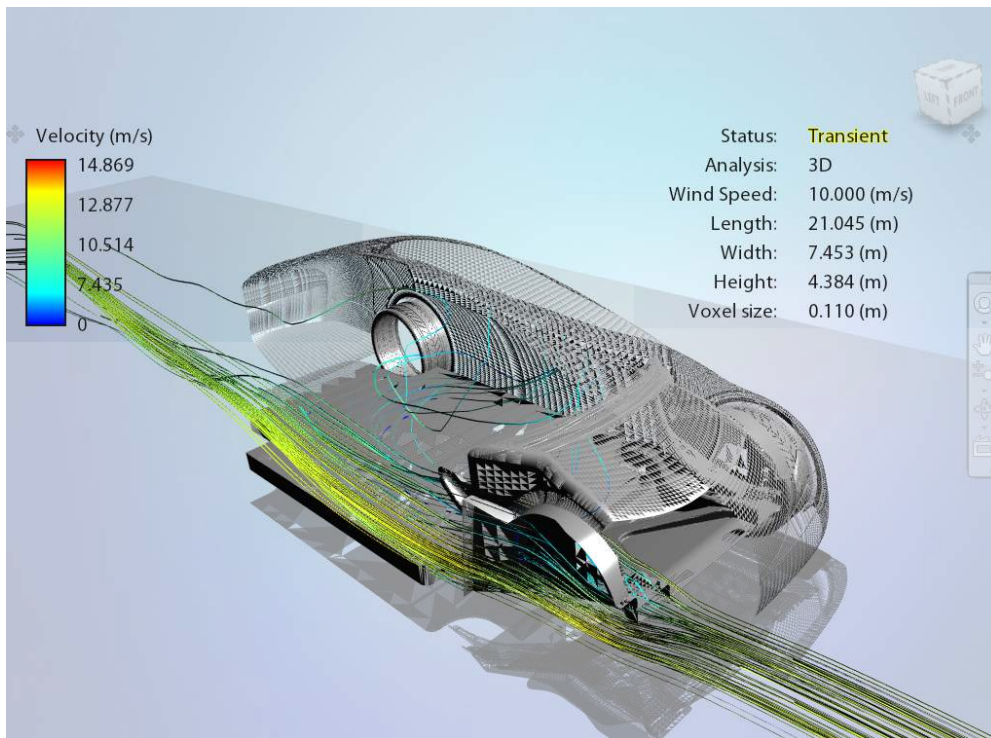

Figure 79. Air cooling for the battery

## 4.6 Battery brackets with pyro nuts

In the event of a crash the battery pack is released to subtract that mass out of the car weight during impact. Then decreasing the kinetic energy to be absorbed by the structure of the car and creating a safer vehicle. The battery pack is mounted on

deformable brackets in order to contain the dynamic energy that the battery has because of the acceleration. The brackets are activated passively when the deceleration peaks the failure point of the bracket. Pyro nuts are used to explode milliseconds before the impact in order to release the battery to pull the brackets (Figure 80).

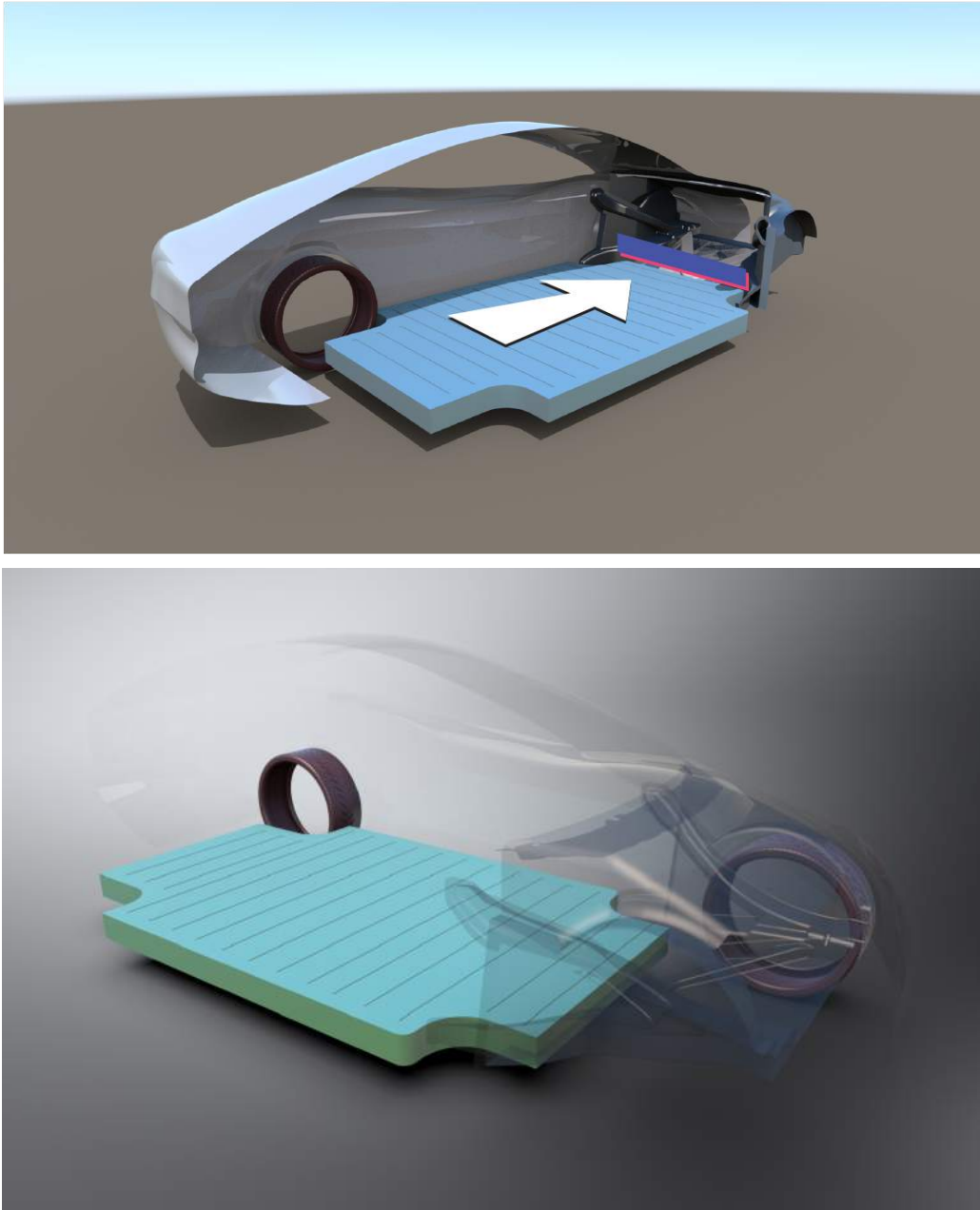

Figure 80. Battery as a free weight

## 4.7 Accesibility

The sill structure is reinforced to accommodate the batteries safely. However as seen on the Tesla benchmark car, this creates large cross sections to withstand the stiffness of the entire monocoque in the floor area. A large sill creates some uncomfortable openings for the car's doors, because it is high and wide, then the person has to largely extend his legs in order to get inside the cabin (Figure 81). To address this situation two solutions were created. The doors are going to open like gull wings, with a hinge in the roof, allowing more space

when open. The reinforced floor and larger sill cross sections creates a "U" shape in the cross section of the car. The U shape has higher sills and lower floor. To ensure the easiness of access to the driver and the passenger, once the gullwing doors are open the seat will turn 90 degrees facing outwards for the person to sit and get turned back to the driving position. The seat also elevates in order to minimize the gap of the sill and the floor, so the person has to incline less in order to get inside the car.

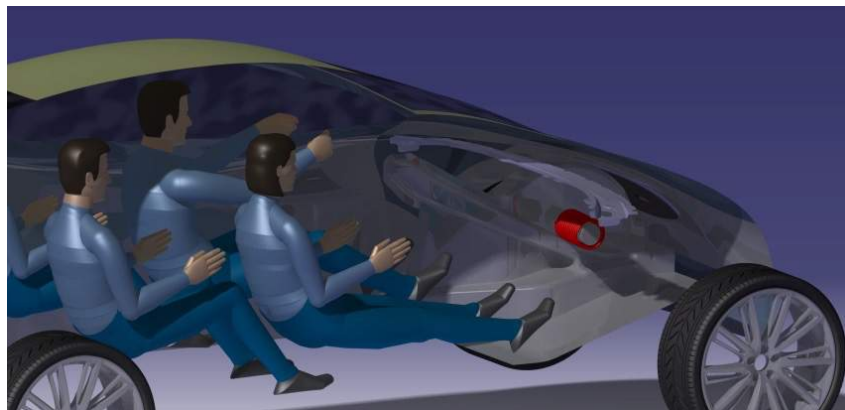

Figure 81. Ergonomics and accessibility

## 4.8 Body work and design

Historically one of the biggest identifiers of Volvo has been the line going along the side from forward to the back of the vehicle. The new external architecture of Volvo relies very much on the forms of the grill, being a heavy element in the composition.

As well as the front headlights, shaped with a distinctive T shape, also known as Thor hammer. On the rear the C-Tial lights characterize the design to bring the concept a Volvo feeling. All this elements were considered in order to create a shape that has the identity of Volvo in the forms (Figure 82).





Figure 82. EV Concept, the Volvo feeling

#### 4.9 A note on aerodynamics

The EV Concept has been conceived as a car for the electric future. The changes in the frontal structure set a base to change the design of the external geometry. The reduced overhang and the lowered

hood created a car with a very low frontal pressure area, only 54Pa at 10m/s. Due to the streamline design of the vehicle profile, the velocity of the air is very constant over the surface. The stagnation line starts very low due to the frontal profile that creates an early division (Figure 83).

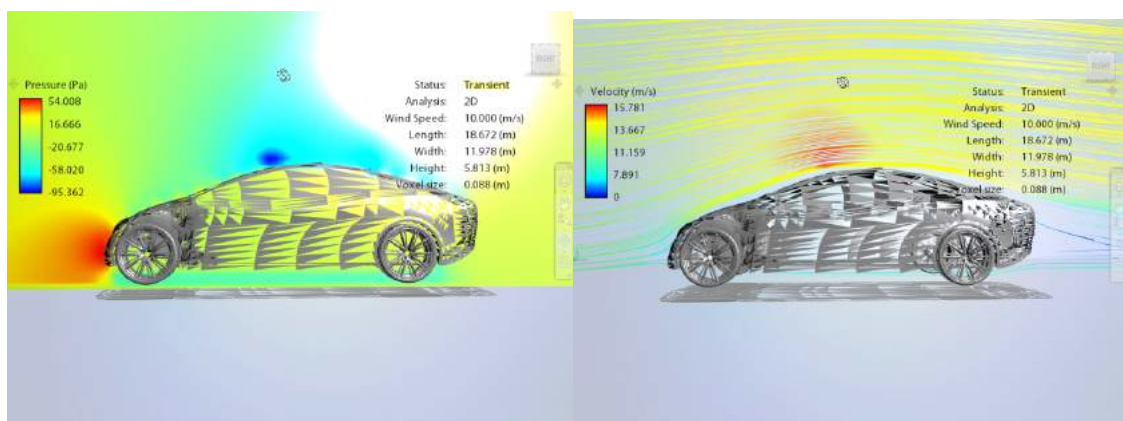

Figure 83. Pressure and velocity plot

## 5. CONCLUSIONS

This chapter includes the conclusions, the recommendations and a number of discussions regarding the project

## 5.1 SUSTAINABILITY

In the upcoming years electric vehicles are going to increase in demand, creating a realistic and sustainable alternative to address CO<sub>2</sub> emissions, and thereby attempting to combat climate change. A debated aspect about sustainability in electric vehicles is the extraction of mineral and metals in an expanding global industry necessary for specific components. This poses a threat to the resource use in the future of the electric car. A suggested alternative is to pass this obstacle by implementing a circular economy in the entire lifecycle of the car, from extraction to reuse.

It has been pointed out that the automobile industry has become one of the major contributors to global air pollution, climate change, smog levels and health issues. The consumption of fossil fuels in this industry is one of the largest in the world and that is why it is essential for manufactures to invest in cleaner technologies. Many have started to shift to more sustainable alternatives, bringing solutions for fuel efficiency and lower emissions. The research on electric vehicles have increased in recent years, achieving vehicles with zero emissions and a sustainable carbon footprint. Overall, the introduction of electric vehicles have set in the public the alternative for a sustainable option. In the future more electric vehicles will be deployed to the market, increasing the impact on the consumer and the driving habits.

The all-electric future is going to redefine the energy grid, changing the how the transportation commute, the lifestyle in urban areas and the understanding of a sustainable driving. To power these new transportation concepts, the energy grid is going to be affected also. Eolic, tidal, solar and nuclear power are CO<sub>2</sub>-free energy sources, and the kind of source the electric vehicles need. Furthermore, the all-electric transportation represents a challenge for current energy sources. In the US, over 68% of the electric energy is produced from fossil fuels, and a large percentage of that comes from burning coal. However, the case in Europe the scenario is different, where many countries are striving for a more sustainable energy generation. Denmark has 90% of the country's grid connected to renewable sources,

specially ocean-wind farms and hydro-electric plants. Hence it is essential to consider the origin of energy for the use in the electric cars, society and governments should strive for renewable sources to power the grid.

One of the biggest threats to sustainability for electric vehicles is the lifecycle emissions, which according to Norwegian University of Science and Technology for the manufacturing of EV the (GWP), Global Warming Potential doubles the production of a traditional IC car. The GWP of EV is around 87-95 grams of CO<sub>2</sub> for equivalent Km driven, when for IC the GWP is 43 grams for CO<sub>2</sub> equivalent Km. The biggest contributor to this difference is the production of the batteries, which is up to 41% of the GWP in the electric vehicles case.

Nevertheless, big advancements have come in the battery and energy technology, mostly making them more efficient and smaller. This will contribute to increase the range of the EV and therefore lower the GWP. Graphene batteries are extremely efficient, being able to charge and discharge up to 33 times faster than current Lithium-compound batteries. This new technology is not just better for charging times, but drives the EV with an extended range, the battery can provide 800 Km of driving in a single charge. This is almost 3 times the range current batteries allow (Graphenano, 2016). Finally, the effective capacity of the battery is 1000Wh/Kg, representing a power – weight ratio of more than 5 times the capacity of Lithium batteries, which is 180Wh/Kg. (Pocket-lint, 2016). Considering the investment in development it is acceptable to assume that the electric vehicles are heading to a sustainable direction, by using more efficient technology, production zero emissions and the use of renewable energy.

The project emphasizes on developing ideas and concepts for the structural architecture of electric vehicles. In this way it is expected to support the evolution of the technology of the electric mobilization, bringing solutions that encompass the specific demands and requirements of EV. The goal is provide answers that improve the architecture, bearing the safety of the passengers as the main priority. Also to contribute in some extent to the devolvement and posterior manufacturing of vehicles

that represents a clean and sustainable alternative. Hence the project supports the global initiative of shifting to a green mobility.

## 5.2 DISCUSSION

Car development is a very large industry and it demands the synergic work of hundreds of engineers, experts on their own areas. It is virtually impossible, without a skilled team, to address a project of these characteristics and develop all the influence points in a very short time. The elements interact with many components and subsystems, each of one is independent and has own demands and characteristics.

The topic started as a wide idea of the BIW structure setting few layouts of the structure. For this project the structural analysis is essential in order to create the features of the design, because it sets the limits for the topology alternatives. In some way this could be contradictory to the established style department, where industrial design is greatly appreciated. However I tried to address the thesis from a project perspective, where the systems are truly interconnected. In this sense every part of the design would affect their peers and have an impact on the final concept.

This method of selecting restrictions is contrary to a completely open-box method, where the free mind can play to create liberal forms. However, I don't find the two methods incompatible, but instead overlapping. As the restrictive design sets the limit points where the geometry can finish, the free thinking will make the most with those boundaries. This perspective is somehow basic for the designer, who can use methods to find boundaries for the design and develop concepts from abstract forms.

Usually in the car industry this process is given the other way around, the stylists create the design of the car and the engineers bear the production methods and the limitations of those. This process results in a slow iterative relation between the style department and the engineering department. Many times creating conflicts on parts or packaging,

because both counterparts have their respective expertise, and both fields give value to the car, of course in different ways. This is the point where the thesis has an essential designer-thinking background to follow limits and set the manufacturing goals, so the process is smoother every time. Leading to a maximised outcome from the designer and fewer impediments from the manufacturing engineers to create those parts. I think that the next step in design is bringing the technology understanding close to the designer, so he is the person who can create and innovate based on proved results that can be applied to the real world.

As this project has been addressed from a holistic perspective, the model had a reduced complexity as many small components were excluded. The simplification of the models was useful for a successful evaluation, but it diverges from more detailed models, and do not reflect in detail the real behaviour of the analyzed components. More accurate models tend to get closer to reality, but it demands large computational power and commonly a team to simulate a completely real scenario with an acceptable error margin.

The body work of the EV has been constrained to the SPA platform, which affects the expression of the vehicle to a restrained framework setting a real platform. Those boundaries are part of the basic approach of the project, however those limitations reduce greatly the freedom on the expression of the product, as some of the defining lines are set and constrained in dimensions.

To sum up, the challenges faced on the project started with the wide perspective of the thesis idea. However, at the end that same wide perspective became its best characteristic, because the thesis was developed as a multi functional product, with many elements interacting and being developed parallel.

## 5.3 CONCLUSION

Electric vehicles are the future of the transportation in many aspects. They are clean, reliable and efficient, giving them outstanding sustainability characteristics. There are many barriers to cope yet to make the EV the primary system of mobilization, especially about the adoption and extension of production vehicles. However, the steps are going in the right direction. Constant development of systems contributes to a rapid evolution of the EV. This is how developments on tractive, energy and structural systems connect the product in a better way and allow the optimization of the parts.

Electric vehicles are meeting a fast adaptation to the market demands as well. They are filling the spaces where the technology provides advantages and creating a much more flexible segment.

As the EV still seems in early steps of adoption many systems have been overlooked or scarcely optimized. This report displays the design thinking process, mapping the requirements and directing on the changes that better fit those demands, focusing on the safety aspects of the structural architecture.

The thesis was developed as a project, with an holistic view of how to design a car. Where a designer has to compromise with different systems and all of them have to work together in synergy.

This is the reason the thesis has many different ways to reach the concept. In the same way the designer has to mind all the elements and subsystems that are directly related to an individual designed part.

On the concrete work of the present project, the developed body in white is a consequence of this particular method of designing. The idea and concept developed developed a suitable proposal that address different problems and filter solutions to obtain a rational final concept, that can be applied to the real world.

## 5.4 RECOMENDATIONS

The concept proposes solutions that can work together in many different systems for an electric vehicle. However, due to the wide area of design addressed, none of the components were fully developed in terms of optimization, interaction and manufacturability. Additionally, for a proper carry over of the work, it would be necessary to take some steps around the proposed concept;

- Run a full-car model simulation in different load cases.
- Design the parts and analyze for stiffness and for collapsing.
- Design and analyze the packaging of the components in the new architecture.
- Design the structure in sheet metal and design the welding joints to shape the edges of the BIW.
- Design for manufacturing using hot stamp.

Many of these steps can be performed individually, but in order to maintain the same thinking of development, they should be investigated in an holistic perspective to created integral solutions.

## REFERENCES

- ANDERSON, C., ANDERSON, J (2010). *Electric and Hybrid cars, A history*. McFarland & Company, Inc. North Carolina
- AZIZAN, Arif. (2014). *Mazda SKYACTIV*. BETA 1, Universiti Kuala Lumpur Malaysian Spanish Institute.
- BAE, H., LIM, J., PARK, K., (2000) *Vehicle Compatibility in Car-to-car Frontal Offset Crash*. Hyundai Motor Company, Korea
- BASTIEN, C., et, al., (2015) Multidisciplinary Design Optimization Strategies for lightweight vehicle Structures. 10th European LS-DYNA Conference 2015, Würzburg, Germany
- BROWN, J., ROBERTSON, J., SERPENTO, S., (2002). *Motor Vehicle Structures: Concepts and fundamentals*. Butterworths-Heinemann, Oxford
- CHRISTIANSEN J., BASTIEN, C., (2015). *Nonlinear Optimization of Vehicle Safety Structures*. Butterworths-Heinemann, Oxford
- EEA European Aluminium Association (2013) *The Aluminium Automotive Manual*. Version 2013, European Aluminum Association
- EuroNCAP New Car Assessment Program (2016). *How To Read The Stars*., Available at: <http://www.euroncap.com/en/about-euro-ncap/how-to-read-the-stars/>. (Accessed: 02-03-2016)
- GRAPHENANO, GRABAT, (2016) *Una empresa española desarrolla una batería con autonomía para 800 kilómetros*. Available at: <http://grabat.es/en/node/35>. (Accessed: 08-05-2016)
- HAPPIAN-SMITH, Julian, (2001)., *An Introduction to Modern Vehicle Design*. Reed Educational and Profesional Publishing, Oxford
- HOBEIKA Teddy, (2016) *Interview at Chalmers Applied mechanics department*, Göteborg, Sweden
- IIHS Insurance Institute for Highway Safety (2016) *About our tests*. Available at: <http://www.iihs.org/iihs/ratings/ratings-info/frontal-crash-tests>, (Accessed: 18-03-2016)
- JOHANNSEN H., et al., (2013) *Parametric modelling of Simplified Car Models for Assessment of Frontal Impact Compatibility FIRM CAR*,. 8th European LS-DYNA Users Conference, Strasbourg, Germany
- LUNDQVIST, Andreas, (2016) *Interview at Volvo Body in White Department*, Göteborg, Sweden
- MACEY, Stuart (2014) *H-Point The fundamentals of car design & Packaging* Design studio press, Art center college of design, Pasadena, CA.
- MISSONI, Maximilian, (2016) *2017 The new Volvo S90 - Official review*. Available at: <https://www.youtube.com/watch?v=wxxLasbLIPg>, (Accessed: 18-03-2016)
- MORGAN, R., (2012) *Front Pole Impacts*, IRCOBI Conference, IRC-12-22
- OHSAKI, Makoto. (2011) *Optimization of finite dimensional structures*. Tyler and Francis group. Florida
- OTT, J. et, al. (2014) *Deliverable 3.1 – Recommendations and Guidelines for Battery Crash Safety and Post-Crash Safe Handling*. EVERSAFE, Everyday Safety for Electric Vehicles. An ERA-Net collaborative project. Work programme: Electromobility

POCKET-LINT, (2016). *Electric car, with light aluminium-air battery, travels 1,100 miles on a single charge, take note Tesla* Available at: <http://www.pocket-lint.com/news/129419-electric-car-with-light-aluminium-air-battery-travels-1-100-miles-on-a-single-charge-take-note-tesla>. (Accessed: 13-05-2016)

REZA, A., SIMSUK, D., (2011) *Influence of the different vehicle subframe configurations in the PDB assessment.*, Department of Applied mechanics, Göteborg, Sweden.

SAE handbook, (1996) *Some considerations in Efficient Design of Light Weight Structures, Technical Papers.*, Fourth International Conference on Vehicle Structural Mechanics, Detroit, Michigan  
ULRICH, Karl, (2003). *KJ Diagrams*. The Warthon school, University of Pennsylvania, Philadelphia

WARREL, A., (2001) *Design syntactics: A functional approach to visual product form*, Chalmers University of Technology, Göteborg, Sweden

WITOWSKI, K., et. al., (2014) *Topology and Topometry Optimization of Crash Applications with the Equivalent Static Load Method*. 13th International LS-DYNA Users Conference. Stuttgart, Germany

WITTERMAN, Willibrordus. (1999). *Improved Vehicle Crashworthiness Design by Control of the Energy Absorption for Different Collision Situations*. Doctoral disertation, Eindhoven Universiteit Eindhoven, Netherlands

# FIGURES REFERENCES

Figure 1. Body-in-white components. Source: Author

Figure 2. The car design process. Source: MACEY, Stuart (2014) H-Point The fundamentals of car design & Packaging Design studio press, Art center college of design, Pasadena, CA.

Figure 3, Horse chariot, Source <http://www.johnnybrunt.com/images/Black%20Brougham%20Carriage.jpg>

Figure 4, 1903 Krieger Brougham hybrid electric vehicle. Front wheel-drive electric motor, 60Km range. Source: [http://www.didik.com/ev\\_hist.htm](http://www.didik.com/ev_hist.htm)

Figure 5. Volvo SPA Plattform. Source: [http://st.automobilemag.com/uploads/sites/11/2015/10/Volvo-CMA-platform-side-view-with-text.jpg?interpolation=lanczos-none&fit=around%7C640%3A400&crop=640%3A400%3B\\*%2C\\*](http://st.automobilemag.com/uploads/sites/11/2015/10/Volvo-CMA-platform-side-view-with-text.jpg?interpolation=lanczos-none&fit=around%7C640%3A400&crop=640%3A400%3B*%2C*)

Figure 6. General dimensions of the car. Source: Author

Figure 7. Roll, pitch and yaw motions. Source: <http://racingcardynamics.com/wp-content/uploads/2015/01/Post1.2Figure2.jpg>

Figure 8. Tesla flat battery positioning below floor. Source: Author

Figure 9. Volvo S90 tractive system positioning. Source: Author

Figure 10. Chevrolet Camaro 2007 BW. Source: <http://i.kinja-img.com/gawker-media/image/upload/s--VXtfDAHY--/1290943402160668451.jpg>

Figure 11. Load path along the BMW. Source: [http://www.mazda.com/content/assets/9e1112833097497a988c5a54525e25da/skyactiv-body\\_05.jpg](http://www.mazda.com/content/assets/9e1112833097497a988c5a54525e25da/skyactiv-body_05.jpg)

Figure 12. Moderate overlap test. Source: Author

Figure 13. Example of a vehicle impacted on a moderate overlap real situation. Source: <http://s172.photobucket.com/user/wmdavis007/media/DSC014081.jpg.html>

Figure 14. Full rigid barrier test. Source: Author

Figure 15. Small overlap test. 25% offset. Source: Author

Figure 16. Example of a vehicle impacted by a small overlap real situation. Source: <http://www.wvgazette.com/apps/pbcsi.dll/storyimage/>

CH/20150402/DM01/150409865/AR/0/AR-150409865.jpg

Figure 17. Horizontal vehicle misalignment. Source: Author

Figure 18. Fork effect on two collapsing vehicles car-to-car misalignment. Source: REZA, A., SIMSUK, D., (2011) Influence of the different vehicle subframe configurations in the PDB assessment., Department of Applied mechanics, Göteborg, Sweden.

Figure 19. Front pole in the middle of the car width. Source: Author

Figure 20. Real examples of a front pole impact. Source: <http://www.glitters20.com/wp-content/uploads/2012/11/Funny-Cars-54.jpg>

Figure 21. Front to end vehicle incompatibility. Source: <http://www.chaniapost.eu/wp-content/uploads/2014/08/car-accident.jpg>

Figure 22. Volvo XC90 2016 small overlap test. Source: [https://www.youtube.com/watch?v=Rf7t\\_DOCSgg](https://www.youtube.com/watch?v=Rf7t_DOCSgg)

Figure 23. Audi Q7 2017 small overlap test. Source: <https://www.youtube.com/watch?v=dfG4SqPYcSA>

Figure 24. 2017 Audi Q7 small overlap test load path. Source: Author

Figure 25. 2016 Volvo XC90 small overlap test load path. Source: Author

Figure 26. Frontal structure of EV. (a) 2014 BMW i3. (b) 2013 Tesla model S. Source: <http://media.caranddriver.com/images/media/51/2014-bmw-i3-inline-1-photo-526624-s-original.jpg>

Figure 27. 2016 Volvo XC90 moderate overlap. Source: <https://www.youtube.com/watch?v=TEyL3N0aldk>

Figure 28. CAD model context of the frontal structure of a XC90. Source: Author

Figure 29. Finite element mesh. Source: Author

Figure 30. Total deformation of the sidemembers, plate elements model. Source: Author

Figure 31. Bending points along the sidemember. Source: Author

Figure 32. 'Z' shape failure design. Source: Author

Figure 33. XC90, 2007 Engine Bay and components. Source: <http://www.roadfly.com/volvo-xc90-car-review-and-video-2007.html>

Figure 34. XC90, 2015 Engine bay and components. Source: <http://www.digitaltrends.com/cars/2015-volvo-xc90/>



Figure 35. BMW i3 front storage. Source: <http://www.thetruthaboutcars.com/wp-content/uploads/2015/03/2015-BMW-i3-Range-Extender-Front-Trunk-Frunk.jpg>

Figure 36. Frontal storage use of the Tesla Model S. Source: Author

Figure 37. Recurrence of use. Source: Author

Figure 38. Funcional model. Source: Author

Figure 39. Solution mode. Source: Author

Figure 40. KJ method for interview. Source: Author

Figure 41. Concept design spheres. Source: Author

Figure 42. Inclined side members. (a) divergent, (b) convergent. Relative to origin point. Source: Author

Figure 43. Current EV structure. Source: Author

Figure 44. Representation of sidemembers as cantilever beam. Source: Author

Figure 45. Representation of sidemembers as an open frame structure (a) stress (b) displacement. Source: Author

Figure 46. Ring frame and diagonal braced frame (source: Happian-Smith, 2001). Source: HAPPIAN-SMITH, Julian, (2001)., An Introduction to Modern Vehicle Design. Reed Educational and Profesional Publishing, Oxford

Figure 47. Representation of sidemembers as truss structure. Source: Author

Figure 48. Height difference between the battery pack and the bumper. Source: Author

Figure 49. Impact vector and resultants. Source: Author

Figure 50. Datum on connecting side members. Source: Author

Figure 51. Batteries and firewall. Source: <http://s1.paultan.org/image/2013/07/bmw-i3-113-108x108.jpg>

Figure 52. Tunnel in the floor structure and firewall. Source: <https://racingnews-walterswebdesign.netdna-ssl.com/files/2015/05/Lamborghini-SUV-Coming-2018-Lamborghini-Urus-Technology.jpg>

Figure 53. Car energy diagram. Source: Author

Figure 54. Car energy diagram with battery release. Source: Author

Figure 55. Aluminum honeycomb impact absorber. Source: Author

Figure 56. Deformable brackets. Source: Author

Figure 57. Pyro nuts battery release. Source: Author

Figure 58. Frontal architecture working as an integral structure. Source: Author

Figure 59. Frontal volume comparison. Source: Author

Figure 60. Tire envelope and horizontal suspension. Source: Author

Figure 61. Cooling pack positioning on the Tesla model S. Source: Author

Figure 62. Cooling pack between the sidemembers. Source: Author

Figure 63. Rear cooling pack. Source: Author

Figure 64. 95th percentile male to 5th percentile female. Source: Author

Figure 65. Ergonomic points in the Volvo S90. Source: Author

Figure 66. Ergonomic dimensions for the concept. Source: Author

Figure 67. EV Concept in the Volvo segment context. Source: Author

Figure 68. EV Concept in the competitor segment context. Source: Author

Figure 69. Design form analysis of Volvo brand. Source: Author

Figure 70. Explicit Volvo design cues. Source: Author

Figure 71. Expression board for EV. Source: Author

Figure 72. The not desired board. Source: Author

Figure 73. Solution filtering, gates method and process. Source: Author

Figure 76. Connecting sidemembers. Source: Author

Figure 77. Deformation and load paths on the connecting members. Source: Author

Figure 78. Angled crossmember. Source: Author

Figure 79. Air cooling for the battery. Source: Author

Figure 80. Battery as a free weight . Source: Author

Figure 81. Ergonomics and accessibility. Source: Author

Figure 82. EV Concept, the Volvo feeling. Source: Author

Figure 83. Pressure and velocity plot. Source: Author

## APPENDIX

User study survey, results from 22, April, 2016 to 05, may, 2016

Gender (54 responses)

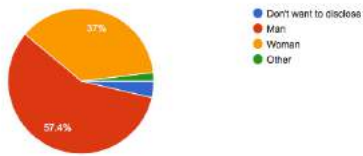

Age (54 responses)

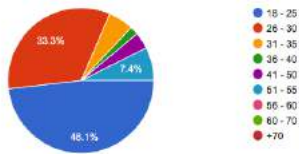

Household composition (54 responses)

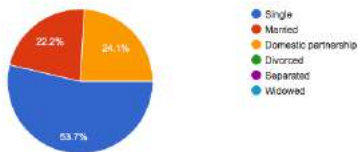

Professional or Employment status (54 responses)

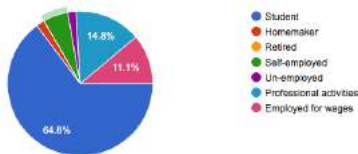

Do you have a driver license? (54 responses)

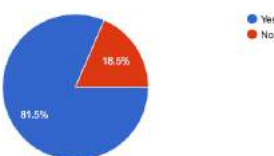

Electric vehicle attributes

Cost (52 responses)

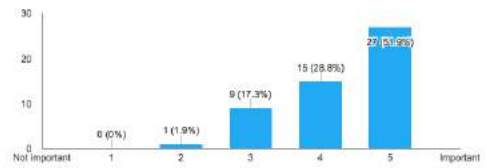

Number of passengers (51 responses)

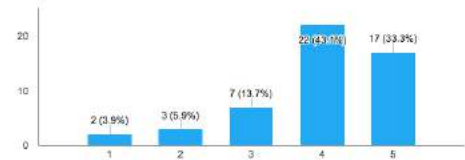

Economy (51 responses)

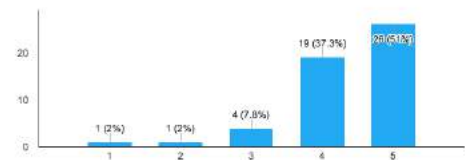

Interior space (52 responses)

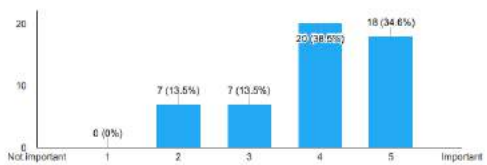

Cargo volume (52 responses)

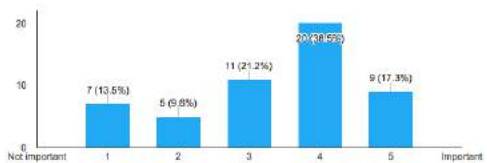
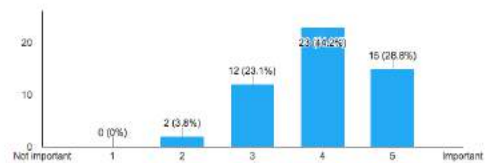
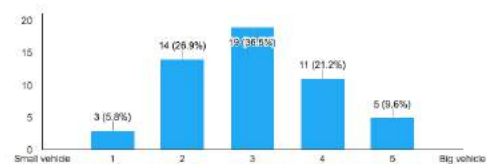

Image (52 responses)



Size (52 responses)



Trim level (52 responses)

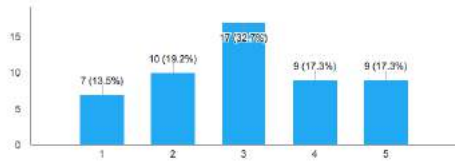

Range sound (52 responses)

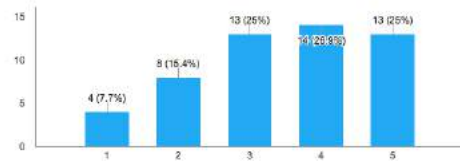

Security (52 responses)

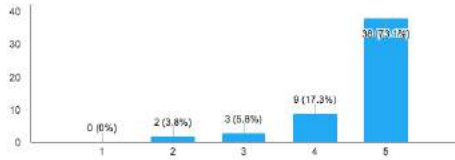

Safety/crashworthiness (52 responses)

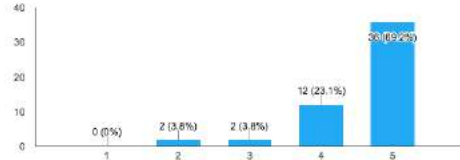

Weight (51 responses)

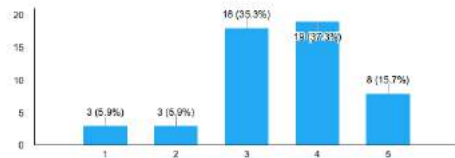

Environment concern (36 responses)

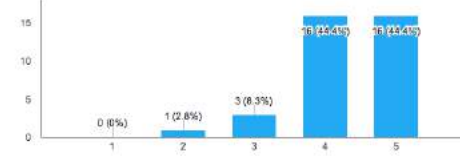

Handling (52 responses)

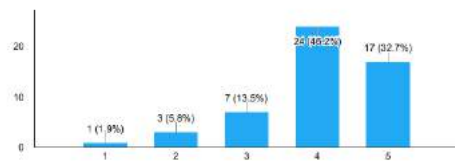

Sustainability (36 responses)

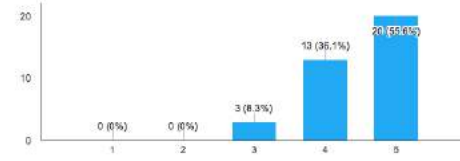

Colors (52 responses)

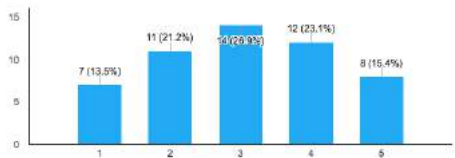

Compact economy segment (46 responses)

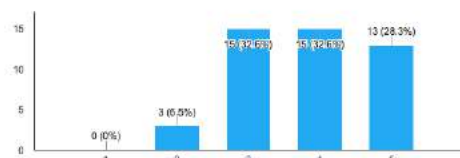

Noise/vibration/harshness (NVH) (52 responses)

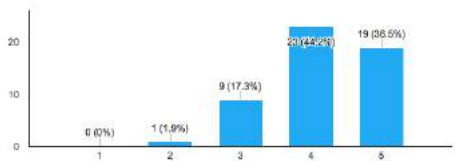

Innovative technology (35 responses)

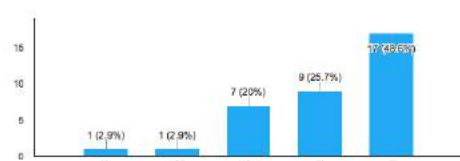

Luxury segment (45 responses)

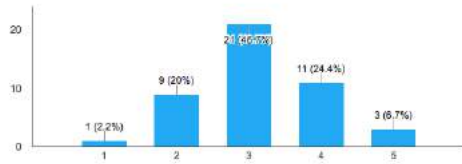

Brand identity (52 responses)

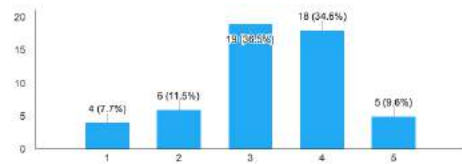

Sport segment (45 responses)

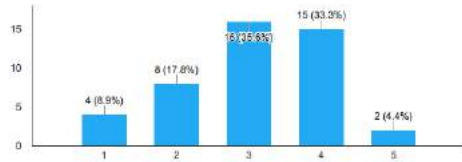

Power (51 responses)

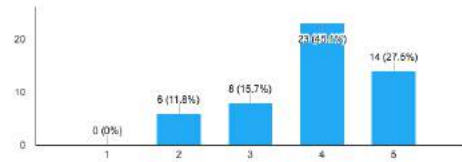

Aftermarket component availability (52 responses)

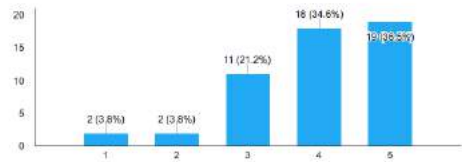

Off-road capability (52 responses)

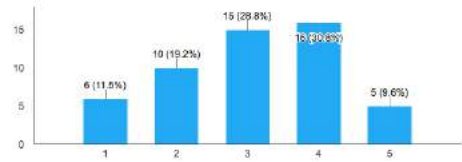

Easy Ingress/egress maneuverability (52 responses)

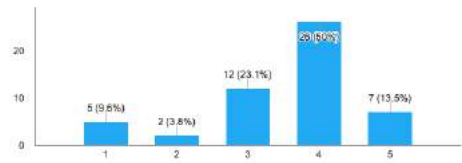

Comfort (51 responses)

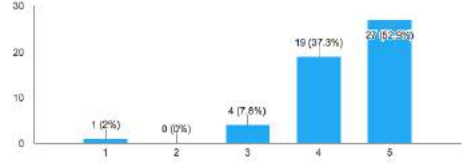

Flexibility (52 responses)

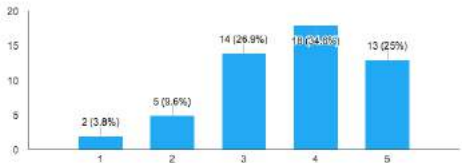

Range (miles to run on single charge) (52 responses)

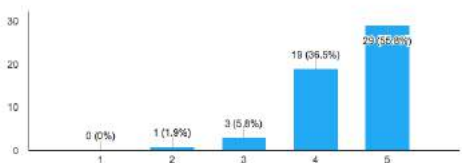

**Durability** (51 responses)

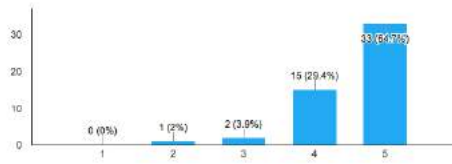

**Speed** (51 responses)

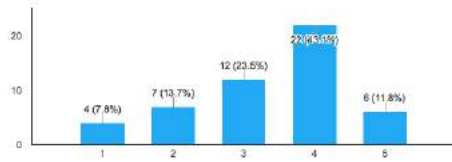

**Low emissions** (52 responses)

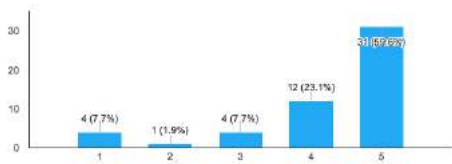

**Towing capacity** (51 responses)

