



CHALMERS



A collapsible chair for Blå Station

Master thesis within the Industrial Design Engineering programme

Marc Hoogendijk & David Lamm

A collapsible chair for Blå Station

© Marc Hoogendijk & David Lamm 2015

marc.hoogendijk@gmail.com
deju.lamm@gmail.com

Printed by reproservice at Chalmers

Gothenburg, 2015

Abstract

Blå Station is a premium furniture producer targeting offices and public spaces. Their philosophy “design from an innovative perspective” is something that can be seen throughout their products, which often feature a novel manufacturing method or innovative use of materials.

The aim of this master thesis project is to develop a production ready, collapsible chair. The chair is to fit Blå Stations brand essence and the market’s perceived image of the company. The chair should fulfill all the found demands and requirements regarding ergonomics, branding, mechanical durability, safety, sustainability and economy.

A thorough research of collapsibility principles, manufacturing techniques, Blå Station as a brand and the market has been performed to gain a good understanding of the preconditions that the chair is to face. This was followed by an extensive ideation phase where numerous possible solutions and concepts were generated which resulted in a final concept called Applåd.

Applåd is a reinterpretation of the classic beach chair, in Sweden referred to as the ”Brasse” chair. A chair with maybe the worst reputation of quality and a big stamp of temporarity in its forehead. By adding innovative materials and design the Applåd chair have transformed it into a premium chair expressing quality and non-temporarity.

The result is a chair which aims to be perceived not as a fragile collapsible chair but a steady and trustworthy chair which has the collapsibility added to it as a bonus function.

Keywords: Industrial Design, collapsibility, folding, chair, innovation, novel design, Blå Station.

Sammanfattning

Blå Station är en svensk möbelproducent som med kvalitativa produkter för offentliga miljöer riktar sig mot den professionella sektorn. Deras filosofi "design från ett innovativt perspektiv" är något som genomsyrar hela deras produktsortiment. Deras möbler använder sig ofta av en nyskapande tillverkningsmetod eller en innovativ materialapplikation.

Målet med detta examensarbete är att utveckla en produktionsfärdig fällbar stol. Stolen skall passa Blå Stations varumärkesessens samt marknadens upplevda bild av företaget. Stolen skall uppfylla alla funna krav och behov gällande ergonomi, varumärke, mekanisk hållbarhet, säkerhet, miljö och ekonomi.

En djupgående analys av hållbarhetsprinciper, tillverkningsmetoder och Blå Stations varumärke genomfördes för att skapa en djup förståelse för de krav som ställs på stolen. Denna följdes av en omfattande idégenereringsfas där en stor mängd möjliga lösningar och koncept genererades. Denna process resulterade i ett slutgiltigt koncept kallat Applåd.

Applåd är en modern tolkning av den klassiska strandstolen "Brasse". En stol med mycket dåligt rykte gällande kvalitet och som uppfattas som extremt temporär. Genom att addera innovativa material och ett gediget formspråk förvandlar Applåd brassestolen till en högkvalitativ stol som uttrycker stabilitet och icke-temporaritet.

Resultatet är en stol som inte uppfattas som en vek fällbar stol utan istället som en stadig och pålitlig stol som har hållbarheten som en bonusfunktion.

Nyckelord: Industridesign, hållbarhet, stol, innovation, nyskapande, Blå Station.

Acknowledgements

This project has been realised with the help of a number of persons outside of the project group.

We would like to thank Blå Station's CEO Johan Lindau for being our company tutor in this project. His input and drive to share his deep knowledge about the furniture industry has been invaluable.

We would like to thank our project examiner and supervisor at Chalmers, Professor in Industrial Design - Ulrike Rahe for guiding us through hard decisions and leading us through a structured design process.

Thank you Kjell & Torleif at SSPA for helping us to mill the tool for the seat, backrest and armrest.

Jan, Nisse and Reine at Chalmers prototype laboratory for helping us develop and construct the prototype.

Niklas Åberg at NÅ Formtextil in Halmstad for helping us manufacture and design the felt components.

Magnus Weinbach & Johan Nicklasson at Bending group for helping us manufacture and design the steel tubing components.

Taina Flink at Stena Metall for giving us a better understanding of the sustainability aspects.

All the people who took part in our ideation and evaluation processes.

Our thesis opponents, Oskar Karlsson and Petter Polson for sharing their valued opinions about our report and presentation.

Sara Ricciardi, Milan for housing and feeding us when we were stranded on the streets of Milan.

Our families who have supported us and lent us cars.

Viktoria & Ulrika.



David Lamm



Marc Hoogendijk

Contents

1.	Introduction	10		
1.1.	Project Background	10		
1.2.	Purpose	10		
1.3.	Aim	11		
1.4.	Delimitations	11		
1.5.	To note	11		
2.	Blå Station	12		
2.1.	Brand specifics	12		
2.2.	Blå Station's History	13		
2.3.	Environment	13		
2.4.	Blå Station's core values	13		
2.5.	Blå Station's customer & user	14		
2.6.	The bad reputation of the collapsible chair	15		
2.7.	Smart and simple construction	15		
2.8.	The ultimate collapsible chair	16		
3.	Knowledge Base	18		
3.1.	History of collapsible chairs	18		
3.2.	Areas of use	20		
3.3.	Collapsibility as a phenomenon	20		
3.3.1.	The twelve principles for collapsibility	20		
3.4.	Novelty in the furniture field	22		
3.4.1.	Most advanced, yet acceptable	22		
3.4.2.	Maximum effect for minimum means	23		
3.4.3.	Unity in variety	23		
3.5.	Semantic aspects	23		
3.5.1.	Gestalt	23		
3.5.2.	Semantic principles	25		
3.6.	Visual brand identity	26		
3.6.1.	Core Values	26		
3.6.2.	Brand Essence	26		
3.6.3.	Visual Brand Recognition	26		
3.6.4.	Visual Design Cues	27		
3.7.	Ergonomics	29		
3.7.1.	Physical ergonomics	29		
3.7.2.	Cognitive Ergonomics	29		
3.8.	Fields of interest	30		
3.8.1.	Mass Customization	30		
3.8.2.	Biomimicry	30		
3.8.3.	Integrated materials	30		
3.8.4.	Origami	30		
4.	Methods	32		
4.1.	Information gathering methods	32		
4.1.1.	Interviews & Consultations	32		
4.1.2.	Literature review	32		
4.1.3.	Study visits	32		
4.1.4.	Fairs	33		
4.1.5.	Design format analysis (DFA)	33		
4.1.6.	List of functions	33		
4.1.7.	Specification of requirements	33		
4.2.	Ideation & Evaluation methods	34		
4.2.1.	Mood Boards	34		
4.2.2.	Brainstorming	34		
4.2.3.	Morphological matrix	34		
4.2.4.	Focus Group	34		
4.2.5.	Sketching and visualizations	34		
4.2.6.	Computer Aided Design	35		
4.2.7.	Physical models	35		
4.2.8.	Pugh matrix	35		
4.2.9.	Design for assembly (DFA)	35		
5.	Results	36		
5.1.	Literature	36		
5.2.	Interviews	36		
5.3.	Visits to furniture fairs	37		
5.4.	Condensing inspirational data into Morphological Innovative Spurs			
	Sentences	37		
5.4.1.	Application of the method	39		
5.5.	Study visits	40		

5.5.1.	Elmo Leather, Svenljunga.	40	8.	Refinement & Prototyping	70
5.5.2.	Stena Metall, Göteborg & Borås.	41	8.1.	Manufacturing of Applåds frame	72
5.5.3.	SAPA group, Vetlanda.	42	8.2.	The joints	74
5.5.4.	Porstlinsfabriken Lidköping	42	8.3.	The locking detail	75
5.5.5.	Swedese	42	8.4.	Developing the seat and armrest	76
5.5.6.	Andrénplast, Göteborg	43	8.5.	Manufacturing seat and armrest	78
5.5.7.	Bending Group	43	9.	The final design	80
5.5.8.	NÅ Formtextil	44	9.1.	The Applåd Collapsible Chair	80
5.6.	Defining the user and context	45	9.1.1.	The frame and visual expression	80
5.7.	Functional guides	45	9.1.2.	The seat and backrest	82
5.8.	Anthropometric properties	46	9.1.3.	The armrest	83
5.9.	Mental models of collapsible chairs	47	9.1.4.	The adjustment of the backrest angle	84
5.10.	Market positioning	47	9.1.5.	The collapsing procedure.	84
5.11.	Visual brand identity of Blå Station	48	9.2.	Cognitive and physical ergonomics	84
5.12.	Core values of the Applåd chair	50	9.2.1.	The manufacturing procedure	85
5.13.	Core value Mood board.	50	9.2.2.	Sustainability aspects	86
5.14.	Inspirational board.	51	10.	Discussion	88
6.	Creative Ideation	52	10.1.	Reaching our goals	88
6.1.	Ideation process	52	10.2.	Methodology	89
6.2.	Material Process / Form possibility based ideation	53	10.3.	Amount and level of completion of concepts to present	89
6.3.	Group ideation	53	10.4.	When to let go - Kill your darlings	90
6.4.	Sketch'a'day	54	10.5.	Collapsibility principles	90
6.5.	Tramstorming	54	10.6.	Designing for production	90
6.6.	Modeling ideation	54	10.7.	The key factors for a successful collapsible chair	91
6.7.	Idea evaluation	55	11.	Conclusion & Recommendations	92
6.7.1.	The eleven functional concepts	56	11.1.	Summing things up	92
6.8.	Evaluation outcome	62	11.2.	Recommendations	93
7.	Concept Development	64	12.	References	94
7.1.	Developing the frame structure	64	13.	Appendices	96
7.1.1.	The Unileg	65			
7.1.2.	The Split	66			
7.1.3.	The Simplex	67			
7.2.	Concept Evaluation	68			

1. Introduction

This section covers the background of the project, why it has been carried out and what the aim and goal is.

1.1. Project Background

Founded by Börge Lindau in 1986, Blå Station is still as restless as always, constantly searching for new ways to push the development forward and surprising their spectators. Their philosophy “design from an innovative perspective”, is something that can be seen throughout their products which often feature a novel manufacturing method or innovative use of materials.

The company is renowned for being a premium furniture producer targeting offices and public spaces as well as for its focus on sustainability, a focus which is reflected through several certifications such as Svanen.

When it comes to collapsible furniture, Blå Station’s portfolio features the simplistic folding chairs Beplus and Sparta. Both designed by Börge Lindau in 1987 & 1993.

Blå Station’s CEO Johan Lindau has been looking to saturate the portfolio with a new folding chair for quite some time.

1.2. Purpose

Blå Station’s portfolio mainly consists of chairs, stools, armchairs and tables. They currently have two models of collapsible chairs which are simplistic, functional and expresses temporarity. What the product portfolio lacks is a collapsible chair that has an expression which is not as temporary. The user should not feel the need to collapse and store the chair in between uses. The chair should be perceived more like an ordinary chair than a folding one but still communicate its collapsibility.

The purpose of this Masters thesis is to design this collapsible chair. The design is to fulfill the listed requirements, it should fit Blå Station’s brand and be well adapted to the context in which it is to be used

A chair with focus on innovation, yet well adapted to affordable production is to be designed. It is to express non-temporarity, meaning that the user should not feel a need to collapse and put the chair away when not using it. In a larger context the chair is to stand up against the preconception of a collapsible chair being of low quality, uncomfortable and cheap.

1.3. Aim

The project aims to explore collapsibility as a phenomenon, starting with the most elementary collapsibility principles, developing, evaluating and refining the findings into a functional chair prototype well adapted to reality and its production techniques. The project aims to result in a collapsible chair but the specific functionality will not be set from the start. Instead a broad spectra of chairs will gradually narrow down until a specific functionality is settled.

Another aim is to gain a deep understanding of the manufacturing industry in order to develop a product well adapted to existing manufacturing techniques, as well as trying to find novel materials and new ways of using existing techniques.

The project is to result in a production ready, collapsible chair. The chair is to fit Blå Station's brand essence and the markets perceived image of the company. The chair should fulfill all the found demands and requirements regarding ergonomics, branding, mechanical durability, safety, sustainability and economy.

The project also aims to find answers to the following questions:

- What are the key factors to designing a successful piece of (collapsible) furniture?

- What constitutes a novel / innovative piece of (collapsible) furniture?

- What types of collapsibility exists and which ones are more suitable for chairs?

- What make a product's expression temporary / permanent? - Is the collapsibility part of this expression?

- What knowledge of manufacturing processes is required to design a piece of furniture well prepared for production?

1.4. Delimitations

A part of Blå Station's business strategy is that all their products are manufactured in Sweden or its closest Scandinavian neighbours. This means that production alternatives outside of Sweden will not be looked at in this report.

As a result of this, a high level of effort must be put into developing a cost efficient production process. The cost of the production is a delimitation of this project but varies depending on the type of chair finally designed. As an example an ordinary collapsible chair can be allowed to cost between 400 and 600 SEK to produce while a collapsible armchair can cost up to 2000 SEK.¹ Blå Station has also put up environmental demands which the chair is to fulfil.

1.5. To note

The chair designed in this project will for the sake of convenience be referred to as the 'Applåd' chair. 'Applåd' being a play on the Swedish word 'klappstol'.

¹ Johan Lindau (CEO Blå Station) Interview on the 12th of February 2011 at Stockholm Furniture Fair

2. Blå Station

This chapter analyses Blå Station and their product portfolio to gain a good understanding about the company background and brand.

2.1. Brand specifics

Blå Station is a premium furniture producer targeting offices and public spaces. Their philosophy is “design from an innovative perspective”, something that can be seen throughout their products which often feature a novel manufacturing method or innovative use of materials. The company is also renowned for its focus on sustainability, a focus which is reflected through several certifications, Svanen being one of them. (Blå Station’s website 2011)

Blå Station’s portfolio mainly consists of chairs, stools, armchairs and tables. They currently have two models of folding chairs which are very simplistic, functional and expresses temporariness. See Figure 1. One of them, Beplus, has been active in Blå’s portfolios since 1987 and is still going strong.

An important part of Blå Station’s business strategy is that all their products are manufactured in Sweden. As a result of this, a high level of effort must be put into developing a cost efficient production process. Placing all manufacturing in Sweden gives Blå Station control of the production process and assures high quality and fair working conditions.



Figure 1. Börge Lindaus Beplus (1987) and Sparta (1993)



2.2. Blå Station's History

Blå Station was founded in 1986 by Börge Lindau who after many years of partnership with Bo Lindekrantz decided to return to his origins in Åhus. His original concept was to develop a collection of stools, chairs and tables from the idea of a simple compression moulded birch ring. For many years to come Blå Station's form language was strongly associated with this round shape, birch and stainless steel.

As Börge started his own business he suddenly could do things the way he wanted, he used this freedom to create a strict set of rules where he stated that the furniture produced must consist of environmentally friendly materials that as far as possible should be harmless to manufacture, use and recycle. This set of rules is the foundation of Blå Station's environmental policy of today.

Since then Blå Station has developed the expressions, materials and shapes in close collaboration with new designers and industries.

2.3. Environment

Care of the environment has since the start been close to the heart of Blå Station. Their work has a foundation of seven plus one criteria for sustainable development. The list below is quoted from Blå Station environmental policy. (Blastation.se, Miljö, 2011)

- Higher material quality for better furniture with longer durability.
- Higher design quality to ensure that the furniture is modern and can remain in the market for a longer time.
- Higher environmental awareness so that production and processes become environmentally efficient and

energy consumption decreases.

- Higher logistic environmental awareness to reduce transports.
- Recyclable materials to reduce raw-material consumption.
- Renewable materials to conserve the Earth's resources
- Ethics & Morality to make sure the furniture is made according to the best and most honest human values.

The plus one criteria is to produce all components locally in Sweden.

"Blå Station supports freedom of association and recognises the right to collective bargaining. We oppose all forms of forced labour, child labour and discrimination concerning employment and performance of work tasks." (Blastation.se, Miljö, 2011)

Placing all their manufacturing in Sweden gives Blå Station control of the whole process and assurance that the labour work under fair conditions.

Their environmental care is extensive but rarely communicated to the end user through the furniture itself. Instead it is communicated through product certifications, brochures, the web and word of mouth.

2.4. Blå Station's core values

Every product produced by Blå Station should deserve a place in the market. By always being *curious* they look for the new and unexpected.

For Blå Station to consider a piece of furniture as new, this must show a new attitude towards shape, function, material or the manufacturing process. *Innovation* is the keyword.

The ever changing society and social life of people is something that is given much attention by the people at Blå Station; "Our thoughts are focused on the interiors that surround us – how they are built and how they work. How do we interact in the public space?"



Has today's society added new demands? Has our way of socializing changed? There are many questions that inspire us to think differently." (Blå Station's homepage, About us. 2011)

As mentioned earlier the environmental focus of Blå station is comprehensive. They work with their seven plus one criteria and strive to be on the environmental frontier of the furniture industry.

Blå Station wants to be perceived as *innovative, curious* and *environmentally friendly*. One can say that these are the core values of the company, the foundation upon which the brand spirit is built.

Blå Station's Brand essence is "Design from an innovative perspective.". On their homepage Blå station develops further; "To meet the demands and desires of today we believe it is necessary to have an open and innovative mind, a child's curiosity - and a heart that refuses to take the easy way out." (Blå Station's homepage, About Bla, 2011).

Blå Station's Focus

Two of Blå Station's core values are innovation and curiosity. By always asking questions and challenging the norm they drive the development forward. The innovation takes many forms; new ways of using industrial processes, new shapes and new ways of designing their furniture for our social life. As examples of these we have:

Sting – Sting challenged the aluminium extrusion industry by pushing the limits of how big and thin an extruded piece could be. See Figure 2.

Innovation C - This swivel seat encourages the user to vary his/hers seating position and sit as she likes, simple shape combined with a multitude of functions. See Figure 3.

Peekaboo - Made from laminated formfelt Peekaboo challenged not only the industry but also explored the personal integrity and space of the user. See Figure 4.

2.5. Blå Station's customer & user

Blå Station produces furniture for the professional sector, therefore the customer and the user of the chair are seldom the same person.

The customer

New products reach Blå Station's customers mainly through fairs and reseller events, but also through media channel such as magazines and design blogs.

Blå Station also works strategically to market themselves to selected customers;

"We market ourselves through visits to architects and other clients. As the architect has made up his mind in regard to which furniture that suit the locale, a specification is written of which furniture is *recommended*. However there is a paragraph often used which claims that the chosen furniture can be *replaced with equivalent furniture*. This is a problem since equivalent can mean so many things, the furniture in the specification can be replaced by other furniture with equivalent cost, colour, looks etc." ²



Figure 2. Sting - by Fredrik Mattson and Stefan Borselius 2003



Figure 3. Innovation C by Fredrik Mattson 2001

This leads to a lot of extra work for Blå Station in order to protect their order.

The main customer group for Blå Station is architects and secondly interior design companies, such as European Furniture Group and Kinnarps. The end user has little to say when it comes to which furniture that is to be bought. "With all right" says Johan, "they don't know what they want! We've tried to market us to the home environments but with little success."²

The user

In many cases the user is not the one who unfolds the chair. Imagine a museum that is to have a lecture in one of their exhibition halls. It is then the janitors' task to unfold and place the 100 chairs needed for the guests. This puts high demands on simple collapsibility and stacking of the chairs as the maneuver is to be repeated over and over again. The collapsing procedure does not necessarily have to be intuitive but can be learnt.

² Johan Lindau (CEO Blå Station) Interviewed on the 12th of february 2011 at Stockholm Furniture Fare

On the other hand, in the case that a first time user herself is to handle the collapsing of the chair the handling needs to be intuitive. Therefore this novel user is the limiting factor that the chair needs to be designed for.

2.6. The bad reputation of the collapsible chair

According to Blå Station² and the impression the project group has obtained during the research for this project, the common view on collapsible chairs is that of a chair which is cheap, has low quality and is uncomfortable/unergonomic. The requirement of a flat collapsed state is often hard to combine with comfort and as the price needs to be low, despite the relatively advanced construction, the quality often suffers.

2.7. Smart and simple construction

All of Blå Station's furniture is produced in Scandinavia, mainly in Sweden. Therefore the demand on cost efficient production is high. Cheap and simple construction solutions that can be produced on a small scale are necessary to keep the price as low as possible. As Johan Lindau says "Reduce, reduce, reduce" meaning cut out all unnecessities to create an as efficient but yet attractive design as possible.

According to Blå Station² the customer is unwilling to pay more for a collapsible chair than for a stackable, despite the fact that a collapsible chair often is more expensive to manufacture than the other. This unwillingness is hard to affect but since Blå Station produces high end furniture there is room to produce a collapsible chair that meets the demands on high quality without exceeding the cost of an average stackable chair in the sector.



Figure 4. Peekaboo by Stefan Borselius 2005

2.8. The ultimate collapsible chair

To better understand Blå Station's vision of the collapsible chair, Johan Lindau was asked to describe what the ultimate collapsible chair looks like in its passive and active state. His answer was short and concise; "Good looking and good looking".

He developed further by saying; "collapsible chairs should be comfortable but doesn't have to be super ergonomic, they are made for shorter periods of seating. They should take up as little space as possible but the thicker they are, the higher are also the demands on comfort. There can be no risk of trapping one's fingers. It should be intuitive to collapse and have a stable expression. Big folding movements are often better than small. Integrate as much of the functionality into every piece of the chair. Use as few components as possible."³

Johan was also asked if he thought that an impressive collapsing functionality, with a so called wow-effect, would help to sell the product. Johan was of the opinion that the wow-effect can be relevant as long as it doesn't conflict with the purpose and clarity of the function of the product.

Johan summarised his view of the furniture field by the following statement:

"I see furniture as tools. It is the purpose of the furniture that needs to be the focus of the functional development. The essence of design is to communicate a clear message!"

"I see furniture as tools. It is the purpose of the furniture that needs to be the focus of the functional development. The essence of design is to communicate a clear message!"

- Johan Lindau, CEO of Blå Station

When asked if he had any suggestions of collapsibility techniques that should be investigated, Johan answered that the side-to-side folding, as in a classic director's chair, is a form of collapsibility rarely used nowadays. Most collapsible chairs uses the front-to-back collapsing procedure and by using side-to-side collapsing a blank space on the market can be filled. He also noted that one should not be afraid to look for inspiration and solutions in classic products.

³ Johan Lindau (CEO Blå Station) Interviewed on the 12th of february 2011 at Stockholm Furniture Fare



Figure 5. Johan and Mimmi Lindau in the early days of Blå Station

3. Knowledge Base

This chapter describes theories and facts that was used as foundation for the design process. The areas covered are: history, collapsibility principles, novel design, semantics, visual brand identity, ergonomics and fields of interest.

3.1. History of collapsible chairs

Like many products of today, the collapsible chair was originally developed for military use. The history of the chair dates back as far as 2000 – 1500 b.c when the Egyptians developed the collapsible stool as portable seating furniture for the commanding officers in the army. (See Figure 6.)

It was for a long time considered to be one of the most important pieces of furniture and a prized status symbol. It was a symbol of authority and its development can be traced through numerous cultures up until today.

The early collapsible stool consisted of two four-sided interlocking frames made of wood and a seat of leather. It was later developed into a chair with a backrest as can be seen on for example Tutankhamun's throne. (See Figure 7). It is not known if the Egyptians used the stool with the crossed legs facing forward or to the side. However during the Greek era the stool is depicted with the X placed laterally. The stool was no longer a stool only for commanders and emperors but was also used as a part of the everyday life, especially in the homes of families of high social status.



Figure 6. Collapsible stool from Thebes, 1450-1400 BC

The Egyptian folding stool (via the Greek and Etruscan) became the inspiration for “sella curulis”, the roman collapsible stool. (See Figure 8). The stool was now often placed on a podium, a carriage or given high legs and a footrest in order to give the chair a more distinguished appearance. A cushion was often used for increased comfort.



Figure 7. Tutankhamun's throne

During the medieval age the collapsible stools was developed by multiplying the X shape in the z-direction. See Figure 9. This gave a light and rigid stool and at the same time armrests.

Just before the renaissance (16th century) the folding chair grew more common. The collapsible chairs of the renaissance typically had curved legs inspired by the roman "sella curulis". These were double curved, giving the impression that the front X-shape was made out of one solid piece.



Figure 9. Collapsible 'scissors' armchair

During the 17th and 18th century the collapsible chair became part of the domestic furnishing. Due to the return of the baroque period's rich ornamentation, the chairs with crossed legs were not always collapsible. During this period the X-structure had often exclusively symbolic value.

The collapsing chair became increasingly popular, and so did the collapsing variety and technical solutions. This led to a reduced status value of the chair, but also a wider span of uses and design solutions. By the 19th century the collapsible chairs were widely spread as flexible seating furniture for public spaces that had a need for chairs that could be frequently rearranged. (Lohmann 2003)



Figure 8. Roman collapsible stool 'Sella Curulis'

3.2. Areas of use

The main goal of a collapsible chair is to create a basic seating surface that is comfortable for a shorter time of use and which after use can be collapsed and stored with ease.

In today's society there is a chair for every need and necessity. Collapsible chairs can be found in almost every home, as extra chairs, bar stools or even lounge chairs. As people go camping, hiking or to the beach they bring compact and light collapsible chairs. In public spaces such as lecture halls, museums, exhibitions, schools, cinemas and restaurants collapsible chairs are present and function as flexible seating.

3.3. Collapsibility as a phenomenon

The concept of collapsibility can, according to Mollerup (2001), be said to have two states; One passive and one active state. The passive being the folded and space saving state, and the active being the unfolded, expanded state. Mollerup has, with this as a basis, created a set of rules which determine what is a true collapsible and what is not.

He states that true collapsibles use collapsibility as a support function of a tool, that the collapsibility must not be the most important function of the tool, although it can still be the decisive factor in a purchase situation.

In the case of a collapsible chair, this can be interpreted as though the main functions of the chair should be to offer proper seating and storing, and that the collapsibility is a support function to fulfill these main functions.

Mollerup also states that true collapsibles must be able to collapse repeatedly, meaning that products that unfold only once from its collapsed state does not qualify. The collapsing process also can't require mechanical assembly of any kind.

Mollerup also addresses stackability. He states that stackability in itself is not collapsibility, although a collapsible might be stackable in addition to being collapsible.

An adjustable or concealable product does not constitute collapsibility either as these functions are not designed to save space.

3.3.1. The twelve principles for collapsibility

Mollerup classifies different types of collapsibility in a framework he calls 'Twelve collapsibility principles'. See Figure 10.

Stress

The stress principle consists of compression and expansion through pressure and tension.

Stress-pressure means that the compressed state is for storage and the relaxed is for action. Mollerup gives a sleeping bag as an example product.

Stress-tension is the opposite, the stressed state is for action while the relaxed is for storage. Mollerup exemplifies with an elastic strap. This principle work with materials that have some degree of inherent flexibility.

Folding

Folding is one of the most common principles of collapsibility, it requires a soft or partly soft material such as textile, rubber, paper or similar. An example of folding can be the easy folding of a napkin.

Creasing

Creasing is similar to folding but differs since it only take place along predefined paths, or creases. Just as with folding this principle works with materials such as textiles, paper, plastic et cetera.

Bellows

Bellows is a lung-like collapsibility principle, represented in blacksmiths bellows. Airport gates that unfold over the airplane door also follow this principle.

Assembling

Assembling collapsibles can be seen in products which consists of several details which are in the passive state connected to each other but connects in more places in the active state. Tent pins which are connected with an elastic string are a good example of assembling collapsibles.

They are in the passive state only connected by the string, enabling them to be stacked together to save space. In the active state they additionally connect with each other to form a new structure.

Hinging

Connection of parts using flexible joints or different types of normal hinges, such as the ones used in piano lids and doors et cetera. This category also include single part flexible plastic hinges.

Rolling

Rolling as a collapsibility principle means that a product is reduced in size by being rolled up, a clear example of this can be found in camping carrymats.

Sliding

Sliding means that a product is reduced in size by parts sliding into each other. An example of this is a telescope fishing pole.

Nesting

Nesting products are collapsed by putting their parts inside or next to each other, using their overlapping or

cavities to save space. An example of this are series of coffee-tables which due to their different sizes fit on top of each other to save space.

Inflation

Inflation as a collapsibility principle is used for closed geometries which can be inflated with different gases, liquids or other substanses to expand into their active state. Inflatable travel mattresses are clear examples of this principle.

Fanning

Fanning means that a product's parts are rotated out from a centre axis to create the expanded active state. Examples of this can be found in candle holders or Japanese hand fans.

Concertina

The concertina is simliar to the bellows principle with the difference that it folds out in straighter manner, being able to expand both sides equally. A typical example of this is a musical accordion.

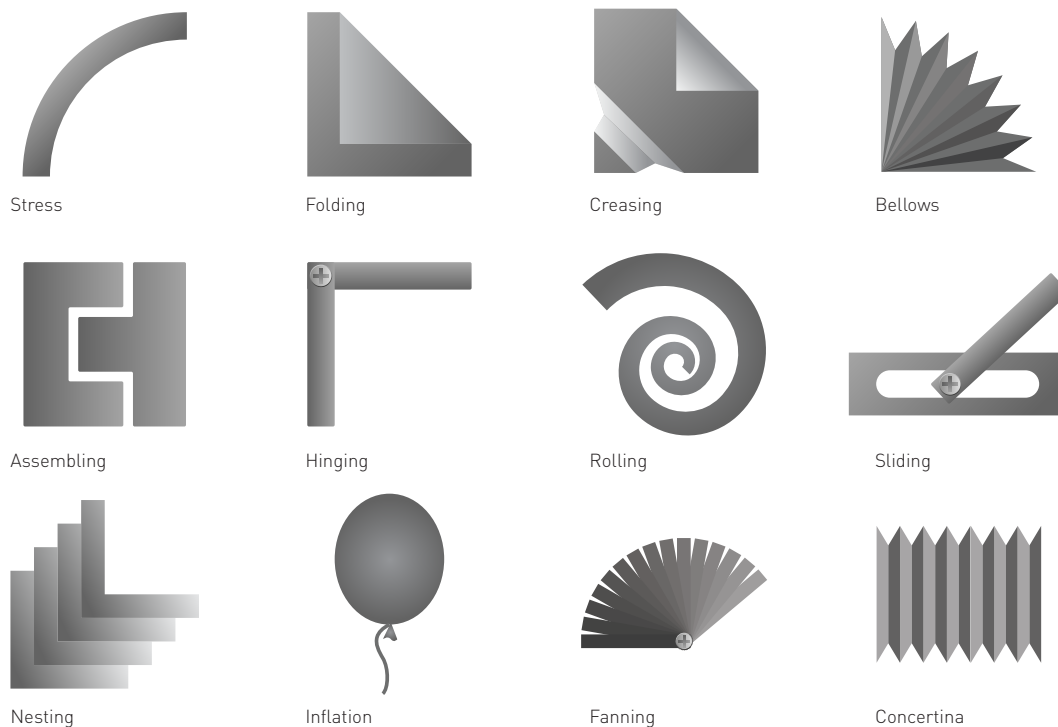

Figure 10. Mollerup's twelve principles of collapsibility

3.4. Novelty in the furniture field

In the furniture business, the main channels to the market are the big fairs and exhibitions. At these fairs, thousands of new products are shown every year, yet only a handful catch the attention of media and buyers and become successful. There are a number of different ways to get noticed, but the main argument is that the product must feature something new. The novelty can be represented in many ways, but the most clear ways to create novelty is through the form language, the material or the manufacturing process.

An example of a novel product is the chair Sting which was launched in 2003 by Blå Station. Sting was the first chair to feature a seat and backrest produced using aluminium extrusion. The designers behind the chair, Stefan Borselius and Fredrik Mattson, went around and visited a large number of manufacturers operating in different fields until they found the new and interesting process used in Sting. Johan Lindau at Blå Station puts a name on this method of making study visits, namely “Eriksgata”.⁴

Another example is the lamp W101 by Claesson Koivisto Rune. It received a lot of attention due to its use of the novel material Durapulp, a paper/bio plastics composite developed by paper manufacturer Södra. See Figure 11.

A product that stands out from the rest in respect of for example design, new materials or production techniques gets more space and attention in these crowded channels. The mentioned factors should therefore be considered during the development of the collapsible chair. Scientists have tried to define this phenomenon of experienced novelty, below follows a summary of some of the most interesting theories.

3.4.1. Most advanced, yet acceptable

While people have always been comfortable in choosing the most typical and familiar aesthetics, the safe choice, we are also enticed by the notion of the new and unfamiliar as a means to overcome boredom and similar effects. (Hekkert 2006)

Raymond Loewy (1951) proved that these two seemingly incompatible behaviour types both are instrumental when it comes to our appreciation of products. He summarizes his findings in the MAYA-principle; Most Advanced, Yet Acceptable. This means that it is possible to maintain familiarity while at the same time increasing the novelty of a product. Users tend to prefer products with a perfect combination of the two.



Figure 11. Claesson Koivisto Rune's Durapulp lamp W101

⁴ Johan Lindau (CEO Blå Station) Interviewed on the 12th of february 2011 at Stockholm Furniture Fare

3.4.2. Maximum effect for minimum means

Hekkert (2006) also argues that we tend to be conservative with our resources, that we prefer a smaller load on our senses when experiencing something impressive or breathtaking. To quote Hekkert; 'a theory or formula is considered beautiful when it only has a few assumptions or parameters that can describe or predict a vast range of phenomena'. This behaviour can be connected to the furniture field when looking at appreciated products. The most appreciated products are often simple, but with a hint of something clever that makes sense to the user - the sensory perception is not highly loaded but the aha-experience is still massive. (Hekkert 2006)

This principle is very similar to Johan Lindaus approach to design. His approach is all about finding the right idea and then reduce, reduce, reduce it until only the absolute essentials remain - "like making soup".⁴

3.4.3. Unity in variety

In our daily lives, we are subject to an overload of information. As our brains have limited capacity we can not perceive all this information at the same time, instead we try to find the meaningful information by grouping and sorting mechanisms. It allows us to locate relationships and wholes to make sense of the chaotic information around us, we try to find unity in variety. These ways to lessen the load can be reinforced by designing products with functions and visual cues according to the gestalt laws of symmetry, good continuation and closure. (Hekkert 2006)

3.5. Semantic aspects

Semantic's is the study of meaning. This section describes Gestalt theory and Monö's (1997) semantic design principles.

3.5.1. Gestalt

The gestalt laws are a set a rules formulated by German scientists in the 1920s. They explain how we organise and group visual information to create 'unified wholes' of it. Rune Monö (1997) describes gestalt as "a whole

which is more than the sum of its parts". This means that what we perceive is made up of a combination of colours, materials and parts, organised together to create a whole. Modifying any of these parameters results in a redefined gestalt, and with it a different perception of the product. (Monö 1997)

Monö lists the most important of factors that help us distinguish the gestalt. These are listed and explained below.

The proximity factor

The closer objects are to each other, the clearer the gestalt. Grouping objects that belong together in a close packing helps the user to distinguish the intended relationships easier. In Figure 12 we can see an example of proximity. (Monö 1997)

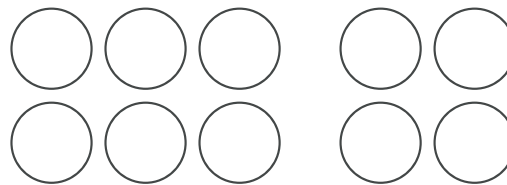

Figure 12. Proximity

The similarity factor

Objects that have the same visual properties stand out and create gestalts. This fact gives the designer a tool to group related objects using colour, shape or material without regard to proximity. As seen in Figure 13, relationships can clearly be seen between the circles even though they are not closest to each other. (Monö 1997)

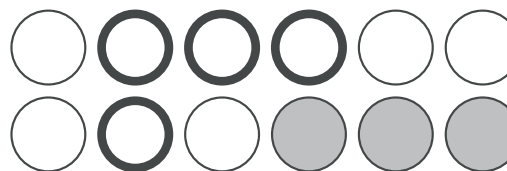

Figure 13. Similarity

The area factor

The smaller an enclosed area is, the clearer the gestalt become. Dark or light area makes no difference. A clear example of this is the flag in Figure 14. We see a grey cross on a dark background, not four dark squares on a grey background. (Monö 1997)



Figure 14. Area

The symmetry factor

Organizing objects symmetrically is a good way to create a gestalt. When looking at Figure 15, we can clearly see that the symmetric lines in the middle belong together. (Monö 1997)



Figure 15. Symmetry

The inclusion factor

Lines that enclose an area are more easily seen as a whole. The lines in Figure 16 are four identical lines repeated, when they are connected, they form a gestalt. (Monö 1997)

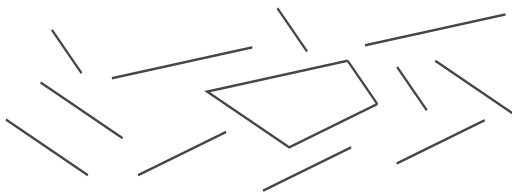

Figure 16. Inclusion

'The good curve' or the common determining factor

Help us catch the gestalt by grouping objects with continuity. As seen in Figure 17, there are four lines standing out as a whole because of their ordering relationship. (Monö 1997)



Figure 17. 'The good curve'

The common movement factor

Objects that move with similar speed in the same direction stand out to create a gestalt. (Monö 1997)

The closure factor

Familiar objects that have some part or section missing can still be seen as a whole. The observers' mind fills in the blanks.

It is also possible for us to see objects which are not actually there because of the gestalt created by the surrounding objects. In Figure 18, one can easily distinguish a triangle between the circles, even though the triangle is not actually there. (Monö 1997)

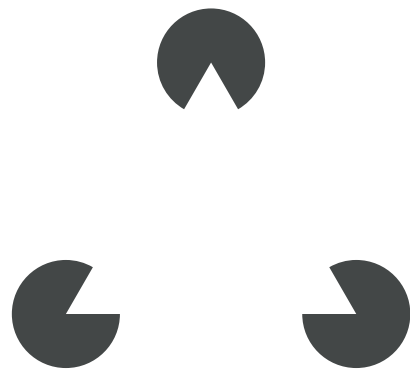

Figure 18. Closure

3.5.2. Semantic principles

Semantics is the study of meaning, it can be applied to product design in just that sense; what does a design mean to a user? The old saying “Form follows function” is not enough any more, the form must also explain and exhort the functionality.

Monö (1997) describes semantics as a tool for making the user experience product pleasure by enabling her to understand the product. Monö states that it is important for product designers to be aware of what is to be understood, what the product must express to the user.

Monö also describes a number of semantic functions which help designers to control what meaning is expressed through the product.

Describe

The product must describe what it's purpose and meaning is to the user. In the case of a chair, the product must clearly show the user that it's purpose is to provide seating. The chair should also describe itself as a collapsible chair, even though this should be a support function. The chair should also describe how it functions, the user should be guided by the form design in how to operate the product. This can be done by visually grouping contact surfaces or important functional elements et cetera.

Express

The properties of a product must be expressed through the form design. Is it a cheap or expensive chair? Is it safe? Monö exemplifies with different car models. They all consist of four wheels and a chassi, but they all express different things. Some express speed and performance, some safety or intelligence.

Exhort

The product should send signals to the user. These signals can be connected to safety, such as ‘do not put your fingers here’ or they can be connected to functions e.g. ‘pull this lever’.

Identify

The product should identify itself as belonging to a product group or brand. This can be done using form language, logotypes et cetera.

3.6. Visual brand identity

To make sure that a product communicates the right values to the user and that the user can recognise the product belonging to the right brand, theory from the field of visual brand identity can be studied.

3.6.1. Core Values

When looking at Shannon & Weaver's (Monö 1997) model of communication (See Figure 19), we can see that the product is the bearer of all the messages the brand want to convey to the user, but the product is not only the bearer of the message, it is the message itself. This means that all brands who design products convey messages bearing so called core values to the users.

These values are representations of what the user experiences when she perceives the product. In a perfect world, there would be no noise between company-product-user, and the perceived message would be identical to the intended. In the real world though, as we can see in Shannon & Weaver's (Monö 1997) model of communication, noise appears between the actors which means that the companies have to work hard with strategic core value based design to reduce risks of noise appearing in the messages.

3.6.2. Brand Essence

In todays crowded marketplace it is more important than ever to be seen and to be aware of what one's brand communicates. This communication can be summarised as the Brand Essence, and is something that can be worked with strategically by companies to control what they communicate to the customers. Karjalainen (2009) quote Nokia Siemens; "Our brand essence encompasses everything we do and all we stand for. It shapes how we think, speak and act."

3.6.3. Visual Brand Recognition

As a result of this the creation and management of a brand identity is an important marketing tool for a company of today. By designing recognisable products, brands can become strong and unmistakable (Karjalainen 2007). By being consistent in the brand communication, the brand becomes clearer to the user and is therefore easier to differentiate in the marketplace, a key success factor.

If a new product is recognised as belonging to a certain brand, all values connected to that brand is instantly loaded into the users perception of the product. If the user for example have had a product of the same brand that had a good build quality, the user will assume that these properties apply to the new product as well.

The brand recognition can be achieved using advertising or through recognisable logotypes, but the most effective and important one is product design.

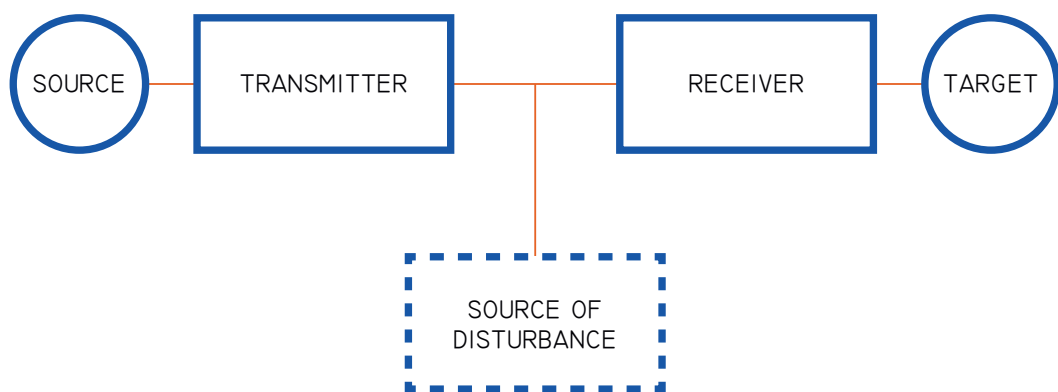

Figure 19. Shannon & Weaver's model of communication

(Schmitt and Simonson, 1997; Stompff, 2003 via Karjalainen and Snelders 2010). When designing a product, the designers can re-use recognisable design cues from previous products. Doing this can create instantly recognisable products.

Karjalainen lists two steps to creating and maintaining a strong and positive brand recognition; The first step is quite simple, to start off your positive brand recognition you need to design visually prominent and attractive products. The second step is to work strategically to fill your brand communication with positive values and meaning connected to a positive identity. (Karjalainen 2007)

3.6.4. Visual Design Cues

Value based vs. Artificial

When designing products, designers have a lot of form features to choose from. The shapes, colours, textures, logotypes et cetera can be combined in millions of ways to form an attractive product. It is up to

the designer to work strategically here to make sure that the design features communicate the right values and meaning. If a design feature does connect to the brand's core values, it is called a value based design cue. Karjalainen (2007) gives BMW's strong and dynamic form language as an example of a value based design cue since it is well connected to the brand's "ultimate driving machine" slogan.

A visual design cue that does not connect to the core values is called an artificial design cue. Even if it does not convey the brand message and values, it can still be a highly recognisable product feature. Once again Karjalainen (2007) gives us a good example, he states that while the BMW kidney shaped grille is a "powerful sign of recognition", it does not directly relate to the values of the brand. See Figure 20.



Figure 20. BMW's kidney shaped grille.
- An artificial visual design cue

Explicit vs Implicit

Visual design cues can be divided into two categories, the explicit and the implicit. The explicit cues are specific design features that can be repeated from product to product. They can be directly interpreted and recognised as they always are connected to physical features. A good example of an explicit design cue is Saabs Hockey Stick C-pillar. See Figure 21.

A visual design cue re-used in almost all Saab models.

When we experience products the impression we get from the product is more than just the parts. We interpret the shapes and the form language and read more into the product than only the explicit cues. What we call “design philosophy” is made up of the so called implicit visual design cues. These cues are not directly readable, but is perceived as a sum of the whole expression of the product, and since they always tell us something, these cues must always be value based. If not, the communication of the brand message gets clouded and unclear.

An example of an implicit and value based visual design cue can be found in Swedish Yoghurt brand Yoggi’s diet products. The graphic language of the packaging of the diet product compared to the regular, has been lightened up. The colours are brighter and the composition is more sparse. Together creating a sense of lightness, which goes well along the core values of the diet product. See Figure 22.



Figure 21. Saabs recognisable Hockey Stick. - An explicit cue



Figure 22. Yoggi Mini yoghurt packaging

3.7. Ergonomics

To ensure that a product fits the users needs, theory concerning both physical and cognitive ergonomics can be studied.

3.7.1. Physical ergonomics

When it comes to designing temporary chairs, seating ergonomics is usually not a high priority. This because the chairs are not intended for long term usage or for office work, the functions of easy storage and handling is considered more important. The important collapsibility of the chairs also often rule out thick comfortable seating and body-following ergonomic shapes.

The development of the chair in this project will try to consider ergonomic seating as much as possible, although it will not be the main focus of the project. Measurements and functions will be based on anthropometric research to fit as many users as possible and the angles and textures of contact surfaces and adjustability spans will follow ergonomic guidelines to an as large extent as possible.

Seating ergonomics

The act of seating can be viewed in different ways. Branton (1969) states "seating is only a means to and end rather than an end in itself". This meaning that there always is a reason for sitting down and that this reason should be the main focus of a chair designer. The seating itself should be made into a non-aware act. Of course this is very hard to achieve, but having it in mind when addressing the ergonomics, one might get results along the right path.

When the human body sits down, 75% of the body weight is supported by the ischial tuberosities, which are the bones located on the bottom of the pelvic girdle, and soft tissue surrounding it. This means that on a relatively hard seat, there is a high load on a small area of the body. If the seat is softer, the seat area connecting to the body is bigger, thus spreading the load better.

Anthropometrics

Rather than using mean values, which describe a singular person that does not exist, one should target a big group of the population. It is common to target the 5th to the 95th percentile (P5 & P95). By doing this, 90% of the population is covered.

3.7.2. Cognitive Ergonomics

In addition to the physical ergonomics of the user, the more abstract field of cognitive ergonomics can be studied. This can enable intuitive interaction between the user and product.

Mental Models

When trying to design a product which has functions that require some kind of user interaction, it can be useful to investigate the mental model of the users. The mental model is the user's own image of how a task is performed or how a system works. The mental model can vary in complexity depending on the task and is therefore extracted using different methods such as interviews or observations. (Gentner, D. Stevens, A L. 1983)

Having knowledge of how the users imagine that a task should be performed is very handy for a designer since it enables her to design the interaction in a way that is intuitively interpreted by the user. In the case of a collapsible chair, this can be beneficial. If the project group knows how the users want to collapse the chair, it can be designed to function in that very way.

3.8. Fields of interest

A number of interesting fields within product design were analysed to see what applications they could have in the design process of a collapsible chair.

3.8.1. Mass Customization

Mass customization has become increasingly popular in the last couple of years. The reason for this is the business opportunity it offers, to give the customer exactly what she wants and at the same time cutting out the middle man to increase the income of the own company.

Mass customization started largely in food distribution companies, where customers would be able to mix their own cereal or choosing what to put into their candy bars. Now its branching out to reach new markets with bigger products such as bicycles and furniture.

The freedom of the customization can be limited to offering a selection of different parts, such as choosing a different coloured interior for your car or specifying a different material for the legs of a table. It can also be widened, allowing users to specify patterns or modify existing designs and shape after their liking. Swedish design lab Front has developed a conceptual process where they use three dimensional tracking techniques to sketch a piece of furniture in thin air. The piece is then 3D-printed to fit the users sketch.

Using flexible machines and CAM-processes such as 3D-printing, CNC milling or Laser-cutting, customized products can be manufactured with quick responsiveness and at costs similar to normal mass produced products. Giving users access to online design tools could enable quick design changes which only marginally will impact on the lead times of producers.

3.8.2. Biomimicry

Looking into the field of Biomimicry can spark ideas and give solutions in many cases. The frontrunners of the Biomimicry movement state that nature has had 3.8 billion years of research and development and does therefore have the solutions to most problems.

A fact is that nature creates very efficient and ingenious solutions to quite advanced problems, solutions that differ majorly from how we humans would have approached the very same problem. The human way of creating things is normally to start with something big, then smash it, carve and pressure it with energy until it yields into a small product with a lot of waste. Nature on the other hand starts with very little energy and something really small and grows it bigger and more capable with no waste in the process.

This fact comes in handy when looking at design of collapsibles as they too have a compact starting state and then become bigger in some way. Nature has many solutions to this problem, one can look at birds wings, the unfolding of flowers to maximize energy absorption and the roll-unfolding of fern plants.

3.8.3. Integrated materials

Integrated materials describe single pieces of material which has been built up using several different materials or single material compositions.

This could mean 3D-printing a stiff beam with a softer material or structure integrated in the middle to create a joint with no moving parts. By creating parts like this, geometries can be achieved which would not be viable using standard mechanical assembly methods.

Mixing different materials can lead to difficulties in recycling processes and this is of course something that must be considered when choosing which materials to merge. One alternative to mixing materials is to create parts made up of a single material but with different structural compositions, resulting in variable flexibility within a detail.

3.8.4. Origami

A field closely connected to collapsibility is the art of Origami, paper folding. It has influenced designers in different fields, ranging from airbags to aeronautic equipment and packaging design. The art of origami has also been used extensively by NASA when trying to figure out how to unfold satellite's solar panels in outer space.



4. Methods

This chapter describes the theory behind the methodology used in the project. It covers areas such as information gathering and creative methods for ideation.

4.1. Information gathering methods

To extract all requirements and needs associated with one's product, data can be collected using the following methods.

4.1.1. Interviews & Consultations

By performing interviews and consultations with key persons the framework and requirements of a product development project can be set. Every discussion concerning the project can be scrutinised for valuable data and information that can be used as a basis for the design process.

Interviews can be structured, following a strict template sheet, or unstructured, letting the interviewer expand on topics of interest that appear during the interview. (Johannesson et.al. 2004)

4.1.2. Literature review

To further specify the problem and to gather the required knowledge for the product development

process, literature studies can be performed. The sources of information most often consist of published articles and other scientific publications which can be found in printed editions or through scientific databases online.

The collected data helps to clarify measurable demands but can also contain general information about a certain field.

4.1.3. Study visits

Studying literature can give a lot of information about how products are produced and what complications might occur during a development phase. However, to gain complete knowledge of what the most common problems and design guidelines are for a specific material or process, it can be rewarding to conduct study visits to plants and manufacturers.

When visiting the industries and maybe most importantly talking to the people working there, common mistakes done by the designer can be avoided and production cost can be minimized. The discussions can also

result in novel ways of utilizing the processes and materials as the designer contributes with a different view of how things could be made. Challenging the often quite conservative industries pushes the development forward and results in new materials and applications. Also, getting to know key contacts at the industries make future collaboration easier and creates a bank of people to ask as questions arise.

4.1.4. Fairs

Visiting fairs can be a good way to gain knowledge of the most evolved fields within a certain sector. As the fairs is one of the most important marketing grounds within the furniture field, all the latest inventions in materials, manufacturing and design is gathered in one place.

4.1.5. Design format analysis (DFA)

To identify the important visual design cues that make up a brands visual identity, a Design Format Analysis can be performed. The method helps to find characteristic elements which can be reused when developing a new product which need to fit into a company's portfolio or in a product family.

The first step in the DFA process is to look at the portfolio and identify the most characteristic elements of each product. These elements are then ranked according to their importance to the products visual appearance. The elements are also analysed individually to create an understanding of how typical they are over the whole portfolio or product line. The result of the method is a list of which design cues are the most typical and recognisable for the portfolio. (Warell 2006)

4.1.6. List of functions

To condense all gathered user demands into an ideation process, a list of functions can be established. The list is created by defining the product's main function and breaking it down into subfunctions which the final concept should feature. These subfunctions are often abstractions of the measurable demands that can be found in the specification of requirements. A normal approach is to formulate every functional demand in the form of [verb] [noun]. E.g. 'support weight', 'withstand pressure'. These subfunctions can then be used as foundations in other parts of the product development process, an example can be to use them in a morphological matrix. (Johannesson et.al. 2004)

4.1.7. Specification of requirements

A specification of requirements states which demands are being made on the future product, this can address everything that the product should fulfill; user demands, functional demands, durability demands and performance demands. The specification is often a result of the pre-study, all the properties of the product are determined based on the results of other methods such as the list of functions. The specification fully describes all demands and often features measurable values of the previously abstract demand. E.g. 'support weight up to 100kg'.

The demands are sorted into two categories, demands and wishes. The demands must be completely fulfilled while the wishes can be partly fulfilled. The specification can also be weighted to clarify the severity of certain requirements.

4.2. Ideation & Evaluation methods

When the analysis phase has been completed, the information is used as a basis for creative ideation. The ideas created are then subjected to evaluation methods.

4.2.1. Mood Boards

A mood board is a collage of images used to assist analysis, creativity and ideation in a design process. It gives the designers a chance to, at an early stage, visualise their perceptions of a future product in a way that helps address both problem finding and problem solving in later stages of the process (Garner et al 2002). The mood board helps to set a common project goal and is a good mean to make sure that the right perception values are present throughout the entire product design process.

4.2.2. Brainstorming

Brainstorming is a method which can be used on many levels and at many different stages of the product development process. This mainly because it is a simple method with the goal of finding new ideas and directions of thought. This said, the most usual application is when a big number of ideas must be generated with the list of functions and specification of requirements as a basis.

The method is conducted by letting a group of people think and discuss freely to find as many ideas as possible, no matter the level of realism. The word and thought should be set free to get creative ideas and innovative solutions on the problems at hand. Critique or deeper analysis of the ideas should not be permitted during the session, this to encourage the group to go further outside the box.

It is important to have a secretary who records all the ideas and leads the session on if the process should slow down.

The brainstorming sessions normally result in a number of ideas that can be worked and analysed further using other methods such as a morphological matrix. (Johannesson et.al. 2004)

4.2.3. Morphological matrix

A morphological matrix is used to give prospects and ideas of possible concepts in the ideation process. A matrix is created using subfunctions from the list of functions or from ideas. These are then used to generate subfunctional solutions. These solutions are combined with each other within the matrix to create a number of total solutions. Some degree of sorting is then used to rule out the ones which are irrational or does not fulfill enough of the set demands.

The purpose of the method is to condense a number of these total solutions which fulfill all of the product demands and requirements.

4.2.4. Focus Group

A focus group is a group of users who are invited to interact or discuss a number of products or concepts. The focus group can be used to gather different types of data in various stages of the product development process. The participants are typically asked to discuss a certain topic or interact with a representation of a product. The groups activities are recorded and later processed to extract both spoken and unspoken data. It is also recommended to have a moderator who can guide the participants and keep the group going. (UPA 2011)

In the project described in this report, the focus group was used at the ideation stage.

4.2.5. Sketching and visualizations

In the development of a product it is important to in a good way be able to communicate and test ideas. In order to quickly visualize a concept, two dimensional sketches or three dimensional mock-ups are valuable methods of visualisation. Sketches are often the first step in this process as all one need is a pen and a paper.

The sketches can be used throughout the process as ideas are developed and new concepts are generated. The quality of sketches can vary, from simple line-drawings to more elaborate rendering using for example markers. Often, seeing an image is much easier to comprehend than reading a description of it (Karlsson, 2007).

4.2.6. Computer Aided Design

CAD (Computer Aided Design) is a tool used to quickly build and simulate objects or products. It is a relatively fast way to test ideas and get a feel for how they behave and look in 3D-space. There are many types of software for CAD and they can all be used for different types of modeling. Common to them all is that one quickly can create renderings to see how the product looks with different materials and in different contexts.

4.2.7. Physical models

Sketching may be the designers most important tool but it can be difficult, even for the most experienced designer, to imagine the sketched product in real life. By building quick models out of simple materials, designers can get a sense for the scale and proportions of the product. (See Figure 23) This understanding can be very important to gain before taking the design to the next level where changes might be much more costly in time and funds. These quick models are often called mock-ups (UPA 2011)

At later stages in the process, more intricate models, or prototypes, can be created to verify the design. These can be used for evaluations and adaptations to mass production processes. (Johannesson et al. 2004)

4.2.8. Pugh matrix

When a number of early concepts have been developed, it can be good to use a pugh matrix as a helping tool to choose which to develop further.

The pugh matrix compare the different concepts to a reference. This reference can be an existing product or a basic idea solution. The concepts are graded according to how much better or worse they solve the functional demands compared to the reference. It is important to use the weighting values from earlier in the process to get validity in the evaluation.

With the pugh matrix evaluation as a base a number of concepts can be chosen for further development. (Johannesson et.al. 2004)

4.2.9. Design for assembly (DFA)

Design for assembly is a technique used to facilitate easier manufacturing and assembling of product, this by considering and simplifying all steps of manufacturing.

In the furniture field, it is common that a number of specialised manufacturers are involved in different parts of the product. The parts are then sent to the designing company where they are assembled using simpler methods. This facilitates easy combination of different details to customise the products per order. It also keeps the order sizes steady, which is economically beneficial for the designing companies.

When a piece of furniture is to be repaired or have a part replaced, it is also common that this is done by the designing companies rather than the subcontracted manufacturer.⁵

Keeping this in mind, designing for assembly and disassembly is important. The main parts should be possible to assemble at the designing company using simpler tools. This rules out things like welding both sides of a joint shut. (Lefteri 2007)

Figure 23. Physical models can give the designer a sense of scale and proportion



⁵ Johan Lindau (CEO Blå Station) Discussion at 10th of May 2011, Åhus

5. Results

This chapter describes the theoretical results gathered during the analysis phase of the project. It presents the findings gathered from literature, interviews and study visits.

5.1. Literature

Literature was used continuously during the project. Methods where investigated, information of manufacturing techniques and materials was sought and valuable information of Blå station and the furniture industry was found. Literature describing furniture design of today and the past was studied, interesting design was reviewed and condensed to key sentences which could be used in the ideation process.

Fields such as ergonomics, temporary architecture, mass customisation, biomimicry and origami were looked into. A number of design theories were also studied and a framework for collapsibility was discovered. This framework was later used throughout the ideation process to encourage structured thinking.

The design community was studied through non-conventional media such as blogs and other websites. It turned out to be a good source of newsworthy information about trends, new processes and materials which had not yet been covered in the conventional publications. A lot of inspirational images and data was collected from these studies.

5.2. Interviews

Interviews of varying kind is a key method for the development of Applåd. Interviewing representatives of manufacturing industries to find the most economical way of producing, interviewing project tutors Johan Lindau and Ulrike Rahe to get an professional view on the design. All of these more or less planned interviews guide the project group to achieve an as optimal design as possible.

To complement the face to face interviews during study visits and presentations of the progress made, telephone interviews has been conducted with among others; Johan Lindau, Niklas Åberg of NÅ Formtextil and Magnus Weinbach of Bending group.

The interviews were recorded by hand notes or audio recordings and often summarized in a short text for communication within the project group and to create a reminder for later stages of the project.

5.3. Visits to furniture fairs

Two big furniture fairs were attended, the Milano Design Week and the Stockholm furniture and light fair. (See Figure 24)

The Milan fair is considered to be one of the biggest and most important furniture fairs in the world. The Stockholm fair is considerably smaller but is still one of the most influential fairs in the Nordic countries.

Attending the fairs and meeting professionals and designers from the furniture field gave valuable insight in how the furniture industry works and acts, as well as an update on where the trends are going. Especially the Milano Design Week & il Salone with its diversity and broad coverage of the design field worked as a great source of inspiration.

A large amount of inspirational data was gathered through photographs and collection of hand out materials.

5.4. Condensing inspirational data into Morphological Innovative Spur Sentences

When developing innovative ideas, it is beneficial to have some kind of inspiration or basis to ideate from. The Morphological Innovative Spur Sentences method was developed by the project group as a way to condense key design features into something more abstract. In this way, the inspirational part could be sustained and the risk of copying physical features minimized.

The visits to Stockholm's and Milan's furniture fairs resulted in a large amount of photographs capturing the most innovative and interesting furniture



Figure 24. A great deal of inspiration was gained from visiting the fairs

solutions and details. These were put together with an equally big amount of images gathered from books and websites.

The most interesting features were selected and analysed with the aim of producing neutral sentences that captured the essence of the interesting aspects without trying to copy the solution. The sentences were produced within four categories; *Look / Expression, Technique, Method, Material.*

Look / Expression

This category would describe something visually enticing. Some examples were:

“Open ended pipe create a light look.”
“Interestingly subtle.” (See Figure 25)



Figure 25. 'Plytube' by Seongyong Lee.
A stool made from rolled veneer, assigned an expression spur:
“Open ended pipe create a light look”

Figure 26. Two leg table by Ben Klinger and Shay Carmon.
Assigned a technique spur : Unexpected leg direction



Technique

This category would describe a functional solution which added innovative value to the product. A few examples were: “Unexpected leg direction.” “Objects draped in elastic textile.” “Origami flower-folding.” (See Figure 26)

Method

This category described visually detectable manufacturing methods which added to the interesting and innovative values.

“Sandwiching layers.” “Metal sheet blowing.” “Textile hinges.” “Metal skeleton dressed with other material.” (See Figure 27)

Material

The last category, Material, captured both new and old materials that was used in an innovative way, some examples were:

“Steel plates.” “Polyethylene + Glass fibre.” “DuraPulp.” “Honeycomb paper.” “Metal thread structure.” “Ropes.” (See Figure 28)

5.4.1. Application of the method

These sentences could then be used, either just as loose sentences or combined in a morphological matrix, as idea spurs in conventional ideation methods. They were used by the project group in several applications. One of them a brainstorming session where a structured approach was tested. Each project member selected a few spurs at random and tried to come up with ideas based on them.

The method was also used as part of a group ideation session. All the sentences were printed out on small strips of paper. The sentences were colour coded according to which category they originated from. Each member of the session group was then randomly assigned one sentence from each category. They were asked to take inspiration from these while brainstorming and sketching.

The spurs helped the group members to be creative and clearly proved to guide their ideas. This could be seen as each group members ideas could be connected to the spurs they had been given.



Figure 27. ‘Saari’ by Arper. Constructed by inserting metal tubes into wooden legs, resulting in a very light, yet permanent look. Assigned a method spur describing the manufacturing procedure; “Metal skeleton dressed with other material”

Figure 28. New material Durapulp by Södra. A composite material made from paper pulp and a bio degradable polymer. Assigned a material spur; “Durapulp”



5.5. Study visits

From the start of this project there was a strong wish to visit as many different industries as possible. By doing so, a deep understanding of the processes and materials can be formed. As a fresh pair of eyes is exposed to these impressions, novel ways of utilizing the materials and techniques can be found. It is also especially valuable for the designers in order to shape an as cost efficient and lean product as possible.

The companies and organizations visited were selected based on their available manufacturing techniques to ensure broadness in the results. In addition, interviews and consultations with manufacturing professionals and designers were conducted.

5.5.1. Elmo Leather, Svenljunga.

At Elmo leather in Svenljunga, premium quality cow hide leather is produced for usage in mainly car seating and furniture. The leather is available in different qualities and compositions. The most exclusive leather is the aniline. It is the softest and most natural leather; no additives are added to it except the dye. The only leather type which has no added dye is the Vegeta aniline, it comes only in one colour which is a very light, almost skin coloured, beige. See Figure 29

The reason all of the leather is dyed is a result of the tanning process. To get the leather clean enough it is tanned in trivalent chromium. This chemical process leaves a pale blue colour on all the hides which forces Elmo to dye them. The Vegeta aniline is tanned in another, mineral based, process which does not dye the leather but is not strong enough to clean all hides. Therefore only a select number of hides become Vegeta aniline.

Since the aniline leather is so raw, it is quite sensitive to moist and fat. Stains of this type can create discolouring and damage the leather. This might be acceptable for some products while others must withstand tougher handling. The way to handle this is to subject the leather to a polymer coating process. This creates more resistant leather that can be used in tougher settings. Elmo refers to this as semi-aniline or technical leather,

depending on how thick the polymer coating is.

One problem with the thickest coatings is that the natural pattern of the leather is lost. Elmo solves this by stamping a new pattern on top of the polymer coating, a little known fact which enables designers to put custom patterns into the leather.

A couple of questions were posed after the visit. One concerning the waste in the production process and what happened to it. Elmo demonstrated how they gathered the fat, hair and abrasive dust, and turned it into biogas. An idea here was to gather up the dust from the abrasive processing of the hides and try to press it into a chair component.

The study visit at Elmo also led to the idea of Miura origami leather, a method for pressing leather into origami patterns. The Miura leather is described in Appendix A.



Figure 29. A freshly tanned vegeta cow hide is trimmed

5.5.2. Stena Metall, Göteborg & Borås.

The study visit at Stena Metall was conducted in two parts. The first visit was made to the sorting station located in Hisingen, Göteborg. At the sorting station, waste is gathered from a multitude of sources, including industrial organizations such as Volvo and from municipalities and private households. See Figure 30.

The separable waste is sorted by material type and material purity, while the rest is shredded and shipped to the Halmstad facility by train. In Halmstad the sorting process continues.

The project group inquired about how steel tubes and chromium plated materials are handled since these are very common furniture materials. Stena Metall explained that the furniture waste they receive is in quite small batches which make it economically sound for them to shred it, sort it according to its composition, and send it to a foundry. The foundry melts the materials and makes new alloys from it.

Chromium plated steel for an example can become the basis for stainless steel alloys of different qualities.⁶

Something noteworthy with this visit was the small portion of the waste that Stena Metall could not sell. There was in fact some waste such as cable insulation plastics, which could not be sold today. It had residue of copper wire in it and was therefore not attractive to the recycled plastic market. The guide at the facility, Mats Tarring, described this process of finding a use for the waste as the most interesting challenge of his job

The project group also received tip of a product that uses a similar type of waste, old tires. Apokalyps lab in Malmö has invented a process which turns old tires into parquet-like floors.



Figure 30. Mixed steel waste is being sorted and shredded

⁶ Taina Flink (Stena Recycling) Email / Discussion. Fall 2011

5.5.3. SAPA group, Vetlanda.

Sapa group is one of the world leaders in extruding aluminium profiles. They produce a wide variety of parts and products for different companies, ranging from engine parts to jewellery. The process is quite simple and creates parts with a two dimensional cross section in lengths up to 6 meters. The profiles can then be machined and treated with various surfacing methods such as anodizing.

Sapa in Vetlanda has got a number of machines, mostly operating in the same fashion but with different size capabilities. The smallest producible details measure a few millimetres while the biggest ones can have dimensions of up to 400 mm.

Blå station has a chair called Sting which is produced by SAPA. It consists of two profiles which are put together using one of Sapa's suggested merging methods. The seating profile is pushing the limits of Sapa's production machines with its 399 mm but proved producible and received a number of awards and prizes for pushing the boundary of how big and thin an extruded piece of aluminium can be.

5.5.4. Porslinsfabriken Lidköping

Lidköping is a small city in the inland of Sweden, famous for its history of producing porcelain and stoneware. The manufacturing began in the 18th century and has gone on until a couple of years ago when the factory moved to Poland. A new company has started production in the old premises, producing stoneware and faience with both modern and traditional methods. The main production method is moulding; ceramic powder is mixed with water, stirred and poured into plaster moulds consisting of a number of parts. The mould is filled to the brim and is given a specific time to dry. When the ceramic liquid dries, it dries from the moulds inside and inwards, giving the craftsmen the ability to decide which wall thickness the detail will get. When sufficient time has passed, the part of the liquid which has not dried yet is removed from the mould, resulting in a hollow detail. (See Figure 31)

Figure 31. Piggy banks under production at Porslinsfabriken

The moulds are then separated and the detail is taken out for refinement. The detail is rubbed with a wet sponge until the visible moulding residue is removed. After this the detail can get different kinds of surface treatments/glazes, giving it different colours and textures.

5.5.5. Swedese

Swedese is a major Swedish furniture manufacturer who is mostly known for the Lamino chair. A lounge chair made from laminated wood bars with a saddle-girth seating draped in a sheepskin.

Both factory and office is located in Vaggeryd, Småland.

At the Vaggeryd factory, the project group was introduced to the manufacturing process for Lamino, learning about modern wood lamination techniques and also got a small briefing on how Swedese work with strategic product portfolio management.



5.5.6. Andrénplast, Göteborg

Andrénplast in Göteborg works with vacuum forming for a number of different clients. They can produce parts in almost every thermosetting plastic available. The different plastics used can have different finishes, lacquers and transparency to create a big range of looks for the finished part.

The first step of the process is to heat a sheet of plastic close to its melting point. Pressurized air is then used to semi-inflate the plastic in order to distribute the material evenly. After this, the plastic sheet is draped over a tool, usually machined from aluminium or ureol, to roughly shape the plastic. The next step is to activate suction through small holes inside the tool; this creates a vacuum that suck the plastic into its proper position. The plastic then cools and ends up as a rigid detail which can be removed from the tool.

When the shaping is done, the part is usually milled in a computer controlled milling machine (CNC) to get its final shape. For simpler shapes, the parts are often punched out of the shaping residue.

This process raised a question. Would it be possible to vacuum shape metal as well as plastic? Using higher temperatures and stronger tool materials? The inflating process also resulted in some ideas and questions. Could metal and plastic inflation shaping methods be used in furniture design?

After a bit of research, a company called Superform Aluminium was found. With branches in Great Britain and USA, Superform Aluminium has created a process for shaping aluminium plates using air pressure and heat. The plates are heated up to about 500 °C and are then forced into a tool using external air pressure. The method could not be found in Sweden but seemed fitting for production of all sizes needed for the production of a chair.

5.5.7. Bending Group

Bending group consist of two facilities in Småland, Sweden. The first visit was made to the one in Örsjö which mainly deals with bending steel tubes and wire.

The facility has three machines capable of different types of bending. Out of the three, only the newest machine is capable of bending the same tube in more than one direction, enabling more complex geometry. The newer machine also had the possibility to create multiple bends after each other without spacing while the older machines needed at least 50mm in between bends. The new machine was also able to create variable radius bends.

The company works with 12-38 mm Finnish steel tubing. The tubes are normally chrome-plated with trivalent chromium after bending to protect from corrosion and increase the durability/longevity.

The facility also operates a number of automatic and semi-automatic welding systems.

In addition, the facility has a brand new CNC-mill which today is used mainly for making tools, although it is also intended to partake in the manufacturing process.

Bending groups other plant, located in Nybro, handles wood bending. They are able to bend solid wood but mostly work with laminated products.

Beech and Birk are the most common woods used in the lamination process. A number of sheets are selected due to their quality (A, B or C) and are then usually rolled through glue rollers to get an even distribution of glue on both sides. Bending Group on the other hand, have developed a process including solid sheets of glue which melt in the pressing process step. This saves time and results in a cleaner workspace.

The sheets are placed in a press where they are forced together between two 80°C metal moulds. Microwave radiation is then used to dry to the glue and fixate the shape of the product. The drying process takes about 6-8 minutes.

The next step is to cut the product into its desired shape using CNC mills. The products are then normally varnished to increase the durability. Bending Group has developed another process where a sheet of melamine plastic is laminated on the top and bottom

side of the products. This results in a cheap and sturdy finish suitable for school furniture and similar subjected to high levels of wear and tear.

5.5.8. NÅ Formtextil

NÅ Formtextil is a company specialized in pressing and shaping felt. Form pressed felt was originally used in vehicle interiors to create a more exclusive look and feel while at the same time dampening noise to create a better environment in the cabin.

One of the first to use felt as a furnishing material was Stefan Borselius as he designed Peekaboo, a lounge chair from Blå station made from a steel frame with a pressed felt seating inlay.

The raw felt used for pressing consists of Polyester of which about 40% of the fibres has a lower melting temperature than the rest, working as a binder. They come in different thicknesses (weights) and compositions. The available colours are mainly limited to a grey scale. Mostly because of batch sizes and demand not being big enough to make it economical to mix new colours.

The processes of the shaping starts with sheets of felt being heated to about 160 degrees Celsius, this melts the 40% of the fibres with lower melting temperature within the material, enabling it to be shaped before cooling. The sheets are then pressed inside a mould tool with 5 to 10 tons of force. The felt is reduced in thickness with about 75 percent and is left to cool for about five minutes with the pressure still applied. The next step is to cut off the excess felt sticking out of the tool. This is either manually cut with a knife or, depending on the geometry, punch cut.

The pressing moulds are made from a variety of materials which depend on the geometry and series size of the product. A tool made from MDF is the cheapest and normally cost from 75 000 sek and upwards. The more exclusive tools are milled from aluminium or ureol and can cost around 500 000 sek. The more expensive tools last longer and give better tolerances.

The price of the manufacturing itself is not very dependent on the batch size since most of the work done in the plant is manual.

The process sets demands on the design of the product. It must follow normal pressing rules, e.g. draft angles are required. The drafts can possibly cross 90 degrees if the geometry and thickness allows the product to flex out of the tool.

A method developed by NÅ Formtextil for Blå Station is to drape the felt in textile. The fabric is glued to the felt in the same pressing that shape the product. (See Figure 32) This does not work with all geometries and is something that has to be tested in the prototype phase of a project.



Figure 32. Furniture textile is being cut to the right shape and size before the pressing procedure

5.6. Defining the user and context

The user of the Applåd chair is quite hard to define. This because of the previously mentioned division between actual end user, buyer and handler.

Since Blå Station only targets the professional sector, it can be assumed the most common environment for the chair would be offices, conference centers, airports, schools, universities or municipal buildings where there is a need for premium class collapsible chairs. This means that the end user can be any visitor to these areas. They can be of any age, even though the working population should be the most frequent visitors to these places.

As previously mentioned, the end user might not be the same person that installs/unfolds the chairs. This might be done by janitors or event personnel which has the installment of the chairs as a part of their daily job. This group of users should be considered when choosing the weight and functional properties of the chair as they are likely to be the most frequent handlers of the product.

With this in mind, the chair should be designed to fit a majority of the population with focus on the working population and the personnel that will handle the chairs.

5.7. Functional guides

In the strife to design a novel collapsible chair, a number of broad functional demands were listed. These would act as soft guides when entering the ideation process and in later stages of the process be treated more as demands that would influence the evaluation and choice of the concepts.

Main function:

Provide seating

- The chair's main purpose must be to provide seating just like any other chair. This concept includes that the chair is stable and correctly functional. The collapsibility should be seen as a bonus function.

Secondary main functions:

Be ergonomically unobtrusive

- The chair should in no way compromise the completion of the user's purpose for sitting down.

Provide easy and safe storage

- The chair should feature an easy and safe collapsing procedure so that the user can complete her task of storing it.

Wanted functions

Be easy to manufacture

- The chair should be as easy and cheap as possible to manufacture. This should be achieved through sound construction and production design.

Appear reliable

- The chair should not only provide functionally reliable seating, it should also be visually perceived as doing this.

Be adjustable

- It would be beneficial if the chair allowed for some kind of adjustment, this could consider different heights and angles that would act towards the overall comfort of the chair.

Be perceived as novel

- The chair should be perceived as novel by the user in some manner. It could be through the use of materials, processes or form design.

Use sustainable materials and processes

- The chair should over its different life cycle phases have as little environmental impact as possible.

Be stackable

- It would be profitable if the chair allows for some kind of space saving stacking in addition to the collapsing.

5.8. Anthropometric properties

Rather than using mean values, which describe a singular person that does not exist, one should target a big group of the population. It is common to target the 5th to the 95th percentile (P5 & P95). By doing this, 90% of the population is covered.

All anthropometric data in this report has been extracted from DINED.nl, a tool provided by TU Delft. The data used comes from the dutch population of 20–60 year old's and was collected 2004. The dutch data was used since it had the most complete data set available.

The most important measurements for the project are:

Buttock - popliteal depth

The dimension from the back side of the knee to the back side of the buttocks. See measurement A in Figure 33. The anthropometric database provides the following values: P5: 457mm, P95: 553mm.

This means that the chairs seat depth should be below 457 mm to fit the users.

Popliteal height

The dimension from the floor up to the horizontal sitting plane from the leg to the buttocks. See measurement B in Figure 33.

The anthropometric database gives us the following values: P5: 397mm, P95: 529mm

This means that the highest position of the upper side of the seat should be between 397 and 529 mm. Blå Station generally uses around 450mm for their chairs.

Elbow height

The dimension from the popliteal height to the bottom side of the elbow. See measurement C in Figure 33. The anthropometric database gives us the following values: P5: 203mm, P95: 301mm

This means that the armrest should be positioned between 203 and 301mm above the seat. Blå station normally uses around 220–230 mm.

Elbow - grip length

The dimension from the back side of the elbow to the grip of the hand. See measurement E in Figure 33.

The anthropometric database gives us the following values: P5: 297mm, P95: 385mm

This means that if the chair features an armrest that should be gripped, the gripping point should be positioned between 297 and 385mm from the backrest.

Hip breadth

The width between the outer sides of the hips when sitting down. See measurement F in Figure 33.

The anthropometric database gives us the following values: P5: 351 mm, P95: 447 mm.

Ergo, the chair seat should be at least 447mm broad to fit 95% of the population.

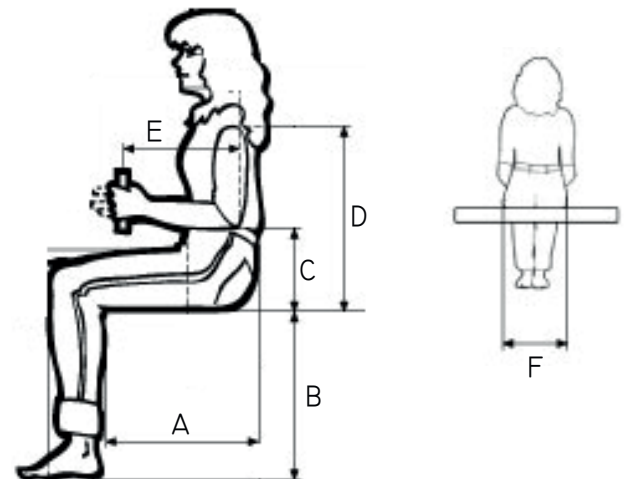

Figure 33. Anthropometric measurements

5.9. Mental models of collapsible chairs

During the project process, a general image of the users mental model for most chairs' typical collapsing procedure emerged. Almost all people who was spoken to or interviewed had the notion of that the proper way to collapse a chair is by putting one hand around the front end of the seat and the other around the top of the backrest and push them toward each other.

It was decided that a small user test should be conducted to establish the general mental model. A scale model of a chair was presented to 22 users and they were asked to collapse it. The users hand movements was observed and recorded during the collapsing process.

The results of the user test confirmed the previously mentioned general mental model. 18 Users, or 82%, tried to pull together the front of the seat with the top of the backrest. Two users grabbed the middle part of the legs and then changed their mind and grabbed the the seat and backrest. See the results vizualised Figure 34.

Two other users tried to grab the armrest to see if there was an "unlocking" mechanism. One of these users put the other hand on the backrest while the other user put it on the seat.

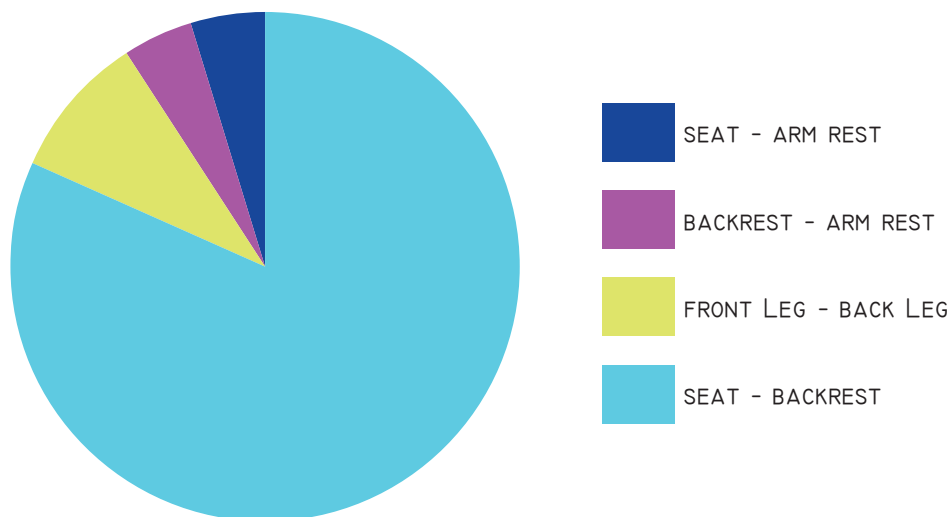

Figure 34. The Chart clearly shows that the Seat to Backrest mental model is the most common among the users.

5.10. Market positioning

When it comes to competitors, Blå Station has got a lot of them. Blå Station's business model is quite similar to most Swedish furniture brands, some of them are more specialized in certain materials but almost all work with the same approach of freelance designers and sub-manufacturers. As many of the brands work with the same designers, it is hard to pin-point Blå Station's position on the market. An attempt to find out how the people in the business felt about Blå Station in comparison to their competitors was made at the Stockholm Furniture Fair. Users were asked to sort different brands according to specific value words such as "reliable", "innovative", "curious" et cetera. Sadly, since there were so many competitors to sort, the survey took a lot of time which resulted in a too small number of users. The results from the study were therefore deemed to be unusable. See a description of the tool developed to gather the information in Appendix B.

5.11. Visual brand identity of Blå Station

As Börge Lindau founded Blå Station he had the idea of producing a rich and varied range of chairs, stools and tables based on the concept of round birch rings. (Blå Station's Homepage, Så började det, 2011) For many years to come this was the spine of Blå Station's visual brand identity and the form language based on birch rings and stainless steel was strongly associated with Blå Station for a long time. Their furniture were full of explicit and bold design recognisable cues. See Figure 35.

As more and more external designers were engaged and manufacturing techniques and materials were developed, their form language and hence visual brand identity evolved into a more abstract representation of their core values containing more implicit design cues than the explicit. The company made innovation their guiding star and that is what profiles them today, innovation and curiosity. See a sample of the explicit variety in Blå Station's current portfolio in Figure 36, Figure 37, Figure 38 & Figure 39.

Most of the Swedish furniture brands, including Blå Station, do not employ their own designers, they work together with them on a free lance, project-to-project basis.

This results in product portfolios which do not have very clear brand recognition since the designers usually design their furniture before they contact any specific brand. The designers also have personal styles and form language that they use in different products across multiple brand's portfolios.

To analyse the visual consistency of Blå Station's product portfolio, a Design Format Analysis was conducted. The DFA is useful when analyzing the visual design cues of a brand. In Blå Station's portfolio, groups of furniture visually closely related to each other was found. These product families within the portfolios are almost exclusively made by singular designers and have form design connected from their personal style.

Because of this effect, Blå Station's current portfolio does not have a lot of recognisable shared explicit visual

design cues. Although, their choice of products to feature in their portfolio have resulted in a number of visual implicit cues, such as a lightness and vivid use of colours. See the Design format analysis in Appendix H.

The DFA was useful for the project, mainly to familiarize the project group with Blå Station's product portfolio but also to establish the lack of visual cohesiveness. Building from this, it was clear that the Applåd design would not have to feature any recognisable visual explicit cues from Blå Station's heritage. Instead, focus would have to be placed on creating strong implicit cues, springing from the core values of Blå Station.



Figure 35. The classic 'Hövding B8L' by Börge Lindau from 1986 is a good example of Blå Station's traditional cohesive visual identity.



Figure 36. Chair 69 designed 2005 by Fredrik Mattson.



Figure 37. Spook designed 2011 by Berlin / Iskos.



Figure 38. Latte designed 2010 by Tomoyuki Matsuda.



Figure 39. Oppo designed 2009 by Stefan Borselius.

5.12. Core values of the Applåd chair

Before the creative process was started, a number of core values were defined to represent what the Applåd chair should communicate to the users. These values were developed with Blå Station's Implicit values in mind, such as clarity, lightness and innovation. They serve as a basis for all the communication that the Applåd chair will express and should be present at all steps of the product development process.

Thorough

The product should be constructed in a thorough way, with as little compromises as possible. The sought perception in the mind of the user should be that the product is genuinely well made and robust in its constructional expression.

Innovative

The product should entice the user with a novel but meaningful expression and function. It should be able to be perceived harmoniously without overloading the users cognitive resources. This connects to the product experience principle of maximum effect for minimum means.

Refined

The product should have a refined visual expression, meaning that it should be very clear in its intended use.

Non-temporary

The product should not express that it is collapsible as it's main expression. The user should be encouraged to use the chair in the same situations she would use a normal, non-collapsible chair. The collapsibility should be, as previously stated, a support function, both in its functionality as well as in the user's perception.

Light

The chair should express lightness as it is a mobile piece of furniture, both in the meaning of it being collapsible and that it should appear easy to move around in the unfolded state.

Steady

While the chair naturally should be functionally steady, it must also express this visually in such a way that the user perceives it as steady.

5.13. Core value Mood board.

After defining the core values, a core value mood board was created. The mood board visualised the previously established core values so that the project member's goals and directions were synchronised. By visualising the core values in a large format, they would be present at all stages of the process. See the board in Figure 40.

The mood board consist of six columns filled with inspirational and expressive images, each describing one core value.

THOROUGH



INNOVATIVE



Figure 40. The Core Value Mood Board

5.14. Inspirational board.

When surveying the furniture market, a lot of inspirational images were collected. These images portrayed different design objects that featured solutions that were interesting in some way. Some of them were of chairs and some of them featured collapsible objects in general or just an interesting shape or material. The images were organised in a grid and printed out in a large format. The process resulted in an inspirational poster or board which was used as inspiration when sketching and brainstorming. See the board in Appendix D.

REFINED



NON-TEMPORARY

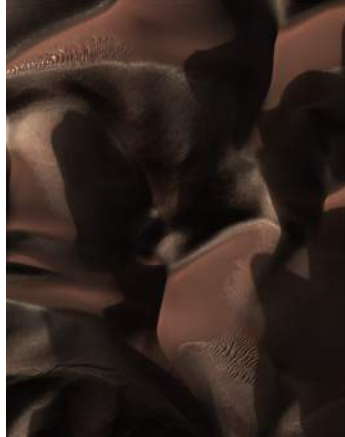

LIGHT

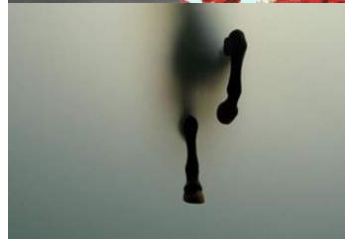
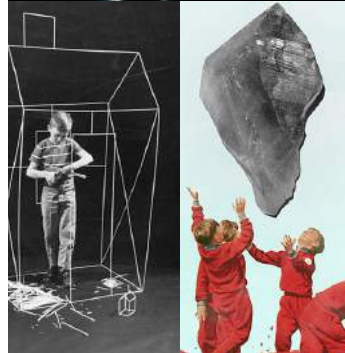

STEADY



6. Creative Ideation

This chapter describes the application and results of the creative ideation process that followed the theoretical analysis. It takes its basis in the gathered data and results in ideas, models and concepts.

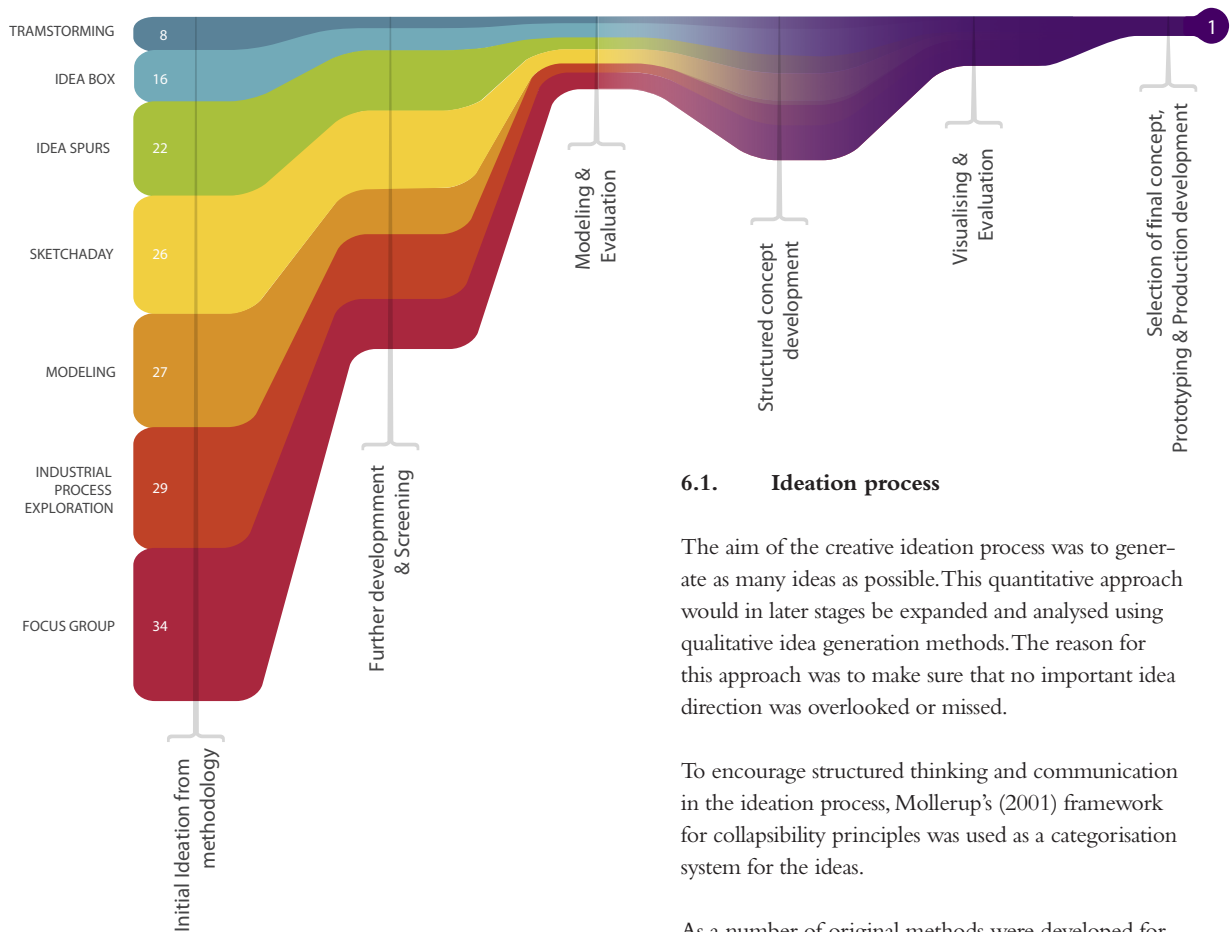

Figure 41. A representation of the ideation process

6.1. Ideation process

The aim of the creative ideation process was to generate as many ideas as possible. This quantitative approach would in later stages be expanded and analysed using qualitative idea generation methods. The reason for this approach was to make sure that no important idea direction was overlooked or missed.

To encourage structured thinking and communication in the ideation process, Mollerup's (2001) framework for collapsibility principles was used as a categorisation system for the ideas.

As a number of original methods were developed for this project, the documentation of the creative work became even more important than usual. The amount of ideas from each initial step and the following evaluations was recorded and is represented in Figure 41.

6.2. Material Process / Form possibility based ideation

An outspoken aim of the ideation process was to make sure that as many form directions as possible were examined. To ensure this it was decided to perform a number of brainstorming sessions based on selected materials and their associated manufacturing possibilities. A template sheet was created and can be seen in Appendix C. Every material was assigned to a sheet and its manufacturing processes were listed in each box to create a good overview and structure. Each process was complemented with important properties and parameters that could be useful in the idea generation. Every process was then the basis of a 5-minute brainstorming / sketching phase.

The main materials and processes covered were:

Metal shaping processes

Cutting (laser, chemical, dye, water), sheet metal forming, metal spinning, vacuum superforming, inflating, kinking, bending tube & wire, rollforming, mesh, hydroforming, moulding, forging, extruding.

Wood shaping processes

Deep 3D-forming, pressed random fibres, chocked wood, gluing, compressed wood (relaxed fibre), bendy-wood™ & flexywood™ (compressed lengthwise), CNC milling, organic woodbending, bending plywood (laminating), woodturning, cutting (laser/water).

Most of these methods to obtain shape are also applicable to other materials such as paper, ceramics, textiles and polymers. As the aim of this method was to investigate shape possibilities, only a small number of additional processes were covered.

The result of this custom method was 29 ideas of which 16 were kept after initial sorting.

6.3. Group ideation

When setting up a focus group, one normally invite users to interact with a problem or product to capture their insights and thoughts and extract thoughts from that. In this focus group, the invited people were instead eight industrial design engineering students who were given tasks to perform using already familiar ideation methods such as sketching and brainstorming. As there was no specific user group for the project chair, the students were chosen as they can act both as chair users and implement their knowledge about ideation techniques.

The invited people were first introduced to the projects core values and were asked to keep them in mind during the creative process. To help the group members, the core value image board was put on a wall for all to see.

The parttakers were asked to bring along an item or image that they thought of as innovative and interesting in its construction, material or function. The items brought were briefly introduced by each person and was then placed in a stack in the middle of the table. The focus group members was paired up two and two, and was asked to grab two items from the table to use for an short ideation session. They were asked to create collapsible furniture based on the interesting features of the products they had chosen. After a few minutes, the ideas was rotated to another pair who was given time to add their thoughts before a new rotation.

This resulted in 34 ideas, of which 10 were sorted out in the first selection.

In the second part of the focus group session, the parttakers were briefed about the origins of the Morphological Idea Spur Sentences. Each focus group member was then given 2-3 spur sentences to use as inspiration for a short sketching session. When the time was up or the group member felt the spur was saturated, new spurs were handed out and a new session began. This was iterated 5-10 times per group member, depending on their speed and preference.

This resulted in 22 ideas of which 14 were brought forth from the first selection.

6.4. Sketch'a'day

There are always discussions of whether it's better to generate ideas with or without previous knowledge of the subject at hand. Some argue that the knowledge helps you to create more realistic ideas fast, while others claim that lateral thinking comes more naturally without any knowledge input. (Zacharakis et. al. 2006)

To make sure that both sides of the argument was covered, it was decided that 15-30 minutes each day during the analysis phase would be spent putting ideas down on paper. The idea behind this was that the whole spectra from no knowledge to good knowledge would be covered. The idea also proved valuable since the actual knowledge gained each day was directly put into practice in an idea sketch.

The method resulted in 42 ideas of which 22 were kept after the initial sorting.

6.5. Tramstorming

In an attempt to find inspiration from other fields and to enable lateral thinking, a brainstorming / sketching session was conducted while riding the tram network in Gothenburg, Sweden. The project members observed buildings, scaffolding, infrastructural constructs and other objects in different parts of the cityscape. These objects were used as an inspirational basis for both functional and aesthetic ideas concerning collapsible chairs design. See Figure 42.

6.6. Modeling ideation

As an important step in further developing the sketches of ideas generated a great deal of models were built. This was a natural step since the chair to be designed was a collapsible chair and not a static object. By building simple mock-ups the basic functionality could be evaluated and developed directly. Building these models also resulted in many new concept ideas. Some of the models can be seen in Appendix F.



Figure 42. A Tramstorming session at full speed

6.7. Idea evaluation

After a comprehensive ideation phase it was time to evaluate the generated ideas. As the main idea generation phase resulted in as many as 162 ideas, an initial broad screening had to be performed. The screening was done with the twelve folding principles as a categorization system, going through each category and discussing / comparing the ideas. After the screening, 80 ideas remained.

The 80 ideas were subjected to careful analysis, the project group took time to work through each idea to see whether it had potential or not. This work was mainly done through small sketching / discussion sessions where the ideas were subjected to scrutiny and further development.

Ideas that featured a collapsing procedure that was hard to imagine were evaluated further to see if they could

be simplified. They were then constructed as small functional models in wood, metal and paper that would illustrate the collapsing techniques. See an example in Figure 43. Many of the ideas that had flaws were revealed at this stage, resulting in them being discarded.

Using this methodology, many new ideas were developed and the non-functioning ones were discarded. Fellow students were also consulted during the screening process, bringing fresh eyes and expertise from other fields. When the evaluation process was complete, the heap of 80 ideas had been reduced to a concentrate of the best ones. 11 ideas remained and these were each realised as a scale model which helped to illustrate the design and the collapsing procedure, all these models can be seen in Appendix F. These concept ideas were pure functional models, no form development had been applied to them, yet they all had distinct forms and shapes as a result of their individually unique collapsing techniques.

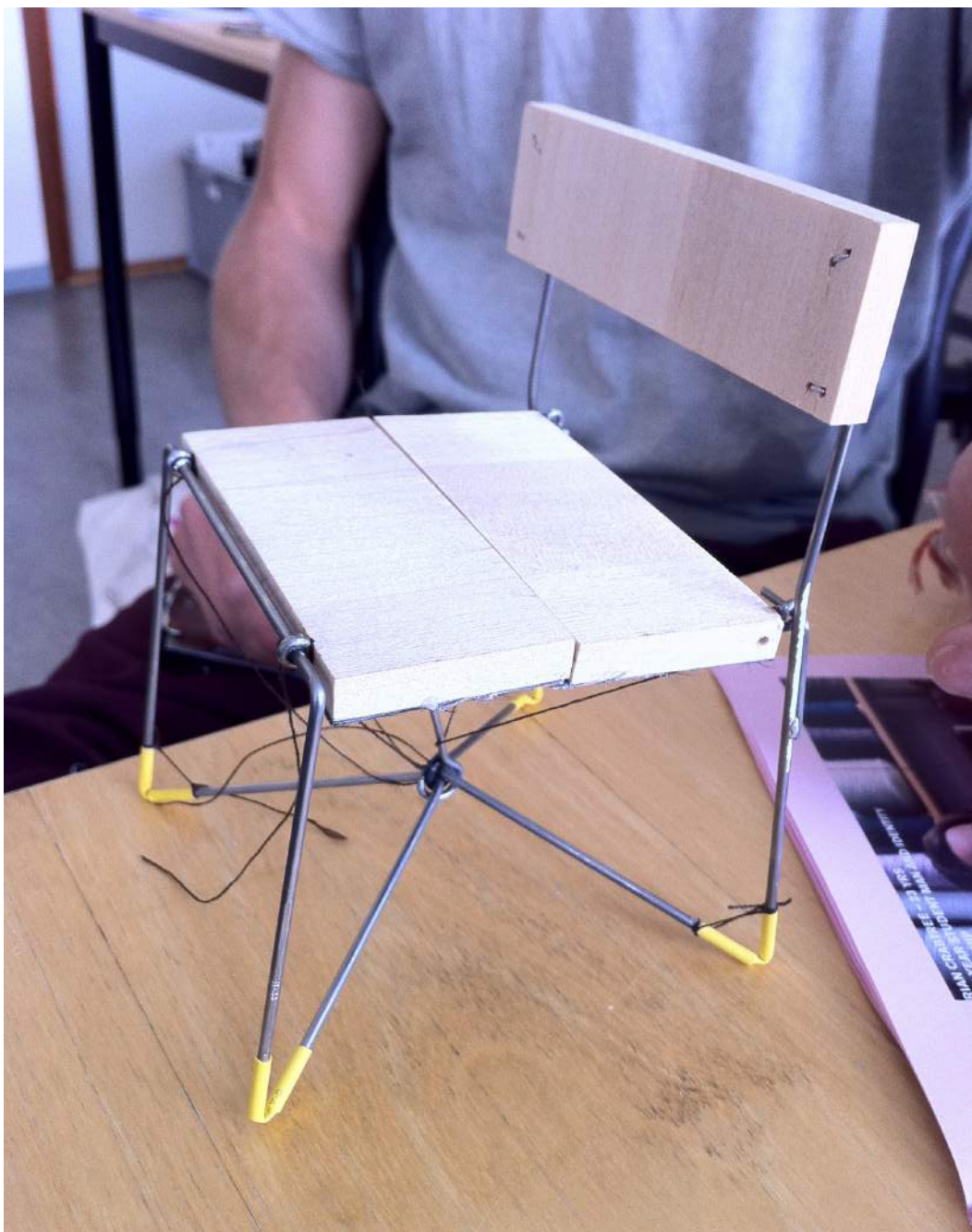

Figure 43.
One of the functional models constructed

6.7.1. The eleven functional concepts

Hinge one

Hinge one is a concept which features a novel functional form language with four diagonal bars that support the frame by a connection point in the center. The concept was called “star” by the project group as it looks as if it’s emitting energy from inside.

It is the first of two concepts featuring a split seat to collapse the chair. The thickness of the seat combined with a hinge interlocks the construction as it is unfolded. One issue with this concept is that since the split line of the seat is turned upwards, there can be a risk of trapping fingers or buttocks there. This is something that most likely could be worked through, for example by covering the seat in a flexible textile or similar. However, this would add to the complexity of the construction though. See Figure 44.

Hinge two

Hinge two is an interesting design as it is made up of thin, flat bars of wood that fold using some kind of flexible rubber-type of joint throughout the design. The seat, which is made from a thin sheet of wood, is rotated around the front legs to fold up against the backrest. See Figure 45.

The concept is interesting to look at but a good solution for the joints would have to be worked out for it

to become viable. Some concerns about how self-explanatory the collapsing procedure was were also raised.

Hinge three

Hinge three is a quite simple but clever concept originated from a simple Lego model. Seen from the top side, the collapsing is realised by four rigid Y-shaped frames that let the two pairs of legs move toward each other to form a quite flat state. One interesting fact, and a potential issue, with this concept is that the movement of the legs forces the seat to reduce in size in one direction while it expands slightly in the other direction. This would require an elaborate seat design. See Figure 46.

Hinge four

Paper folding gave birth to this idea where kinked sheets of metal meet in one joint. The flanges interlock as the chair is unfolded and the interlocking only becomes stronger as the seat is strained. The thin sheets also allow for the chair to be collapsed into a very flat state. See Figure 47.

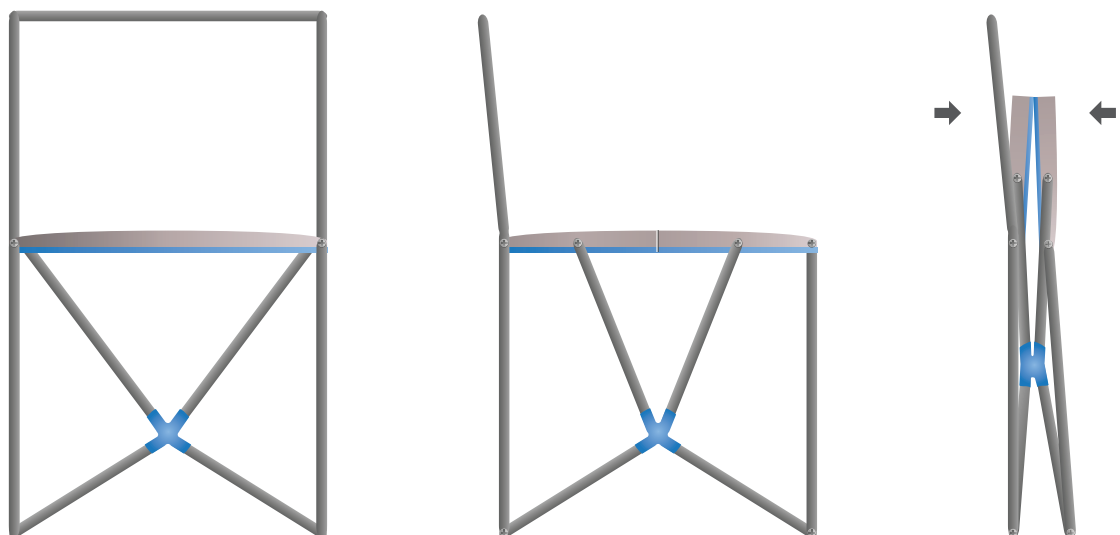

Figure 44. Hinge 1 front view uncollapsed,

Side view uncollapsed,

Side view collapsed.

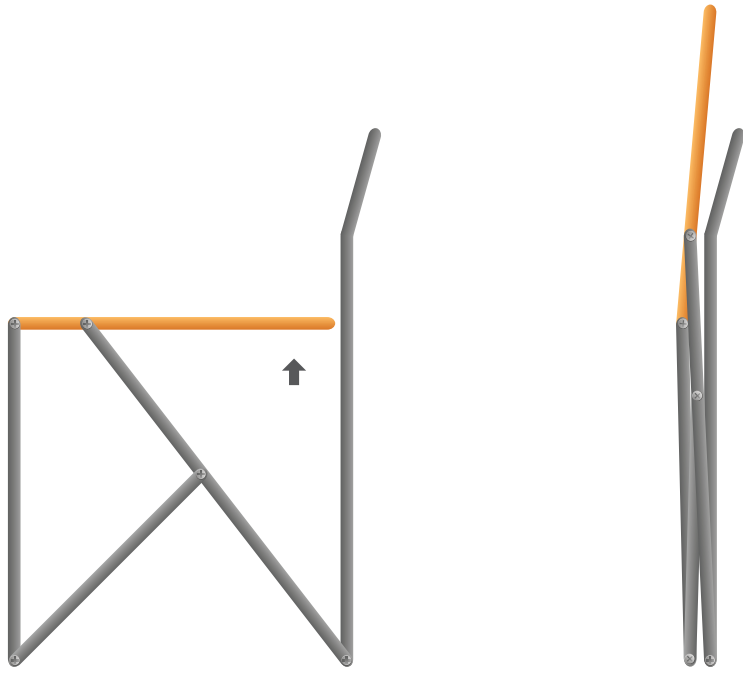

Figure 45. Hinge 2 - Side view uncollapsed,

Side view collapsed.

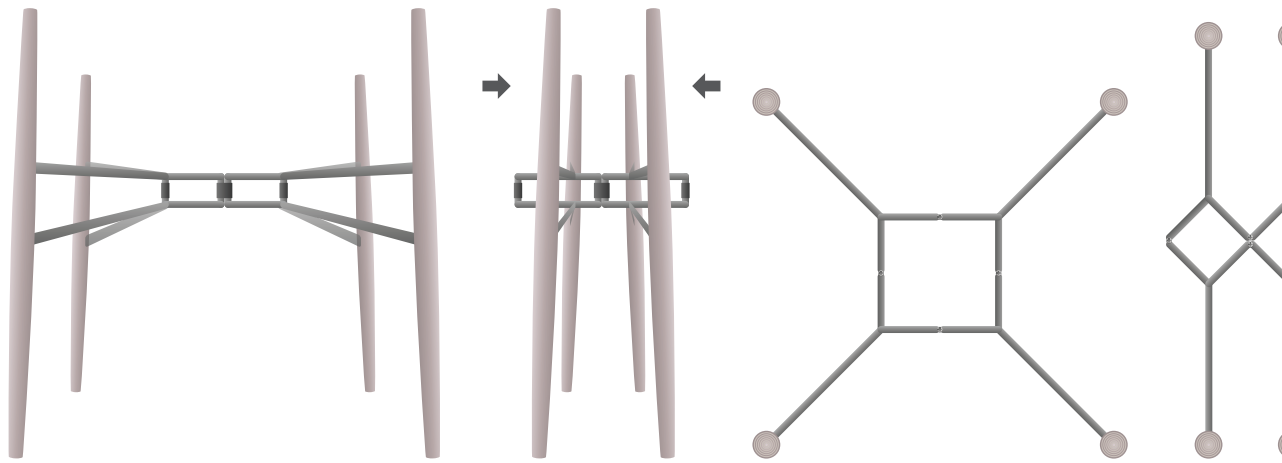

Figure 46. Hinge 3 - Front view uncollapsed,

Front view collapsed

Top view uncollapsed

Top view collapsed

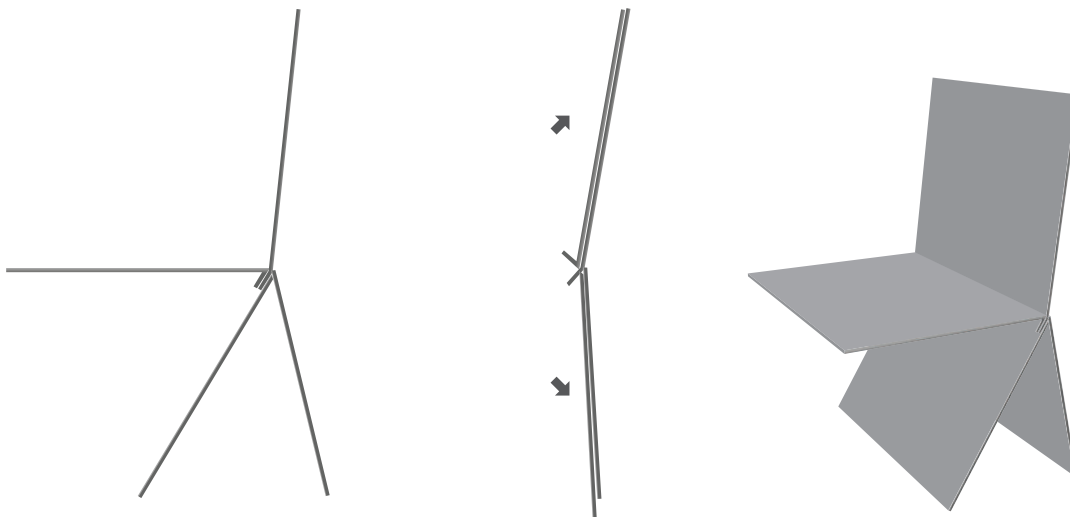

Figure 47. Hinge 4 - Side view uncollapsed,

Side view collapsed

Perspective view uncollapsed.

Hinge five

This idea was first introduced by Johan Lindau as he had an idea about redesigning the classic collapsible beach chair, in Sweden referred to as 'Brasse'. The concept is collapsed by pushing the seat and the backrest towards each other. The concept also features an interesting look with its kinked back leg. A potential issue with this concept might be that the back leg will be hard to collapse flat against the rest of the chair. A lot of development must be put into this process. See Figure 48.

Slide one

A concept similar to "Hinge 1", featuring a split seat but instead of bars connected with a joint, the supporting bars in this concept slide in grooves in the legs. As they hit the bottom the seat is supported. One drawback with this concept was the risk of collapsing as the user tilts the chair, this would need development to create some kind of integrated locking function. See Figure 49.

Slide two

This concept features a very simple but clever mechanical construction. The collapsing relies on a bar connecting the "feet" to the backrest, this bar being somewhat shorter than the feet themselves. This means that when the seat is folded against the backrest, the feet follow and folds up automatically. See Figure 50.

Slide three

The framework of one of the classic Eames chairs was the inspiration for this and the following concept. Connecting the bars to the legs with a joint and making the legs telescopic allows for rather flat collapsed state compared to what the chair expresses. The telescopic legs are self-locking as they are strained with load resulting in a very stable chair with an interesting look. See Figure 51.

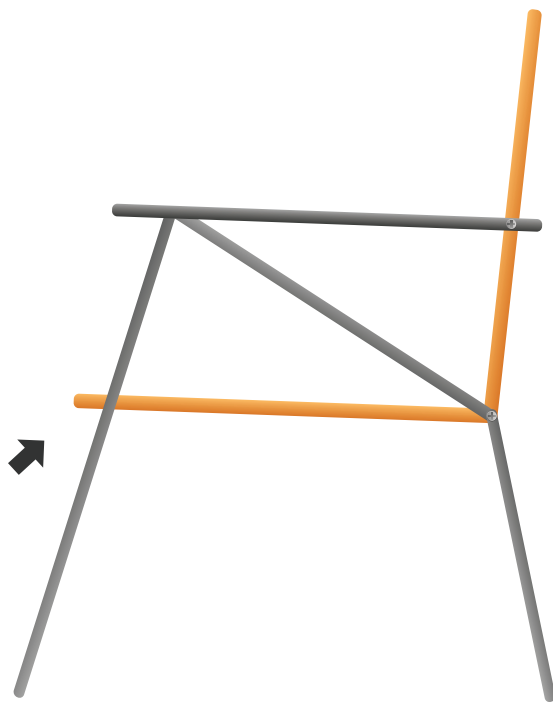

Figure 48. Hinge 5 - Side view uncollapsed,



Side view collapsed.

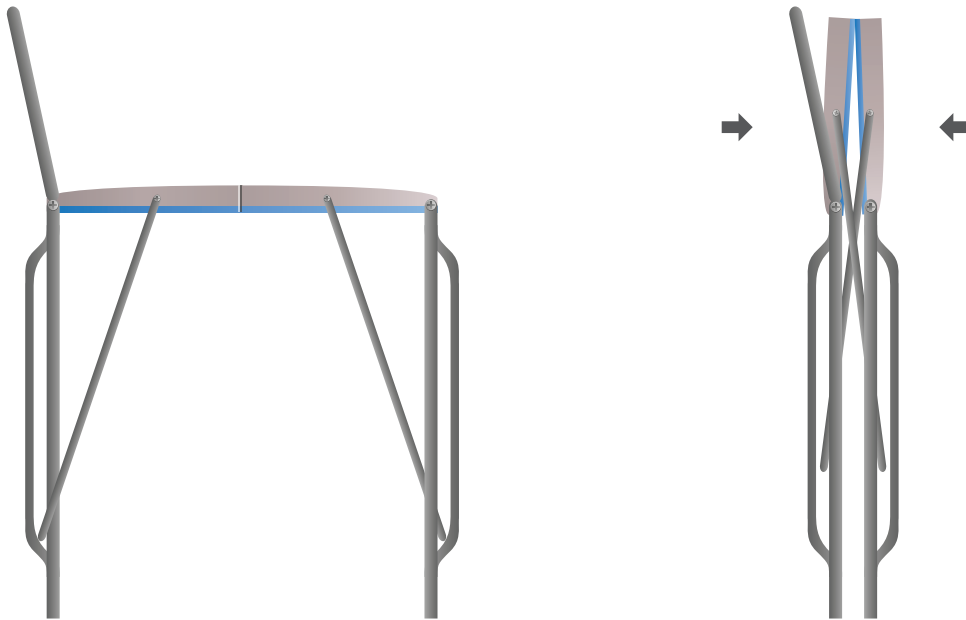
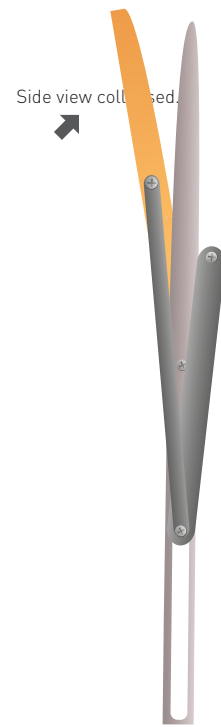

Figure 49. Slide 1 - Side view uncollapsed,



Side view collapsed.



Figure 50. Slide 2 - Side view uncollapsed,

Side view collapsed.

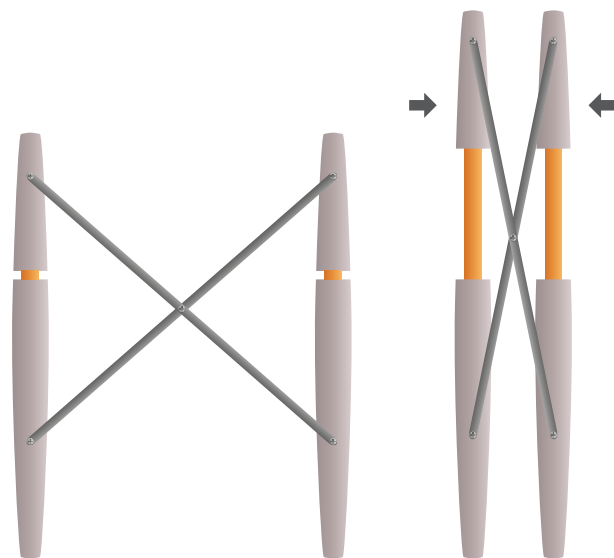
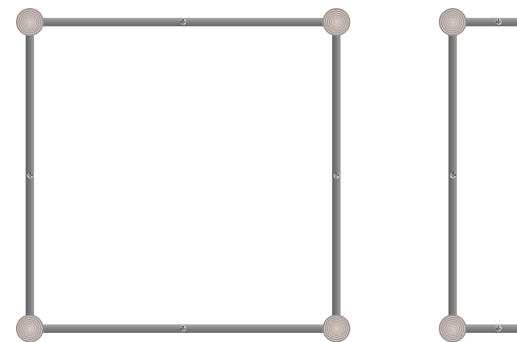

Figure 51. Slide 3 - Side view uncollapsed,

Side view collapsed



Top view uncollapsed,

Top view collapsed

Slide four

This concept is based on the same construction as Slide 3 & 6 with the exception that the four legs are collapsed towards each other. This results in a very compact chair but puts high demands on a very flexible seating solution. See Figure 52.

Slide five

Here the telescopic legs have been replaced by a centered telescopic bar. As with the previous concept, the legs are collapsed towards each other in the middle, but the telescopic arms have been integrated into a single part, resulting in less moving parts. See Figure 53.

Just as with Slide four, this concept sets high demands on a flexible seating solution.

Slide six

In Slide six the seat is collapsed diagonally, putting high demands on how the seat and backrest is constructed. Other than that the construction is very much similar to the concepts above. See Figure 54.

Stress one

Stress one has a flexible sheet put under stress as its main feature adding comfort to the chair. The joint between backrest and seat needs to be well designed to allow collapsing. See Figure 55.

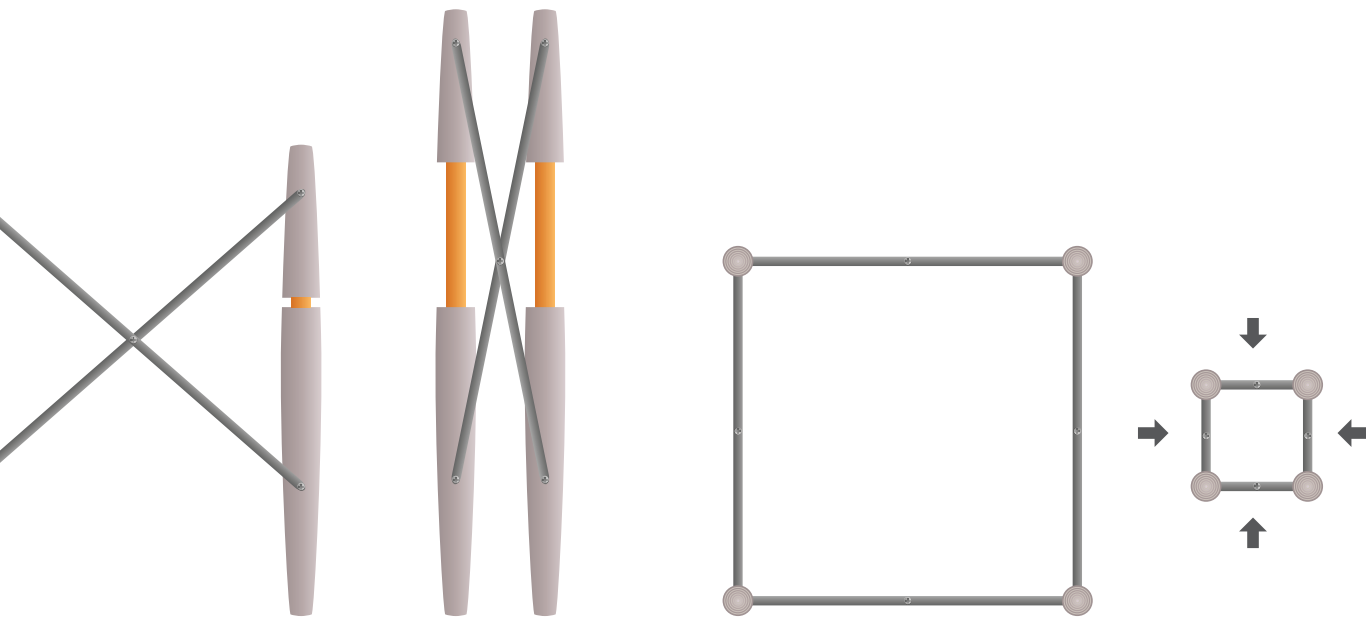

Figure 52. Slide 4 - Side view uncollapsed,

Side view collapsed

Top view uncollapsed,

Top view collapsed

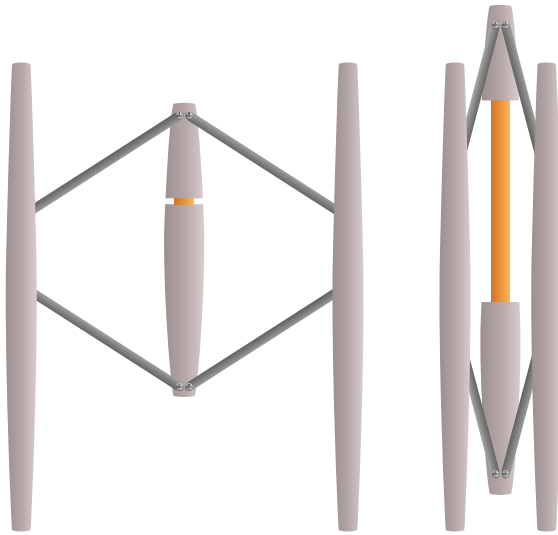
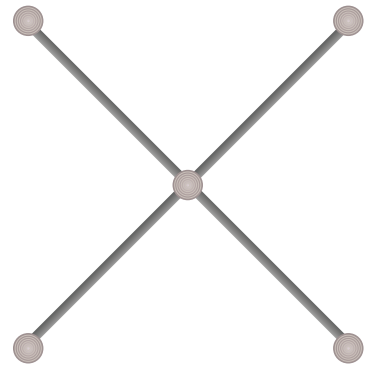

Figure 53. Slide 5 - Side view uncollapsed, Side view collapsed



Top view uncollapsed, Top view collapsed

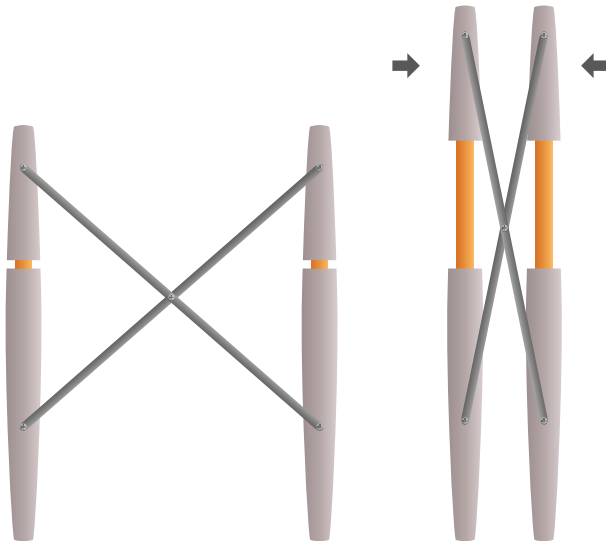
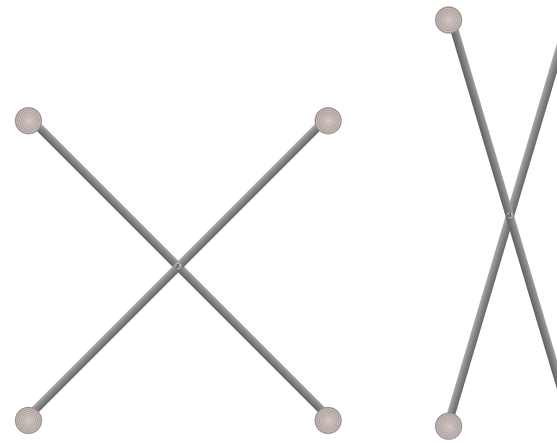

Figure 54. Slide 6 - Side view uncollapsed, Side view collapsed



Top view uncollapsed, Top view collapsed

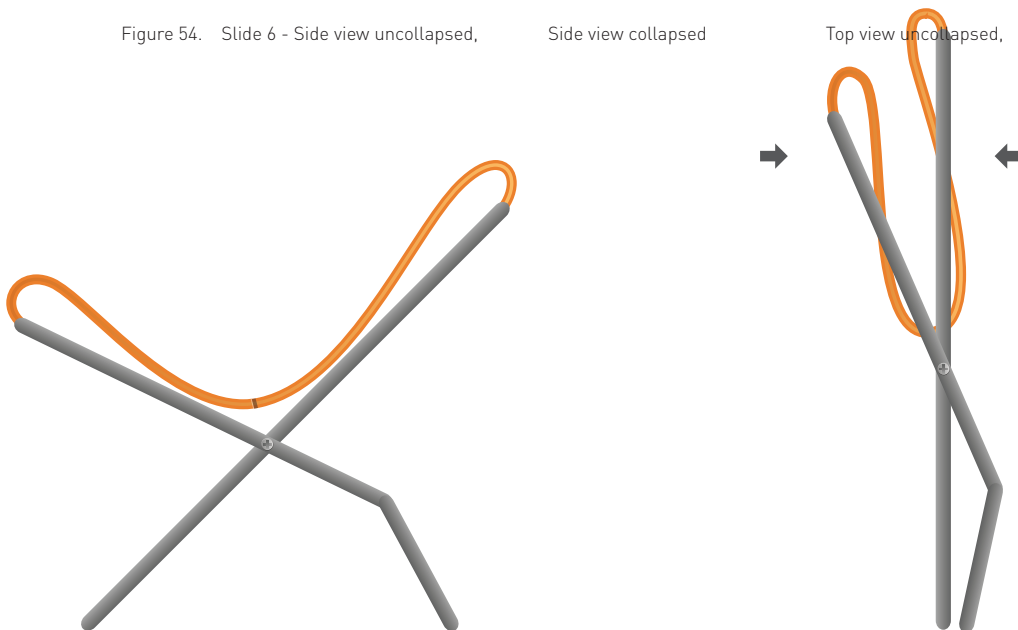

Figure 55. Stress 1 - Side view uncollapsed,

Side view collapsed.

6.8. Evaluation outcome

A couple of days was set aside to spend at Blå Station in Åhus. The concept mock-ups and functional illustrations were presented to Johan Lindau. He liked the ideas behind many of the concepts but stressed several times the need for simple design.

A majority of the concepts featured novel folding techniques but were at the same time quite complex in their construction. More parts results in a higher production cost and greater risk of something breaking. Safety was another big question of several concepts, especially on the chairs with split seat. Concerning concept Slide two, the concept where the feet follows the seat, questions were raised if the user would trust the chair and if it invited the user to sit.

The result of the evaluation with Johan was that three of the concepts were developed further together with a new concept based on sliding principles. The concepts chosen to work further with were Hinge one, two, five (See Figure 57, Figure 58) and the new concept.

To find an as simply constructed collapsible chair as possible the project group chose to try to condense a folding principle as far as possible. The result was a combination of hinging and sliding called concept A. See Figure 59 .

After putting the concepts through a few iterations of development, discussions and analysis, one of the concepts emerged as being the one with the most promise for further development. The reason for this was that the basic idea of the construction was solid and that it was the one that featured the most intuitive collapsibility procedure. The concept chosen to develop further was the high class remake of the classic 'brasse'-chair - Hinge five.

The concept of remaking this classic chair but with the new core values applied, resulting in a high class upright version of the beach chair, was deemed a good design direction by the project group and Johan Lindau. The project tutor and examiner, prof. Ulrike Rahe, was consulted and concurred with the potential of the chosen concept.



Figure 56. Iterative development under way in Blå Station's storage room / thesis office.



Figure 57. Hinge one & Hinge two with the new seat added



Figure 58. Hinge five with redifined proportions & Concept A - a combination of hinging and sliding techniques.

7. Concept Development

This chapter describes the further development of the chosen concept. It introduces three new variants of the previously chosen concept and evaluates them.

7.1. Developing the frame structure

After all the explorative ideation and analysis, the work could now be focused on a single idea. A number of sketches was made to establish the basic proportions of the chair, these sketches were then used to build a CAD-model in Catia V5 where a series of functional tests were conducted to get a better understand of how the collapsing procedure worked and which parameters and measurements were the most important. A number of functional models were also built to further investigate the collapsing procedure and potential design directions. See Figure 59.

These collapsibility experiments resulted in three different main ideas, all relating to the back leg and all having individual characteristics that made them interesting candidates.

Figure 59. Experimental models made from welding wire.

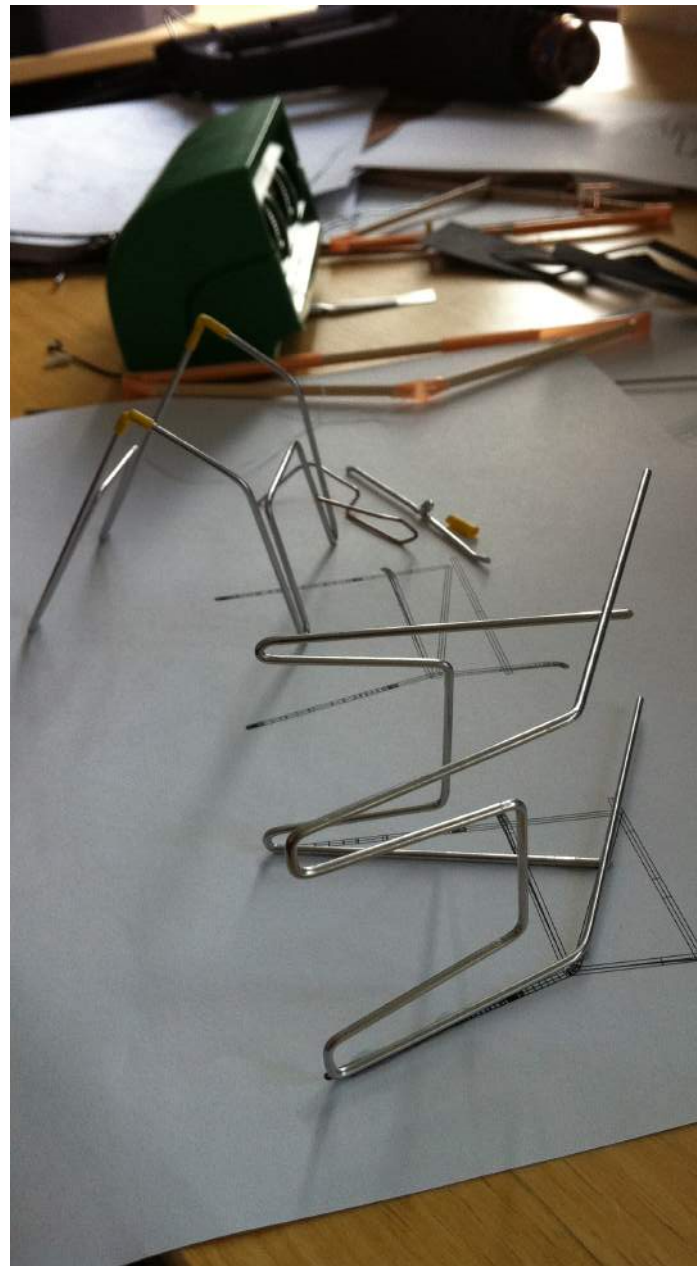

7.1.1. The Unileg

The Unileg frame consists of four main parts, all made from bent steel tubes. The seat frame and backrest frames are manufactured in the same way except an extra bend on the backrest frame which hold the joint that connects the two.

The front leg is bent in a W-shape that creates a seemingly solid gestalt that is supposed to make the chair appear more steady. The back leg is bent in the same way, although it features a kink that allows the connection point to the seat to be placed further back, making the chair appear more stable, both in function and in appearance.

The leg is connected to the seat frame using a 'brasse-joint', a piece of steel plate, which lengthens the seat frame when collapsing the chair, resulting in a flat collapse state.

The chair is stabilised by a small locking detail that hinders the back leg from sliding backwards. This solution is used in standard Brasse beach chairs but is not made with very sleek tolerances.

One issue with the design of the kinked back leg was that it took up a lot of space when collapsed into its

flat state. Experiments of how this could be corrected were made and models were built to see if this protruding leg could be used to help the chair balance in the collapsed state. This proved to be difficult, as both the angle and height of the leg had to be altered. A structured form development approach was also used to test all different possible angles of the kink in the frame to find the optimal one.

Four key factors was identified to minimize the thickness of the chair in the collapsed state:

- Minimize the distance between the front- and back leg's attachment points to the seat
- If the front and back legs meet in one point of the armrest, maximize the height of the armrest
- If the legs don't meet in one point, maximize the distance between the attachment points of the two
- And finally, maximize the angle of the rear leg resulting in an as small kink as possible

The concept was refined using these criteria resulting in a chair which did not collapse flat, but could be stacked to compensate for this. See Figure 60.



Figure 60. The Unileg concept

7.1.2. The Split

The Split concept built on the idea to split the rear leg and thereby replace the brasse-joint with the lower part of the leg. The lower leg would then be able to rotate around the connection points between the legs, resulting in a collapsed chair with a much lower height. See Figure 61.

To make the chair more comfortable, the seat and backrest frames features a small kink at the front and top. This enables the user to sit in the chair without feeling the frame structure through the backrest and allows for better blood flow in the thighs.

To test the collapsing procedure, a number of models were constructed using Lego Technic, a mock-up tool often used by the project group when building mechanical models.

These models showed that the bar connecting the back leg to the armrest would have to be kinked to be able to connect to the back leg, otherwise the angle of the leg would become much too big.

The solution to this was to make the back leg bend up again to connect with the bar at the top. This theory was proven by building an aluminium model in scale 1:5.

The solution with the new back leg was discussed as it clearly solved two problems:

Firstly, it removed the brasse-joint, saving in on costs and assembly time. Secondly, it replaced the small locking device, the detail that stops the leg from sliding backwards, by integrating the functionality into the back leg itself. Creating a stable construction.

At the same time as it solved these problems, the construction of the back leg uses more material, resulting in more weight and longer manufacturing times.



Figure 61. The Split concept

7.1.3. The Simplex

The Simplex concept is just as it sounds, a simplification of the basic chair idea. The concept is based on the fact that the front and back legs are made as identical parts, without kinks or extra bends. This makes the manufacturing of the chair a great deal more economical.

As the legs are completely straight, the collapsed thickness of the chair can be reduced, resulting in that a larger amount of chairs can be packed together in a stand or trolley.

The Simplex concept uses a 'brasse'-joint in the same way as the Unileg. This joint is somewhat longer in the Simplex concept.

The concept locks the back leg from sliding using the same solution as the Unileg concept, but the locking details is placed further to the front, making the back side of the seat look like it 'hangs' backwards. This fact was the main argument against the Simplex concept, it was argued that the 'hanging' of the seat made the chair look less stable and trustworthy. See the concept in Figure 62.



Figure 62. The Unileg concept

7.2. Concept Evaluation

To evaluate the concepts in an objective way and to find the weaknesses of each concept a Pugh-matrix. (See Appendix G) was set up to compare the concepts. Each concept was rated based on a number of factors inspired by the core values and the set up requirements of the project; simple (cheap), stable expression, safety, flat folding, stacking and simple collapsing technique.

The concept that scored the highest turned out to be 'Unileg' (12 points) closely followed by 'Simplex' (9 points). The 'Split' concept scored the lowest, -9 points.

The factors causing the 'Simplex' to score lower than "Unileg" had to do with stable expression and safety.

After highlighting the main problems of each concept using the Pugh-matrix the concept development of the "Simplex" was given one more iteration. Once again a structured form development approach was used to gradually increase the angle of the front leg until the position of the seat felt more balanced and trustworthy.

The three concepts were then visualized and presented to Johan Lindau. A discussion followed, resulting in the choice of the final concept, The 'Simplex'. Johan appreciated the flat packing the collapsed chair resulted in and reinforced the project group's opinion of the concepts stringent form language. He also thought that this concept would be the easiest and most economical to manufacture.

To finalize the frame proportions, a new model was built in scale 1:5, see Figure 63. This one was constructed using aluminium wire and was used to establish in the final proportions and measurements that would be used to develop a prototype..



Figure 63. The scale model built to define the final measurements and proportions of the chair.

8. Refinement & Prototyping

This chapter describes the further development and refinement of the 'Simplex' concept. It also dives into the construction and design of a full size prototype.

As the 'Simplex' concept had been chosen, the collapsibility was further developed to achieve an as flat collapsed state as possible. Calculating how the chair is to collapse proved to be a real challenge. Several models, both digital, using CATIA V5, and two dimensional physical models were used to achieve an as good collapsing procedure as possible. See Figure 64.

One big problem as the two-dimensional models where to be transformed into three-dimensional was that the seat collided with the strut of the rear legs. Another problem was that the seat wouldn't lie parallel to the legs when folded. To solve the first of the two problems, attempts were made to move the strut of the rear leg down (using a structured development approach) to prevent it from colliding but this solution was not aesthetically satisfying. See Figure 66. Instead, the axis

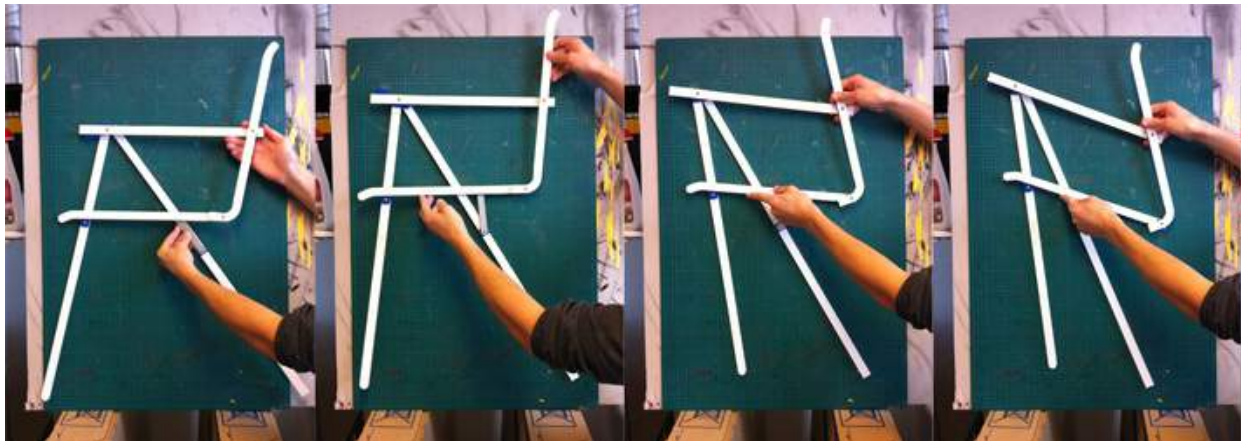

Figure 64. Physical 2D model investigating the mathematics behind the collapsing procedure.

around which the seat revolves was offset. A fear was that this would complicate the construction but as can be seen by the red axle in Figure 65, the only difference from the old solution is a 90 degrees kink on the axle and that the axle enters the pipe of the seat from below instead of from the side.

To enable parallel folding, the seat had to be adapted by discarding the idea of wraparound textile and instead choose a seat which only covered the top of the frame. The simplest solution to this is to use a hard material that is easily fastened in the frame but an alternative is to further develop the fastening of a textile that only covers the top. See the blue line in Figure 65.

The last sketch shows the stop that prevents the chair from collapsing. The classic Brasse-chair has a large and visually disturbing stop in form of a cylinder but for the Simplex concept a more visually pleasing solution in form of a bent flat steel plate was developed.

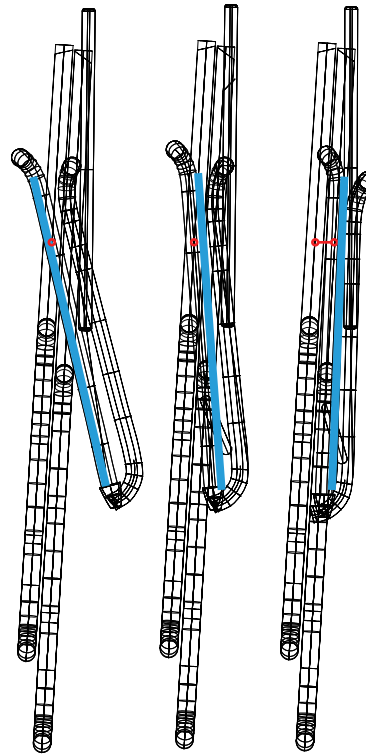

Figure 65. The result of the axle modification.

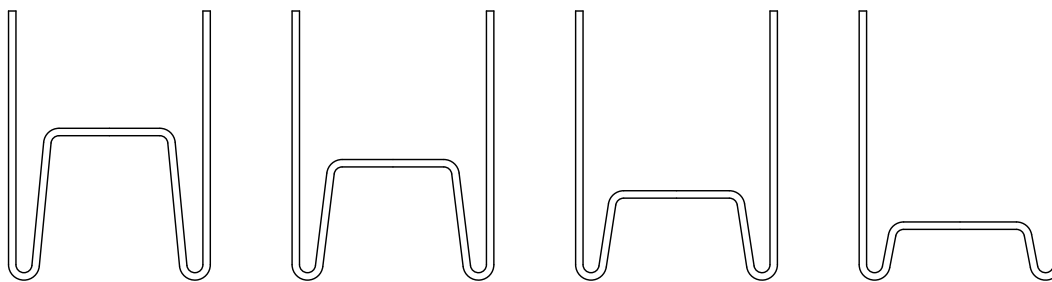
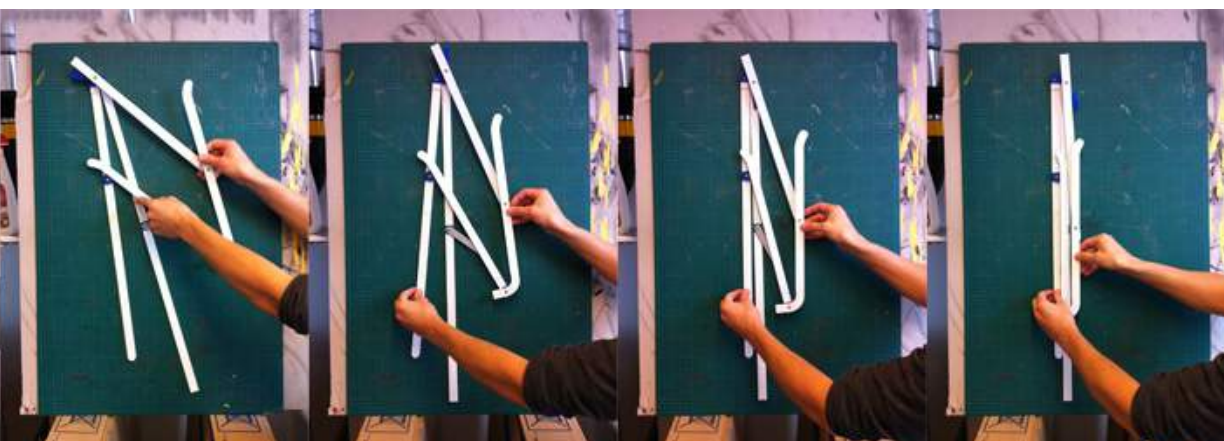

Figure 66. Attempts at lowering the strut of the leg. The lower the strut, the weaker the gestalt.



8.1. Manufacturing of Applåds frame

Blå Station's subcontractor Bending Group was contracted to manufacture the steel frame tubes. A study visit was conducted to better understand the possibilities of their manufacturing techniques and discussions with Magnus Weinbach, head of marketing at Bending Group, resulted in many useful insights. The one affecting the development of Applåd the most was the minimum bending radii of the pipes. Most critical was the radii forming the end of the legs. These very much affected the expression of the legs, if the radii were too big, the distance between the gestalt of the legs became too small resulting in a clumsy expression.

After an experimental form development phase with a minimum bending radii of 30 mm, a leg design fulfilling the semantic requirements was achieved. See Figure 67, Figure 68 and the final bending radius in Figure 69.

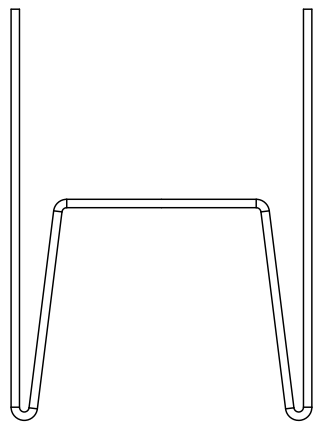

Figure 67. Bending radius of 20mm, resulting in a very pointy and unsteady expression

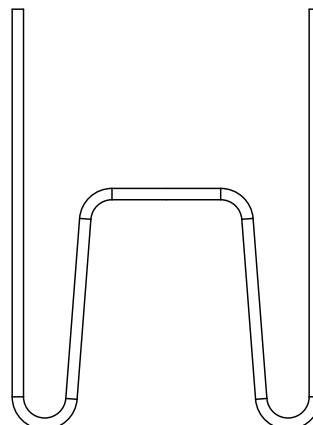

Figure 68. Bending radius of 40mm, resulting in a clumsy expression.

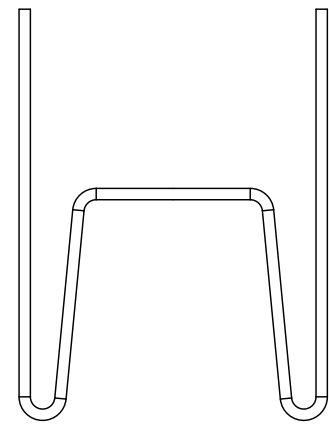

Figure 69. Final bending radius of 30mm, resulting in a steady and balanced expression.

The next problem was the depth of the legs. When bending a tube, the wish is to bend one bend after the other without needing to remount the pipe. However, as the legs of Applåd are so deep compared to the small bending radius, this results in the tube colliding with the bending machine. To avoid this the two upper radii are bent first followed by the ones forming the feet of the legs. This is not optimal from a manufacturing point of view and should be investigated further.

To facilitate production, the front- and back legs are identically bent. The only feature differing them is the length of the outer pipes resulting in a greater inclination of the longer back legs. See Figure 70 & Figure 71 for the final bending blueprints of the legs.

The symmetric bending also applies to the kink of the seat and back. By constructing the parts this way production can be facilitated and costs kept low.

As Applåds frame is meant to be produced in chrome plated steel it was desirable to apply the same manufacturing methods to the prototype. But as time was scarce, Jan Bragée at Chalmers prototype lab suggested that the frame could be manufactured using stainless steel. Doing so could achieve the same look as chromed plating without needing to send the frame away for chrome plating. Bending group was asked to investigate the possibility of this, but as they rarely work with stainless

steel they were unwilling to take on the task. Instead another subcontractor of Blå Station was contacted but they could not fulfill the requirements of the 30 mm bending radii. Therefore, despite the extra time this consumes, Bending Group was assigned to manufacture the frame in black steel. The bent pipes were then sent to the project group for refinement at Chalmers prototype laboratory before being sent away to be chrome plated.

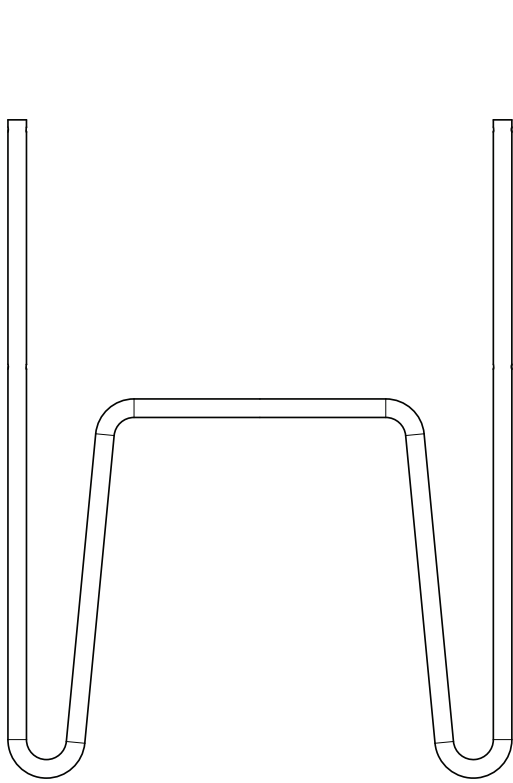

Figure 70. The final bending blueprint of the front leg

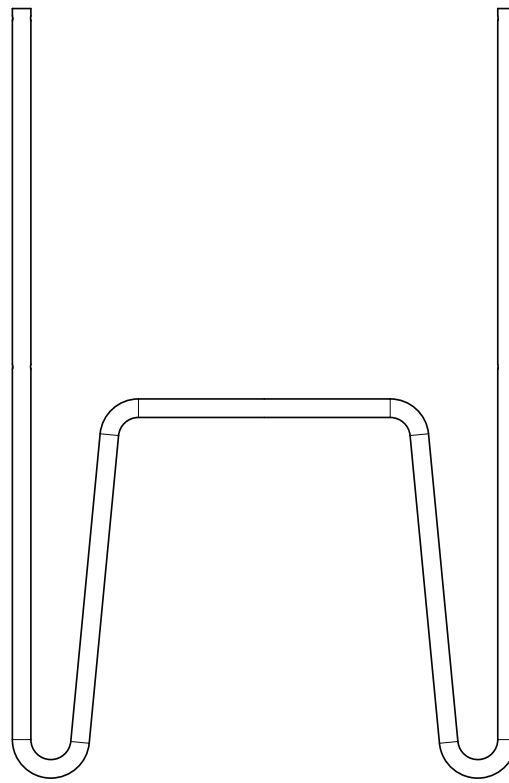

Figure 71. The final bending blueprint of the back leg, identical to the front leg except for an additional 100 mm in height.

The manufacturing of the legs proceeded without any problems but as it came to the kink on the seat and backrest Bending Group had problems bending as had specified. See the problem highlighted in red in Figure 72. The bend specified was three-dimensional and the project group had gotten the impression that this would be possible to manufacture through first bending the r30 bend, then hydraulically press the kink. Although drawings of the frame had been sent to confirm that the construction was producible a misunderstanding resulted in a kink that did not fit the felt already manufactured. The problem was that the metal bent once (in the r30 kink) did not want to bend again in another direction. This combined with a relatively thin wall thickness compared to diameter of the pipe resulted in a crude kink that buckled on the backside.

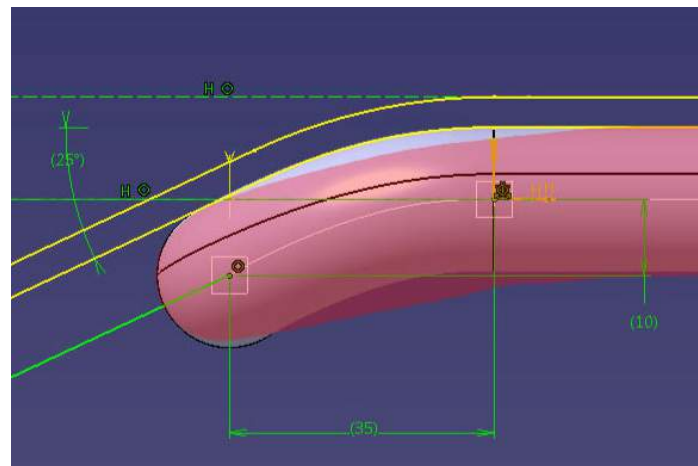

Figure 72. The manufacturing problem with the kink highlighted red over the original blueprint.

The alternatives to kinking as specified were the following:

- (1) Place the kink well before the r30 bend resulting in a very long lip of approximately 60mm (in contrast to the specified 35)
- (2) Minimize the lip to 45mm but reduce the kink angle in the process
- (3) Skip the kink and minimize the lip to about 10mm

Johan Lindau was consulted to give some input. He was of the opinion that a lip for the backrest is necessary and invites the user to sit. This could be made either as alternative one or two. For the seat, his opinion was that a too big kink would look dominant, either alternative two or three was suggested.⁹

The kink is important for the expression of Applåd as the backrest becomes very square if it is left out. It is also important from an ergonomic point of view as the horizontal pipe of the backrest is not as flexible as the felt, resulting in an uncomfortable backrest. Also for the seat the kink is of ergonomic value as this gives a smooth transition that does not congest the legs blood flow.

As described above, it is desired to kink the backrest and seat identically to facilitate production. The project group agreed with Johan Lindau and chose to kink the seat and backrest as alternative two. One potential issue was if the cloth would wrinkle as the felt was forced to fit the pipes. Tests with the samples made at NÅ Formtextil showed good flexibility and if the felt was properly fastened this should not be a problem.

8.2. The joints

Much consideration was given to the revolving axes that enables folding of Applåd. The construction focused on as simple solutions as possible, yet enabling for disassembly if a part need to be replaced.

The joint connecting the seat to the backrest is a real challenge as the two tubes need to meet each other creating the expression of a single tube. There are several more or less advanced joints to solve this problem but the best joint combining simple manufacturing with discrete visual appearance is the classic half in half joint.

There are various options of how to construct this joint. One is to manufacture solid plugs which are inserted and fastened in the tubes. Another is to fill the tubes with plugs, thereafter mill the tube-ends to the sought form. This creates a more uniform look than the first alternative due to the lack of a visible joint between tube and plug.

A third alternative, that is suitable for simple manufacturing but requires some investment in tools is to compress the pipe as in Figure 73. This requires no additional material. The only concern is if the pipe will sustain its round shape opposite the compressed side. A version of this joints construction was suggested by Magnus Weinbach at Bending group. He suggested that the two pipes could be compressed while sustaining the roundness and claimed that this is a common way of constructing a joint between to pipes. If this simple technique could be modified as suggested by the project group this could prove to be an simple and cheap way of constructing the joint.

For the prototype, a more time consuming but simpler construction will be used as the tools for compressing the tube had to be manufactured before testing could begin.

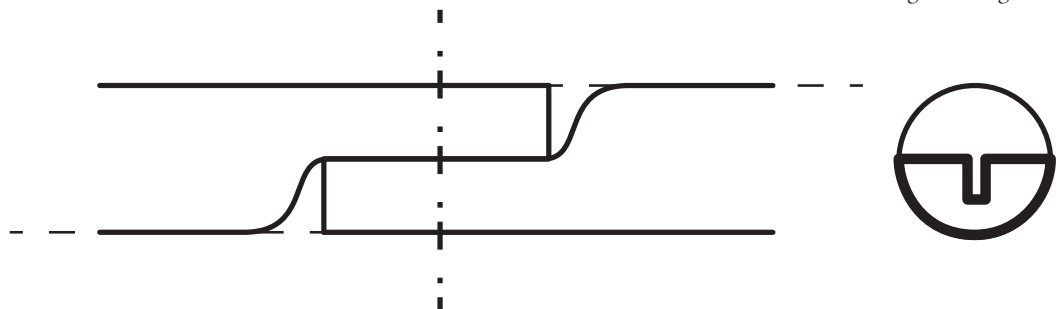

Figure 73. Compressing the pipes as illustrated form a half in half joint with maintained outer radius of the tubes.

⁹ Johan Lindau (CEO Blå Station) Interviewed 22 september 2011

8.3. The locking detail

When the chair is unfolded, the back leg pivots backwards and must be stopped when it reaches its correct position. In the traditional Brasse chair, the back leg is stopped by a small pipe-like detail which sticks out behind the connection point of the leg. This is an effective and simple solution but it is also a detail which disturbs the overall visual expression of the chair. A solution like this would not fit the core values of the Applåd chair. Because of this a number of ideas for more refined solutions were developed.

Since the part to be locked is tube-shaped, it was decided some kind of plate or wire hook would best suit the function. The material finish should be the same as the tubing to blend further into the visual expression of the design.

Since the chair is collapsible, the hook would have to be able to fit the back legs in both states. Thus the detail would have to allow an angle change of the leg of about 45 degrees.

The wire hook would be a good functional solution since its round shape could meet the back leg tube in the two different angles demanded by the folded and unfolded state without having to rotate. See Figure 74. Not having to rotate means that the axle going into the seat frame could be welded into position as opposed to screwing, this eliminates the risk of the hook turning the wrong way due to incorrect handling.

The problem was analysed from a design for assembly (DFA) point of view to see if any parts could be inte-

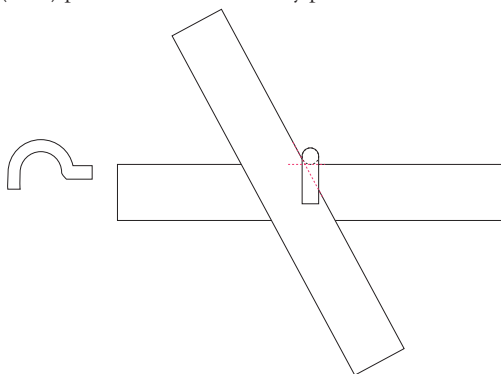

Figure 74. The wire hook fits the tubes in both rotations.

grated into each other. This gave the idea to integrate the hook into the side of the sheet metal hinge that connects the seat and back leg tubes. This idea turned out not to work since it collided with the lower part of the back leg when the chair was folded.

A third idea was to have a loose hook made from sheet metal. This hook would be able to rotate, but would be fastened more tightly so that the movement of the brassehinge would not affect it.

The chosen solution was to weld together a sheet metal hook with the axle the brasse hinge rotates around. By doing this, the hook could be hindered from rotating by using a tight bolt construction. This would also enable the hook to have the exact measurement of the back leg, giving a more subtle expression and a closer fit. See the mechanism in Figure 75.



Figure 75. The final locking detail

8.4. Developing the seat and armrest

The first thing to consider when developing the seat is that it has to stay as close to the top surface of the seat tubing as possible, this to avoid a collision with the back legs. This basically means that the seat should stay on top of the seating frame, not sticking down at all. See Figure 76.

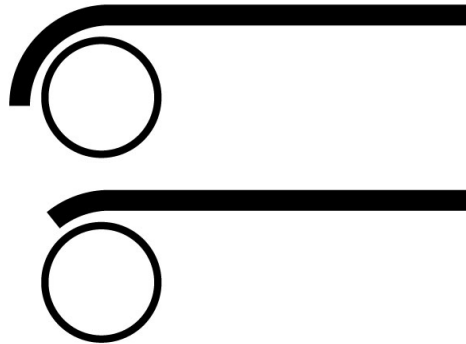

Figure 76. Alternative seat fittings that all stay above the tubing.

To ensure a flat collapsed state, the backrest can be constructed to stack with the seat. This will save some valuable space which would otherwise make the collapsed chair thicker.

When it comes to designing a sturdy and durable seat with fitting visual expression, a number of materials can be viable candidates. Sheet metal is one of them, it can be either bent or pressed in combination with some cutting or milling. Another one, which is a material commonly used by Blå Station, is felt. The felt is made from needle punched polyester fibres which are heated and compressed to acquire the wanted shape and sturdiness. ABS plastic is also an alternative, suitable for large production quantities and resistant enough for outdoor usage.

The seating is designed to follow the contours of the tube frame without covering it too much. By cutting the seat higher along the front of the seat and the top of the back more of the frame is shown and the expression of the chair becomes more cohesive.

Parallel to the development of the seat the design of the armrests took place. A number of parameters to consider were listed. The foremost ones being the space available to ensure an uncompromised collapsing of the chair and the attachment points where the armrest is connected to the rest of the structure.

The frontmost end of the armrest is connected to the legs by a short piece of steel plate referred to as a "Brasse joint". This design allows for a two step adjustment of the backrest angle. This attachment point should also allow for the small steel plate to be resting in an downward angle from the horizontal plane to ensure that the chair is locked in the primary backrest angle.

In the backmost end the armrest should be connected by some kind of screw or bolt inserted straight into the backrest frame.

The distance between these two points is essential to ensure a flat collapse of the chair. Simulations in CATIA V5 were made to find the correct measurements, the tool used was the Digital Mockup Kinematics work bench.

The space available for the armrest is controlled by a number of other parts. In the folded position the armrest must not collide with the backrest both in the X- and Y-direction. It must also provide sufficient space in the Z-direction or be thin enough not to collide with the back leg in the folded position.

This available space was condensed into a 3D-model which was then used in the ideation process as a design boundary. See Figure 77.



Figure 77. The space available for the armrest.

When starting the ideation process for the armrest, a number of factors were considered. The design must be simple enough to accommodate cost-effective production, this somewhat limiting the choices in materials and manufacturing processes.

A number of starting points based on material types and processes were listed, these can be reviewed in Appendix E.

Form development based on selected materials and manufacturing techniques using Rhinoceros 4 was conducted resulting in over 20 unique concepts. From these, a handful of concepts were selected and visualized with rendered images from Keyshot 2.

Two important features were set when evaluating the armrest concepts, low cost and harmony with the design of frame and seat. The number of concepts was further reduced to two with the help of the Chalmers tutor, Ulrike Rahe.

The final armrest concept chosen was a open P-profile of pressed felt. By manufacturing the armrest of one single material, the same as the one used in the seat, this concept fulfilled the demands of low cost and harmony with the chair as a whole. See Figure 78.

Blå Station has been an important actor in developing felt for use in the furniture industry. A number of their chairs uses felt laminated with woven textile and they continue to explore the possibilities of felt, lately through the chair “Spook”.

Felt was chosen as an alternative for indoor usage. Laminated with textile the felt gives a warm and solid expression that communicates well with the core values of the chair. Also, the haptic experience of felt is warm and welcoming. All of these properties contribute to the non-temporary expression the chair aims for.



Figure 78. The felt seat before production adaptation.

8.5. Manufacturing seat and armrest

The felt detail is manufactured through heating and pressing needle punched polyester fibres. The pressing tool consists of one positive- and one negative mould that can be made of MDF or Ureol, for smaller/less challenging series, or more wear resistant materials i.e. aluminium for larger series.

To minimize tooling investment cost, the backrest and the seat are pressed using the same tool. In this tool the mould for the armrest can be integrated so that one part of the seating and one armrest is pressed in the same manufacturing step. Edges are then cut out, either directly in the mould (taking advantage of the time the detail needs to cool inside the tool), or using a template after the detail is removed from the tool.

For the prototype, a pressing tool could be manufactured by hand or by milling. The largest drawback of making the tool by hand is the high time consumption and inaccuracy that this will result in. With the kind help of SSPA (Statens Skeppsprovingsanstalt) the tool was milled using their CNC milling machine, normally used to mill scaled ship hulls (up to 16 m long and 3 meter wide). See the milling of the tool in Figure 79.

Based on the CAD model of the chair's frame and seating a model of the pressing tool was built. The first model was developed in close collaboration with Niklas at NÅ formtextil but proved to be too complex for an efficient milling process. It was then simplified by removing the inner radius on the male tool. The armrest originally had an asymmetric design with one 8mm and one 13,5mm round (See Figure 78 on page 77), visually communicating with the radii of the seat, but since the mill head used to mill the large surfaces of the tool is 10mm diameter and a shift of mill head would take too much time (*the milling cost was two nice bakery cakes*) the visual difference between 10 and 13,5 was too small. Therefore it was decided to use 10mm rounds for the prototype of the armrest.

As the tool had been milled and polished the car was loaded and sail was set for Halmstad. Niklas welcomed the project group and showed how to mount the tool in a hydraulic press. An initial pressing test was done with pure felt, without lamination with textile.

The group wanted to test if it was possible to do text embossments in the felt and had therefore lasercut the surnames 'Lamm / Hoogendijk' in 1 mm polystyren and mounted them on a paper which could be placed in the pressing tool. Niklas was fond of the idea and said that several of the producers he worked with had wanted to try the method but no one so far had come about actually doing it. It was therefore with great expectation the first felt detail was lifted. See Figure 80. The result exceeded the expectations and it was decided to place the embossments on the underside of the seat, making it visible only as the chair is collapsed.

Prototypes were manufactured in antracit coloured felt laminated with four colours of textile. These colours were chosen from Blå Station's colour range to fit their product portfolio.



Figure 79. Milling of the felt tooling.



Figure 80. The embossing experiment



Figure 81. The three components of the felt pressing process. Bottom up: Polyester felt. Polyester glue sheet and Furniture textile



Figure 82. Armrests and seats produced in different colours picked from Blå Station's colour range.

9. The final design

This chapter describes and summarises the Applåd chair in terms of features, materials, manufacturing, visual expression and ergonomics.

It also includes a sustainability analysis which suggest alternative materials and solutions.

9.1. The Applåd Collapsible Chair

The Applåd chair is a collapsible chair designed to fit in the middle of the spectrum between a temporary collapsible chair and a permanent normal chair.

Collapsible chairs in general have a bad reputation of being cheap, of low quality and uncomfortable. They often look and feel wobbly and unsteady and also often features visible constructual joints that make them look unrefined.

9.1.1. The frame and visual expression

The Applåd chair has been designed to exude steadiness at the same time as it expresses lightness. This has been achieved using a frame design that creates 'ghost legs', legs that are not actually present but are perceived as a gestalt through the inclusion and closure factors presented by Monö (1997). The user can still see through the relatively thin legs which contributes to the light expression of the chair. (See Figure 83)

The main shape of the chair is strongly characterised by the prominent legs and the seat/back frame that hangs out towards the rear, creating a stringent look with a bold form language. The project group believes that the strong form language together with the steady gestalt expression makes the chair be perceived as less temporary than the average collapsible chair.

The seat, armrest and backrest form a visual unit through material, colour and form design. Form elements in the front side of the seat are repeated in the shape of the armrest, further connecting them visually. (See Figure 84)

Figure 83. The 'ghost leg' gestalt.



Figure 84. The Applåd chair final concept / prototype





Figure 85. All bends are designed using the same radius.

The same use of repeated explicit visual design cues can be seen in the frame structure where all bends use the same 30mm radius. This creates a cohesive visual expression that gives the chair a refined look. (See Figure 85)

By hiding the mechanism controlling the backrest angle inside the armrest instead of placing it visible like in beach chairs, the chair's expression of thoroughness is reinforced. (See Figure 86)

The perception of thoroughness is further amplified by the fact that no visible screws, bolts or welding points are seen from the outside of the frame. All of these connectors have been placed on the inside of the frame to minimise the amount of visual clutter on the outside.

9.1.2. The seat and backrest

The seat and backrest are each made up from two parts, a chromed steel tube structure and a form pressed polyester felt part. The two have been designed to fit

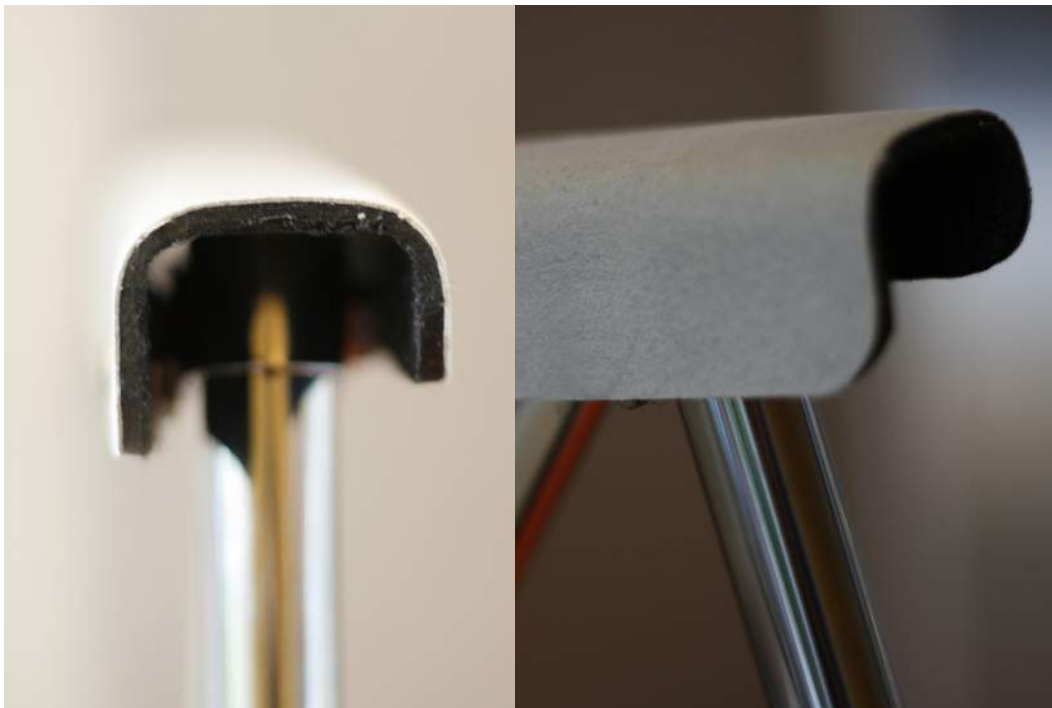

Figure 86. The back angle mechanism is encapsulated within the armrest

each other tightly so that the felt part embraces the frame while still leaving a small part of the frame visible. This allows for the underlying structure, the 'skeleton', to be visually present, enforcing the thorough and steady expression.

The front part of the seat have been kinked down to separate the user's thighs from the steel structure. This allows the user to maintain good blood flow in the legs and contributes to the overall comfort of the chair. The same principle has been used for the backrest,. By separating the users back from the frame of the chair, the backrest becomes more comfortable and inviting to the user.

All of the felt parts of the chair can be draped in any furniture fabric or fitting leather product which makes the chair adaptable, updatable and potentially more interesting.

There is also a possibility to manufacture the seat, backrest and armrest in vacuum formed ABS plastic using the same tooling as for the felt. This expands the areas of use for the

chair as it makes it weather resistant, enabling it to be used outdoors.

9.1.3. The armrest

The armrest is made from the same pressed polyester felt as the seat and backrest. By creating the armrest in the same material, the surfaces that the user come in contact with become visually grouped, resulting in a more visually cohesive expression.

The fact that all the contact surfaces are made in the same material and colour also contrast the "soft" human attributes against the more mechanical and skeleton like expression of the frame structure.

The form design of the armrest is a simple up-side-down U-shape. This form allows for the mechanism controlling the angle of the backrest to be completely visually hidden and more safe as the user can't trap their fingers in it. The rounded shape that is in contact with

the user's hand also contributes to the overall comfort of the chair and allows the user to rest their hand in a grasping position.

9.1.4. The adjustment of the backrest angle

As previously mentioned, the chair features a possibility to adjust the angle of the backrest. This adjustment is available in two steps; the upright state of 95° and a more relaxed state of about 105°. This enables the user to sit more comfortably and also expands the functional use possibilities of the chair.

The backrest angle mechanism is unlocked by gently lifting the front part of the armrests. By applying slight pressure to the backrest (leaning back), the mechanism swivels inside the armrest and the new backrest angle is achieved. (See Figure 87)

9.1.5. The collapsing procedure.

The chair is collapsed by placing one hand around the front part of the seat and the other around the top side of the back. As the two parts are then gently pressed together, the legs and armrest follow the movement and swivel along to rest against each other in the collapsed state. (See Figure 88)

The locking detail work as a support for the frame in the collapsed state. This has been designed to increase the stability of the collapsed package. (See figure 87)

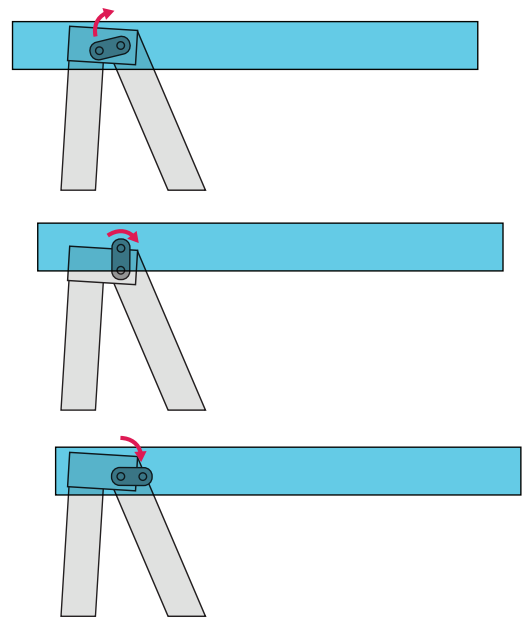

Figure 87. The backrest angle mechanism inside the armrest.

9.2. Cognitive and physical ergonomics

All measurements of the Applåd chair have been designed to fit the 5th-95th percentile of users, resulting in a good availability while at the same time keeping the strong proportions of the form design.

The collapsing procedure has been designed to fit the mental model users have of collapsing chairs in general. This enables users to intuitively collapse the chair in the proper way.



Figure 88. The collapsing procedure



Figure 89. The L-axle

When designing collapsible products, there are always risks that the limbs of the user can be trapped. To ensure that this will not happen, a number of measures have been taken.

By following the mental model the users have of the collapsing procedure, the chair's design enables the users to have their hands in safe positions.

Apart from the collapsing procedure, there is one additional situation where users could potentially risk to trap their fingers; the adjustment of the backrest angle. This risk has been handled putting the hinge on the inside of the armrest, a place where it is not as likely to have one's fingers when adjusting the backrest. The mechanism has also been encapsulated by the armrest, covering it on three sides.

9.2.1. The manufacturing procedure

The frame structure is made up of bent chrome plated $\varnothing 19\text{mm}$ steel tubes. The front and back legs are made up from identical parts which reduces the manufacturing costs. The same principle has been applied to the seat and backrest frame, where they both are identical except an extra bend in the backrest to form the joint between the two parts.

After the bending of the tubes, holes are made for fitting joints. This is preferably done by punching as it is the most cost efficient and simple method. Two details are welded, the piece of steel connecting the

front- to the rear-leg and the axle allowing the seat to revolve around the front leg.

To enable collapsing and adjustment of backrest recline, four details need to be manufactured. The first being the L-shaped axle connecting the seat to the front leg, this is a very simple construction consisting of a $\varnothing 8\text{mm}$ steel bar kinked 90 degrees. (See Figure 89)

The other three are cut and bent out of a 1.5mm steel sheet and forms the hinges connecting the seat to the rear leg and the armrest to the frame.

The hook stopping the rear legs movement backwards is manufactured by welding a bent piece of 2mm sheet steel to a bolt. To facilitate low cost production this solution should be investigated further. (See Figure 90)

The seat and backrest are made of form pressed polyester felt, a sturdy and light material which has been coated with furniture textile to create a soft contact surface for the user to interact with.

The seat and backrest are identical before the cutting procedure. This means that the same tool can be used for the two parts, saving funds in the initial tooling investment process and it saves valuable time in production since only a single tool needs to be mounted in the press.



Figure 90. The locking mechanism

The same idea has been used for the armrests, the two sides feature identical details which can be pressed in the same tool. It may also be possible to press the armrest in the same pressing as the seat/back component. This requires further investigating but would simplify the manufacturing process which saves time and funds.

The chairs frame is assembled using off the shelf M6 & M8 bolts and nuts. For fastening the seat, glue is used as this is a common and well tested method of fastening felt to tubes. This solution is not optimal from a disassembly point of view but will be used for the prototype. An alternative would be to fasten the felt using screws or rivets. Note that this would require extra holes to be punched in the frame and felt details.

9.2.2. Sustainability aspects

The seat

For the seat a needle punched polyester felt is chosen. The polyester used is a synthetic polymer normally referred to as PET (polyethylene terephthalate) (Rosato 2004).

The felt is from the producer Nordifa, and is called "Formfilt 5107 1500(g/m²) 060(colourcode)".

Nordifa was asked which alternatives are available for recycling their material. Their answer was that the felt can be energy recycled through combustion. This is not optimal from an environmental point of view and therefore more sustainable alternatives were investigated and discussed. These alternatives are described below:

Durapulp

Durapulp is a new emerging material developed by nordic pulp-manufacturer Södra. Durapulp is a composite made from specially selected woodpulp and a renewable polymer. The merging of the two result in a material with good strength, hardness and moisture resistance. (Sodra.com, Om-Durapulp, 2011)

The material is bio degradable, but even if it is used one should consider if it is probable that this will be recycled with in the intended biological process.

The material is quite new but has been used in design by Claesson Koivisto Rune in childrens chair Parapu and the w101 lamp.

Polymers

If the seat instead is injection molded or vacuum formed in a plastic material, the need for upholstery is eliminated. This would also make the seat more

weather resistant and open up for outdoor use of the chair. and might also increase the lifespan of the product as some plastics can be more durable.

Felt

As the felt itself isn't wear resistant, lamination with a upholstery polyester textile was chosen. This textile is joined with the felt during the pressing using a sheet polyester with low melting temperature. This means that all three layers that make up the seat are polyester, therefore, if there is a wish to recycle the polyester there is no need of separating the layers.

The common method of attaching felt to a tube frame at Blå Station is to glue. This method is chosen for its simplicity and eliminates use of screws and extra hole punching. As the fastening of the folding chairs seat was discussed one idea was to use screws or rivets. This is a good option to gluing, both when it comes to disassembly but also from a maintenance point of view. By using screws or rivets the seat can be replaced as it is worn out.

The frame

For the final concept chrome plated steel tubing was chosen. Blå Station has historically gone from using chrome to using stainless steel to going back to chrome again. Previously, highly toxic hexavalent chromium was used. As Blå station became aware of this they chose to use stainless steel tubes for their furniture but as the Trivalent Chromium Plating processes were refined and became a less hazardous option the company chose to go back to using chrome.

One thing that has to be considered is that although the chrome plating process is toxic, the surface of the product get a significantly longer lifespan compared to if it had been varnished steel.

The chrome can not be directly recycled as it is very hard to separate from the steel. However, the chromed steel can be melted down together with more chrome to form stainless steel. This is possible as chromium is a key component in stainless steel. The stainless steel can then live on and be melted down and reused without losses again ⁸. This is a recycling process that is widely used today as steel and chro-

mium are valuable metals and the recycling of them is very profitable.

The aluminium alternative

Another possibility is to use aluminium for the legs. This was suggested to Johan Lindau, CEO of Blå, but was discarded as the cost of this would be too high. Aluminium is light which could prove useful if the steel tubes turn out to weigh too much. The aluminium need no additional material as surface coating since it can be anodized to create a protective layer with surface finishes ranging from satin to mirror polished.

Aluminum is a Cradle to Cradle™ material meaning it can be recycled in an endless loop without being downgraded. As the project group visited SAPA, the worlds biggest manufacturer of extruded aluminium, this question was raised. The answer was that, yes, aluminium can be recycled without losing material quality but when looking at reality, the aluminium used by SAPA today is entirely virgin material. This due to the fact that the aluminium produced to date has not yet reached the end of its lifecycle in large enough quantities.

The varnish alternative

One alternative is to paint or varnish the steel frame. This would lead to other visual expressions as the frame would have to feature different colours.

A good thing with painting the frame is that the toxic chromium process can be avoided. However the chair is likely to become more sensible to scratches.

It is also noteworthy that when recycling a painted chair, the paint have to be separated from the steel since it can become a contaminant in the re-melting process.

⁸ Taina Flink (Stena Recycling) Email / Discussion. Fall 2011

10. Discussion

In this chapter, the project group discusses the result of the project. Have the aims and goals been met? Was the right methodology used? What has been difficult and what has been the most rewarding?

10.1. Reaching our goals

When initiating this project. The primary aims were to investigate and create a deep understanding both of the field of collapsible furniture and collapsibility as a general phenomenon. Using literature and methodology properly suited for the task, this goal has been achieved. We feel that we have gained a profound amount of knowledge and skill concerning the mechanic principles behind collapsibility. At the beginning of the project, a lot of warning signs were raised about how much more complicated the development of a piece of furniture becomes when it has the added functionality of collapsibility. We now understand what these people were talking about, seeing how advanced construction and manufacturing of regular furniture is even without the added complexity that collapsibility adds.

We feel truly proud to have pulled off such a project with no previous knowledge of the field.

A great deal of knowledge has also been gained about the most common manufacturing techniques used

in the furniture sector. This knowledge has mainly been gathered through the numerous study visits. The study visits have proven to be much more rewarding than studying literature since they give condensed hands-on information that often comes directly from an expert.

In our case, since we were to build the product ourselves, a quite detailed amount of knowledge was required. We had to be aware of how small radius one can bend a tube with, which order the bends are to be bent, the properties of the felt and so on. Still problems occurred, but solving these were a great learning experience.

We believe that every time one is to design a piece of furniture that is to be produced, this type of knowledge drastically smoothens the development process and leads to more economical manufacturing.

One of the most important aims of the product was that it should feature a so called 'novel' design. What a novel design is can still be discussed but our findings have shown that products that receive a lot of atten-

tion often feature just the right amount of complexity or feature an innovative material, process or form language. We'd like to argue that our chair can be considered novel for a number of reasons. Firstly, it features a seating material that isn't brand new but is not yet widely used within the sector. Our positioning of the chair, in between the most temporary and the more permanent collapsible chairs can also be seen as a novelty.

We also believe that Applåd's form language and use of contrasting materials will be appreciated as innovative and refreshing in the furniture community.

10.2. Methodology

When it comes to the methodology approach used in this project, we are especially happy with the execution of our creative process. Using a large number of established methods as well as a few ones that we've created ourselves, we have managed to come up with a big number of new ideas and processes. Some of these ideas, such as our experiments with leather origami (see Appendix A), have given ideas for the development of other products, both within and outside the furniture field.

Modeling is a method that has been present throughout the development and has proved very valuable for us. It has taken several shapes, simple functional models, more advanced models for setting the proportions and expression of the chair and CAD-models for visualization and calculation of the collapsibility mechanism. All in all modeling, primarily physical, is something often forgotten in this kind of projects and we want to take the opportunity to recommend the method to anyone performing a product development project.

Another part of the project that has proven truly valuable is the use of the core values that we set during the initiation of the project. This has helped us keeping focused on what we wanted the chair to express and a good basis for evaluating the generated concepts.

The most difficult aspect of the academic approach to projects of this type is the decision making and evalu-

ation of concepts and ideas. First of all, concepts regarding collapsibility are very difficult to fully understand since there are so many mechanical properties and functions that must be considered. This means that using matrices and methodology to evaluate the concepts require much more product development prior the evaluation since everything must be fully understood before an informed decision can be made. Even after 8 months of development, we were truly frightened when we had finished assembling the prototype and were to collapse it for the first time. Would it really work the way we thought it would? Had we made the right decisions along the way?

Because of this, most of the big decisions in this project have been made based on our own understanding of the concepts in collaboration with our company supervisor and project examiners professional opinions.

10.3. Amount and level of completion of concepts to present

It is always hard to decide when a concept or model is ready to receive criticism and/or be evaluated. One thing that might have been done prematurely in this project was showing the quite complex looking concept models to Blå Station prematurely. Maybe they should have been further developed before being presented. There was also discussions in the project group about how many concepts to show, in earlier projects an approach with a maximum of three concepts shown to the customer have sometimes been used. This helps the company or tutor presented to get a chance to fully understand all of the concepts. In this project a total of eleven concepts were presented at the first presentation. The reason the amount was so big was simple that the project group could not decide by themselves as the knowledge about manufacturability wasn't sufficient and further advice was needed. In a similar situation in a future project, the project group would recommend to present the big amount of concepts to a tutor or field expert to trim down the amount of concepts before meeting the actual decision maker.

10.4. When to let go - Kill your darlings

When working in a project with a high set goal and a broad design approach, it is often hard to see which ideas are best to work further with and which must be let go of. Some ideas always get favoured because of non-rational reasons that can not be seen at the time. The project group believe these kind of issues can, to some extent, be solved by working in a structured manner. Maybe these 'darlings' can be spotted earlier so that their flaws can be exposed and the concepts seen for what they really are.

A case in the project where this was evident was the development of the Brasse concept. The concept was chosen and a few design proposals were created. Among these were a very similar concept to the one that was finally chosen. But at that time it was discarded since the other concepts, which did not solve the collapsibility as well as this one, was more enticing to work further with. In hindsight, the right way to go had been to choose that first concept at an earlier time. It would have saved a lot of development time that was used to explore other, not as good, options.

10.5. Collapsibility principles

When looking at the market today, the absolute majority of collapsible chairs utilize either hinging or sliding. Our research has shown that there is a reason for this. They feature simple, well tested and traditional constructions which prompts for simple and cost efficient manufacturing.

In this project we have tried to break this pattern and generated a great deal of concepts with other collapsibility principles than the ones stated above. However as the project progressed, one after one dropped off and we ended up with a chair which collapsing follows the more standard solutions found on the market. This was probably because our aim was to produce a production ready chair which could easily be manufactured by Blå Station and its subcontractors.

As the project was initiated, a wish from Johan Lindaus side was for us to investigate side-to-side folding. We had several concepts utilizing this collapsibility principle but it somewhat limited the design of the chair. For example the backrest had to be either a textile or fold in some way. This led to that we could not use a frame for the backrest resulting in a more temporary expression. A side-to-side chair can be at least as stable as a chair utilizing the front-to-back collapsing but the expression of this chair is often more temporary. However there are examples of designers who have succeeded with the combination of side-to-side collapsibility and non-temporary expression, the Stitch chair by Adam Goodrum and X75 chair by Börge Lindau being two of them.

10.6. Designing for production

It has been a real challenge for the project group to design a product that is as ready as possible for manufacturing. In conceptual student projects, there are always some details that have to be left unsolved because of time constraints and project scope. These details always feel like small issues that won't affect the finished product too much but in this project, the group have learned that these small details often lead to make-it-or-break-it issues. Details like this have not been possible to overlook, the group have had to work through them, sometimes solving the problem and sometimes having to realize that the problem is unsolvable and that a few steps must be taken backwards.

This in combination with the big amount of actors and subcontractors that have been involved in the process has led to long lead times. These lead times resulted in that the prototype could not be fully refined and evaluated before the end of the project. This fact in combination with the knowledge gained about which parts take most time can be used by the project group in future project to put effort in the right places at the right times, resulting in a smoother process.

10.7. The key factors for a successful collapsible chair

It is truly hard to specify any general recommendations for this. And the question is if there is an absolute answer to it.

The key factors depend naturally on the context in which the chair is to be used. Is the purpose that the piece is to be used as seating at a festival? Then, simplicity and low cost may be the key factors.

In our case, a premium chair for public environments, novelty is maybe the most important one. The chair has to be seen and stand out through the noise in the market. Reduction is another one, to reduce the design to the very essence of functionality. Often the simplest design is the hardest to achieve.

Cost is also an important aspect, closely related to reduction, which we have given much consideration. By designing for cost efficient production, compromises which otherwise can lead to the furniture never being produced or losing its essence can be avoided.

11. Conclusion & Recommendations

This chapter describes and summarises the results of the master thesis project, and recommends where effort should be put in further refinement.

11.1. Summing things up

The aim of this master thesis project was to design a production ready collapsible chair with a novel expression for Swedish furniture manufacturer Blå Station. The chair was to express a number of values where the perception of non-temporarity was the most prominent one.

Applåds frame creates a light yet stable expression achieved by the gestalt of solid legs. These prominent legs form an expression that helps the chair to be perceived as less temporary than the average collapsible chair.

The vision is that when a person walks into a room and sees the Applåd chair, she will not see a fragile collapsible chair but a steady and trustworthy chair which has the collapsibility added to it as a bonus. A bonus well appreciated by personnel who handle the chairs in their everyday work.

The Applåd chair features a cohesive form language, achieved by repeating form elements throughout the

design. The back and front legs are identical, the seat and back as well. All the bends on the chair have been designed with the same 30mm bends. This repetition of form elements, together with the basic proportions of the chair, create a stringent and clear expression that speaks of premium quality.

To increase the comfort of the chair, the backrest angle can be adjusted in two steps. This function adds to the experienced value of the chair as well as expands the use areas. Imagine sitting at a boring meeting, feeling a bit tired, you can then easily recline the backrest to achieve a more comfortable seating position. Just don't fall asleep!

The chair has also been designed with the core values of refinement and thoroughness in mind. These values are represented through high quality materials and a construction that features a lot of hidden joints and fastening points.

The chair allows for simple manufacturing in a number of ways. The felt parts are identical which means that a lot of funds can be saved on initial tooling. The

back and front leg are also identical, which means that they can be manufactured without having to reconfigure a machine.

To summarize, a novel piece of furniture expressing non-temporality and steadiness has been designed. The construction feels refined and thorough.

At the same time, the project group hopes and believes that the Applåd chair is viable for economical manufacturing.

Novelty has been the guiding star and a goal for Applåd. By taking Brasse, the collapsible chair with maybe the worst reputation of quality and a big stamp of temporality in its forehead, adding innovative materials and design and transforming it into a premium chair expressing quality and non-temporality, a novel design has been achieved.

11.2. Recommendations

Blå Station has a profile as an innovative, premium furniture producer and the designed chair with its novel expression is believed to fit their vision and portfolio.

To expand the possible uses of the Applåd chair we recommend that alternatives for outdoor seating materials are investigated. This could be for example a nylon mesh or vacuum formed plastic which withstands the outdoor environment better.

Also, the weight of the tubes should be optimized by choosing as thin wall thicknesses as possible without risking the frame structure to break or flex too much. An alternative material to the steel tubes would be aluminum, which also has the advantage of not needing to be chrome plated, although this would probably be a more expensive option.

As it comes to the construction, the joint between seat and back should be looked into to validate that the suggested construction (see chapter 8.2) is viable for production.

Finally, or maybe firstly, a complete cost analysis of the production cost of Applåd should be performed, as well as a survey to find how much the customers are prepared to pay for the chair.

12. References

This chapter lists the references used in this report in alphabetical order. The references mainly consist of published articles, books and online resources.

Blå Station's homepage (2011), About Blå http://www.blastation.com/web/About_Bla.aspx. Aquired 28 september 2011.

Blå Station's homepage (2011) About us http://www.blastation.com/web/About_us.aspx Aquired 28 september 2011

Blå Station's homepage (2011) Miljö <http://blastation.se/web/Miljo.aspx> Aquired 15 september 2011

Branton, P. (1969). Behaviour, body mechanics and discomfort. *Ergonomics*, 12(2), 316-327.

DINED (2011) Anthropometric database tool, TU DELFT. Aquired 23 september 2011.

Garner, s. McDonagh-Philp, D. (2002) Problem Interpretation and Resolution via Visual Stimuli: The Use of 'Mood Boards' in Design Education. *Journal of Art & Design Education* Volume 20, Issue 1.

Gentner, D. Stevens, A L. (1983) *Mental models*. Hillsdale, NJ: L. Erlbaum.

Hekkert, Paul (2006) Design aesthetics: principles of pleasure in design. *Psychology Science*, Volume 48, 2006 (2), p. 157 - 172

Johannesson H, Persson JG & Pettersson D (2004) *Produktutveckling – Effektiva metoder för konstruktion och design*. Stockholm: Liber.

Karjalainen, Toni-Matti & Snelders, Dirk (2010). Designing Visual Recognition for the Brand. *Journal of Product Innovation Management*, 27 (1). 6-22.

Karjalainen, Toni-Matti (2009). Visual Brand Recognition. Lecture, Chalmers, Visual Brand Identity course 2009.

Karjalainen, Toni-Matti (2007). It Looks Like a Toyota: Educational Approaches to Designing for Visual Brand Recognition. *International Journal of Design*, 1(1).

Karlsson, M., 2007. Lyssna till kundens röst. Course compendium. Chalmers University of Technology, Gothenburg. The Institution for Product and Production Development, Department of Design.

Lefteri, C. (2007). Making It: Manufacturing Techniques for Product Design. London: Laurence King.

Lohmann, Birgit (2003) The Illustrated History of Folding Chairs, compiled by, (a thesis publication, July 1988, revised in June 2003) © designboom, accessed from <http://www.designboom.com/eng/education/foldingchair.html>

Monö, Rune (1997) Design for Product Understanding. Stockholm: Liber.

Rosato, Dominick V.; Rosato, Donald V.; Rosato, Matthew V. (2004), Plastic product material and process selection handbook, Elsevier, p. 85, ISBN 9781856174312

Södras homepage (2011) Om-Durapulp, <http://www.sodra.com/sv/Forskning/Forskning-om-fiber-och-massa/Om-Durapulp> Acquired 20 september 2011

UPA - Usability Professionals' Association. (2005-2010) Usability Body Of Knowledge. Retrieved September 14, 2011, from <http://www.usabilitybok.org/methods/p866>

Warell, A. (2006). "Identity Recognition in Product Design: An Approach for Design Management". Proceedings of the 13th International Product Development Management Conference. Milan: Politecnico di Milano. June 11-13 2006.

Zacharakis, Andrew. Minniti, Maria. Spinelli, Stephen, P. Rice, Mark. G. Habbershon, Timothy. (2006) Entrepreneurship: The Engine of Growth, Volume 1. Prager.

13. Appendices

This chapter contains all the information and data that is not directly featured in the report.

Appendix A. Miura Leather	98	Interview with Johan Lindau	108
Appendix B. Market positioning ipad application	100	Appendix J. Morphological Innovative Spur Sentences	109
Appendix C. Process based ideation template	101	Appendix K. Prototyping	110
Appendix D. Inspiration board	102	Appendix L. Additional product photos	112
Appendix E. Material starting points for armrest	103		
Appendix F. Models and Mockups	104		
Appendix G. Supporting Pugh evaluation matrix	106		
Appendix H. Design Format Analysis	107		
Appendix I.			

Appendix A. Miura Leather

A field that was studied extensively in the ideation phase was the field of origami. Since origami has been around for a very long time, there are many well thought out patterns and creasing-styles that can be utilized as inspiration when designing collapsibles. One style that was deemed to have potential is the Miura-fold. It has been used for many applications, one being space saving solar panels for NASA satellites.

The project group experimented with folding the Miura pattern in different sizes and material to analyse its properties. It was clearly and interesting technique that could be used in a chair seat or backrest as it in its collapsed state greatly reduces the length in one direction while the other direction only reduces a small portion of the original size. One problem that was found was that the Miura pattern took a lot of time to complete, meaning that it would not be viable for cheap and simple manufacturing. An idea sprung from this; would it be possible to press the pattern in a mould?

A small mould was created in a wood workshop and initial pressing attempts were conducted using paper and different textiles as raw material. As these materials were not very good at keeping the pressed structure intact, other alternatives were looking into. One of the best candidates turned out to be raw cow hide leather. It had to be sunk into hot water to become more ductile but when left to dry in the mold it turned out to keep the pressed creases in a very good way.

As this seat/backrest solution could function with many different frame collapsing techniques, as long as they reduce the size in one horizontal direction, a decision was made to put its development on hold until the frames had been developed further.





Appendix B. Market positioning ipad application

The application was created to gather brand positioning data from users. The users were asked to sort different brand according to a number of values. The values were among others: Quality, Sustainable, Innovative, Curious, Reliable and Luxurious.

When the user was done sorting, a snapshot was saved for the data analysis phase.



Appendix C. Process based idea- tion template

PROCESS / FORM POSSIBILITY BASED IDEATION				MATERIAL
PROCESS / PROPERTIES	PROCESS / PROPERTIES	PROCESS / PROPERTIES	PROCESS / PROPERTIES	PROCESS / PROPERTIES
PROCESS / PROPERTIES	PROCESS / PROPERTIES	PROCESS / PROPERTIES	PROCESS / PROPERTIES	PROCESS / PROPERTIES
PROCESS / PROPERTIES	PROCESS / PROPERTIES	PROCESS / PROPERTIES	PROCESS / PROPERTIES	PROCESS / PROPERTIES

Appendix D. Inspiration board

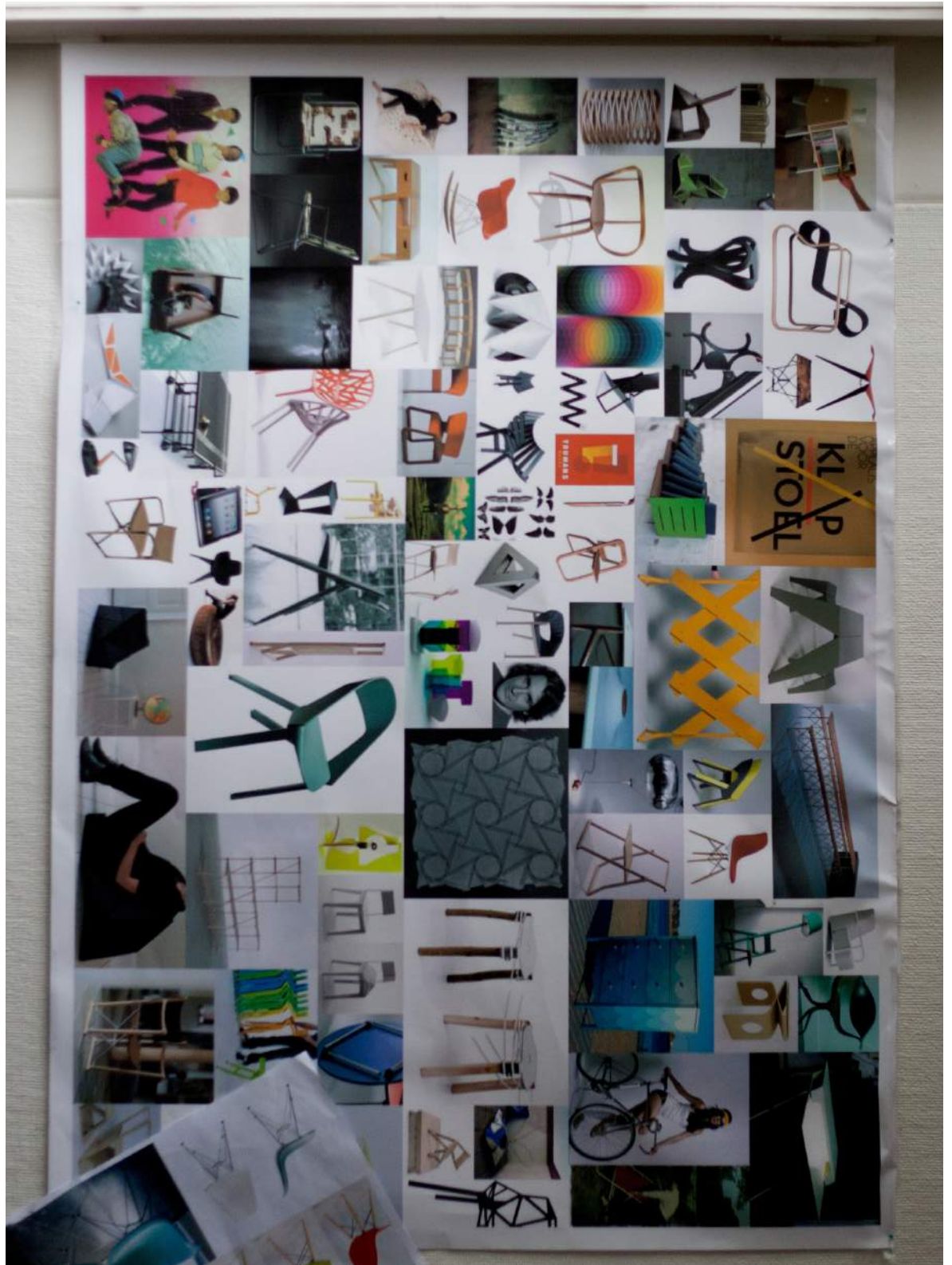

Appendix E.

Material starting points for armrest

Sheet materials

Sheet metal

- Bending
- Milling

Aluminium

- Bending
- Milling
- Extruding

Leather

- Wrapping
- Stiffening

Textile

- Felt
- Felt with textile

Solid materials

Wood

- Milling
- Bending

Metals

- Milling
- Moulding

Foams

- Milling
- Moulding

Plastics

- Milling
- Vaccum forming
- Moulding

Tubes

Steel tubes

- Bending
- Milling
- Tapering

Aluminum tubes

- Bending
- Milling
- Tapering

Appendix F. Models and Mockups

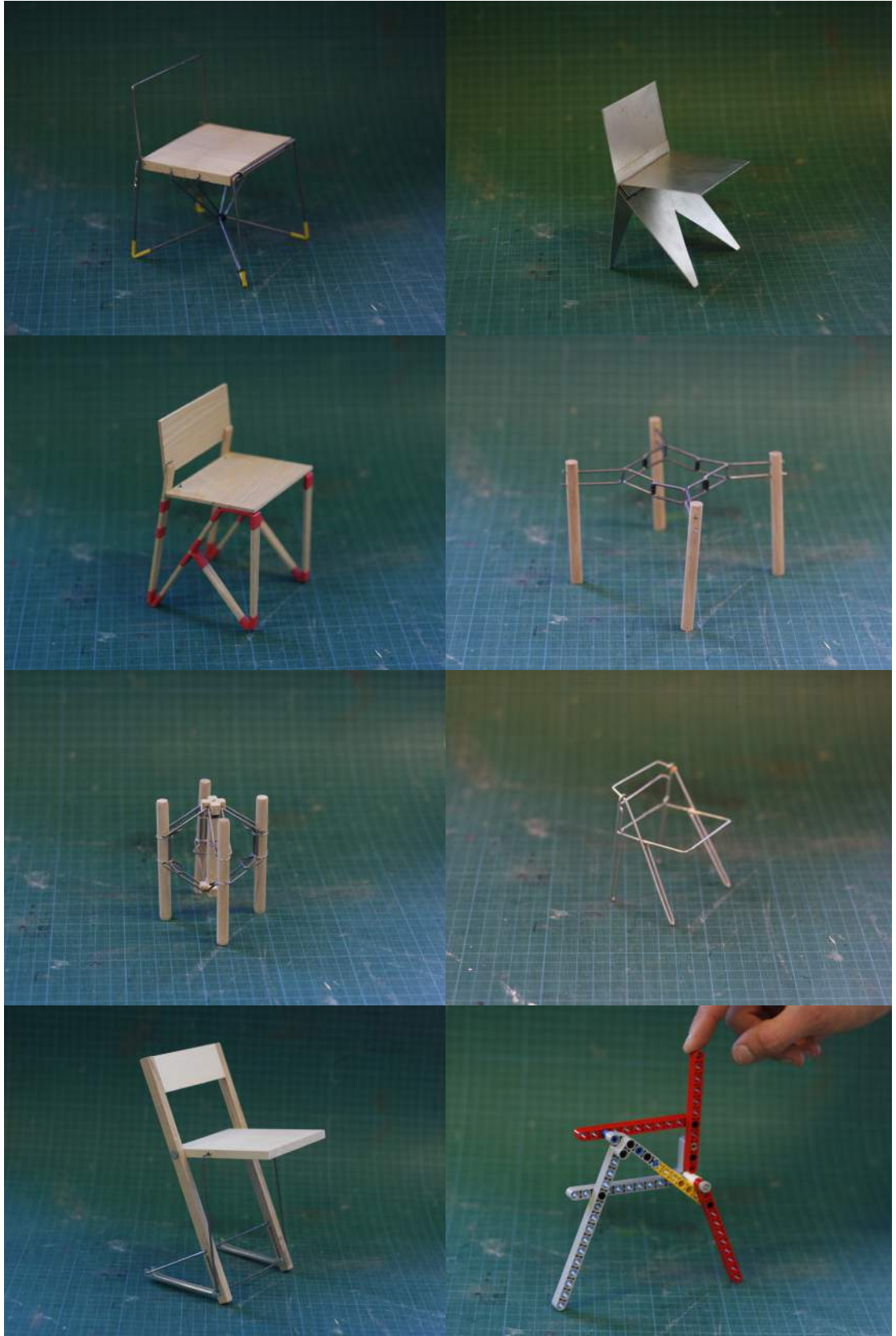



Appendix G. Supporting Pugh evaluation matrix

VALUES WEIGHT	INNOVATIVE 3	SIMPLE (CHEAP) 4	STABLE EXPRESSION 3	SAFETY 5	FLAT FOLDING 4	STACKING 3	SIMPLE UNFOLDING/FOLDING 4	SUM
UNILEG	1	-1	1	-1	0	-1	-1	-10
SPLIT	1	1	1	1	-1	0	1	15
SIMPLEX	1	1	-1	0	1	0	1	12

Appendix I.

Interview with Johan Lindau

The purpose of the interview was to gain a better understanding of the purchase procedure, guidelines for the development of the chair and to confirm that the approach of the project is in line with how BLÅ Station work.

The purchase procedure

In order to design a product one must have knowledge of who the buyer and end user is. The purchase procedure at BLÅ Station is as follows;

“We market ourselves through visits to architects and other clients. As the architect has made up his mind in regard to which furniture that suite the environment, a specification is written of which furniture is - recommended. However there is a paragraph often used which claims that the chosen furniture can be replaced with equivalent furniture. This is a problem since equivalent can mean so many things, the furniture in the specification can be replaced by other furniture with equivalent cost, colour, looks etc.”

This leads to a lot of extra work for BLÅ Station in order to protect their order.

Thus the main customer group for BLÅ Station is architects and secondly interior design companies, such as European Furniture Group and Kinnarps. The end user has little to say when it comes to which furniture that is to be bought. With all right says Johan, they don't know what they want! “We've tried to market us to the home environments but with little success.”

The ultimate chair

To better understand Johans vision of the folding chair he was asked to describe what the ultimate folding chair looks like folded and unfolded. His answer was short and concise; “Good looking and good looking”. He developed further by saying;

“Folding chairs should be comfortable but doesn't have to be super ergonomic, they are made for shorter periods of sitting down. They should take up as little space as possible but the thicker they are, the higher are the demands on comfort. There can be no risk of squashing ones fingers. It should be intuitive and look stable. Big folding movements are better than small. Integrate as much of the functionality into every piece of the chair. Use as few components as possible.”

When asked if he had any suggestions of folding techniques that should be investigated Johan answered that the side-to-side folding, as in a classic directors chairs, is a folding technique rarely used nowadays. Most folding chairs uses the front-to-back folding and by using side-to-side folding a blank space on the market can be filled.

The wow-effect's relevance was discussed and Johan was of the opinion that the wow-effect can be relevant as long as it doesn't conflict with the purpose and clarity of the function of the product.

“I see furniture as tools. It is the purpose of the furniture that needs to be the focus of the functional development. The essence of design is to communicate a clear message!”

The approach

Johan found the approach of our project, with as many study visits to the manufacturing industries as possible, to be a good idea. When working for BLÅ Station the designers Stefan Borselius and Fredrik Mattson have used this technique, sometimes on their own and sometimes accompanied by Johan. He called the concept Eriksgata (King's tour) after the journey the medieval Swedish kings to be had to do around the country as they were to be crowned.

Finally Johan sums thing up by saying that the goal of the project today, to design a foldable chair, may change during the process and one might end up with something else, a table or a sofa. As long as the idea is good this doesn't matter!

Appendix J.

Morphological Innovative

Spur Sentences

LOOK / EXPRESSION	TECHNIQUE	METHOD	MATERIAL
<p>Interesting tilted look</p> <p>Open ended pipe create a light look</p> <p>Interestingly subtle</p> <p>Rhin, high placed arm chair seat</p> <p>Wow-factor through folding</p> <p>Airy and spacious due to extension</p> <p>Visually separated seat through colour</p> <p>Looks compressible due to the spaces</p> <p>Not carving into the leg gives the leg a un-fixed look</p> <p>Playful and inviting by tilted neutral position and simplicity.</p> <p>Simple look -sleek legs with even thickness and two-axis joints</p> <p>A well-worked underside adds quality value</p> <p>Reduce compact look by adding gaps</p> <p>Floating (actual)</p> <p>Coherence through repetition</p> <p>Animal slender</p> <p>Elastic</p> <p>Falsely weak and light</p> <p>Traditional</p> <p>Changes between stationery and in use</p> <p>Cute</p> <p>Faceted</p> <p>Well chosen contrasting Materials</p> <p>Precision material meetings creates interesting contrast</p> <p>Leg looking like it stretched the surface its fastned to creates organic look.</p> <p>Playful</p> <p>Uniform look due to single color and material + no visible parting lines</p> <p>Industrial look</p> <p>Flowing lines create a sleek instrumental look</p> <p>Using negative space to build shape</p> <p>Sleek look through thin waist</p>	<p>M-folding technique with angular joints</p> <p>Weld/glue free puzzle assembly</p> <p>Wavy fold patterned wood</p> <p>Individually customisable screw legs</p> <p>Objects draped in elastic textile</p> <p>Self standing when folded</p> <p>Self stabilising C-shaped legs</p> <p>Very thin bearing legs</p> <p>Origami flower-folding</p> <p>Split seat</p> <p>Offset joint creates slim folding</p> <p>Shape-integrated function</p> <p>Legs meet halfway down, the fastening of the legs look like they can rotate. Could be effective collapsible.</p> <p>Two-axis joints</p> <p>Color mixing</p> <p>Connecting multiple chairs with piece of similar style</p> <p>Using multiple identical elements for the base shape</p> <p>Elasticity in the structure itself</p> <p>Metal thread structure with unseen reinforcements</p> <p>Lattice structure, made of bars with integrated nodes</p> <p>Identical seat & backrest</p> <p>Thick wooden pieces</p> <p>Variable softness throughout shapes after body</p> <p>Unexpected leg direction</p> <p>Three legs</p> <p>Suitcase-like in folded state</p> <p>Many thin bars create strong lattice</p> <p>Loose/hanging seat part held up by frame structure</p> <p>Stretched out plywood with built in tension creates flexible seating</p> <p>Single joint for legs and seat</p> <p>Combination of beams and ropes which take up the tensile strength</p> <p>Designed for dynamic connection of a row of chairs</p> <p>Backrest made from flexible material supported by spring steel.</p> <p>Enabling connectivity through shape</p> <p>Origami inspired collapsing technique</p> <p>Built in flexibility through origami tech</p> <p>Scissor like folding extendability</p> <p>Vertical beams strengthened by diagonal struts</p> <p>Super compact</p> <p>Side to side folding</p> <p>Rocking feet</p> <p>Everything made from the same block</p> <p>Seat attached to either protruding end of X</p> <p>Adjustable seating angle due to pins.</p> <p>Leg, seat and back all made from a single kinked sheet</p>	<p>Steel pressing</p> <p>Unknown smooth surfacing method for aluminium profiles</p> <p>Sandwiching layers</p> <p>Metal sheet blowing</p> <p>Rolled veneer pipes</p> <p>PET blow-moulding</p> <p>Textile hinges</p> <p>Variable leg construction</p> <p>Thin sticks of laminated wood in a wave-pattern glued together by the crests</p> <p>One extra leg added, longer than the rest.</p> <p>Metal skeleton dressed with i.e. wood.</p> <p>Helium filled thin metal foil</p> <p>Woven textile as seat and/or backrest</p> <p>Single soft structure</p> <p>90°+ twisted laminated wood</p> <p>Cut from a single planar sheet</p> <p>Folded from a single planar sheet</p> <p>Cut from planar sheet then bent into shape</p> <p>Bent metal with cut-seams</p>	<p>Steel plates</p> <p>PET + GF</p> <p>DuraPulp</p> <p>Wooden legs combined with lacquered seat.</p> <p>Transparent coloured PMMA.</p> <p>Honeycomb paper</p> <p>Metal thread structure</p> <p>Ropes</p> <p>Seating docver made from pressed foam material.</p>

Appendix K. Prototyping

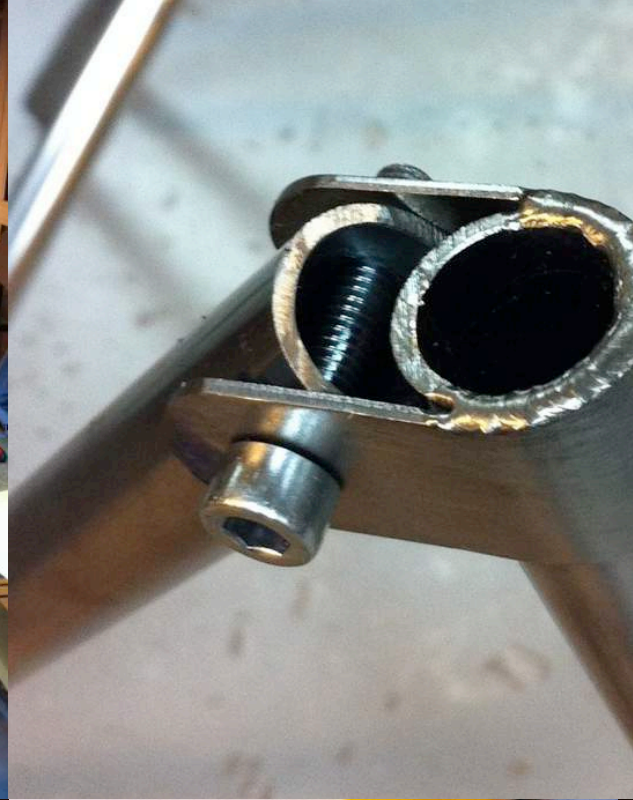



Appendix L.
Additional product
photos



